

Scoping Document

January 31, 2008

John P. Fitzgerald, Senior Management Economic Development
Boston Redevelopment Authority
Boston City Hall, 9th Floor
Boston, MA 02201

RE: Boston College Amendment to the IMP Brighton Campus

Dear John:

Thank you for the opportunity to comment on the Institutional Master Plan Notification Form/Project Notification Form (IMP 10 year plan).

The main components of the physical development of the Brighton campus include: the main components of the IMP 10 year plan include: four new academic buildings, a Recreation Center, a new student housing facility, new and replacement on-campus student housing, and renovations of existing

The Boston Transportation Department (BTD) has reviewed the Institutional Master Plan Notification Form/Project Notification Form (IMP 10 year plan) for Boston College's proposed IMP 10 year plan and has the following comments/concerns:

TRIP GENERATION

- Page 6-11 states that there could be some limited trip generation associated with the retail portions of the projects located on Commonwealth Avenue. Clarification as to what type of retail is being proposed and where along with mitigation measures, analysis and results of the analysis.
- The proponent should be using BT's mode share XX for this area.

TRANSIT

The purpose of evaluating the existing routes, ridership, and hours of operation of the MBTA service and Boston College shuttle is to identify recommendations in service and be able to develop recommendations to improve transit services and ridership on the vicinity of Boston College. I would like to see recommendations on this issue. I would like to see a study about consolidating the MBTA service with the Boston College Shuttle service?

- would residents in the area be able to use the shuttle service?

PARKING

What are the current parking rates at Boston College and how do they compare to other colleges in the area? What are the new fees and what is the parking fee program for next 10 years? Are students offered a discount?

- There are currently 700 parking spaces on the Brighton Campus proposing on building a parking garage for 500 new spaces and displacing 425 spaces. How soon would the 425 spaces be displaced? Immediately or over time?

How soon would the 425 spaces be displaced? Immediately or over time? How soon would the 425 spaces be displaced? Immediately or over time? regulatory parking such as: Resident Parking.

TRANSPORTATION INFRASTRUCTURE CHANGES

- The propose relocation of St. Thomas More Road involves for all of the proposed options.
- The proponent proposes to enter the Brighton Campus via Lake Street. There are currently 3 entrances via Lake Street. The community has expressed concern about going to be used by whom, as well as, submitting a proposed traffic analysis.
- RTD would like to see the proponent tighten up St. Thomas More Road, Fr. Herlihy Drive and Commonwealth Avenue Intersection.
- The proponent should clarify any right of way issues that are associated with the relocation of St. Thomas More Road.
- There is currently an entrance to the Brighton Campus form Foster Street. What will the overall use of the entrance be?

MBTA Boston College Green Line Station

Traffic management of the intersections of St. Thomas More Road, Commonwealth Ave. as well as the surrounding community.

PEDESTRIAN/BIKE PATHS

- The proponent should show in detail how the continuous pedestrian corridor is going to

who would use it and will it be handicapped accessible?

- BTD would like to see a bicycle lane installed on Beacon Street between Chestnut Hill

BTD looks forward in working with Boston College and the BRA in developing a traffic management plan that will help minimize traffic impacts and improve transportation conditions in the area.

In conclusion I have attached BTD's standard Scope of Work. BTD looks forward in working with Boston College to identify specific components of the Scope of Work that need to be done. BTD looks forward in working with Harvard University in expediting the submittal of a Draft Project Impact Report (DPIR) and Preliminary Adequacy Determination (PAD).

Sincerely,

William H. Conroy IV,
Senior Planner

- Cc: Vineet Gupta, Director of Policy and Planning
- John DeBenedictis, Director of Engineering

BOSTON TRANSPORTATION DEPARTMENT
TRANSPORTATION ACCESS PLAN GUIDELINES

And
SCOPE OF WORK

Boston is a dense city, with high levels of vehicular congestion, pedestrian traffic, and parking impacts that require analysis, review, and mitigation. Through the city's development review process, the Boston Transportation Department (BTD) works with development teams (the project proponent) to ensure that they thoroughly evaluate the transportation impacts associated with the proposed project, propose and analyze ways to mitigate these transportation impacts, and implement appropriate mitigation measures.

The project proponent is responsible for assessing and mitigating the short-term and long-term impacts of the proposed project, submitting the following:

1. Transportation Access Plan. The Transportation Access Plan shall fully describe all transportation-related issues surrounding the proposed project. It should include the following principal components:
 - Description of Existing Transportation Conditions. A summary of existing traffic, transit, bicycle, and parking conditions.
 - Evaluation of the Proposed Project's Long-Term Impacts. A description of the proposed project and a detailed analysis of the project's long-term impacts on traffic, public transit, pedestrian, bicycle, and parking conditions.
 - Mitigation of the Project's Long-Term Transportation Impacts. Identification of appropriate measures to mitigate project impacts, including physical and operational improvements, travel demand management (TDM), and long-term project impact monitoring.
 - Description of the Project's Short-Term Construction Impacts and Proposed Mitigation. General overview of the project's construction impacts, construction schedule and phasing, and measures to mitigate the short-term impacts. This is a summary of the more detailed Construction Management Plan (CMP) to be submitted to BTD under separate cover.

The Access Plan typically comprises the transportation component(s) of the proposed project's Draft Project Impact Report (DPIR) or Draft Final Project Impact Report (FPDR), or a separate document. In any case, the Access Plan ensures the scope of work set forth below. The analysis and reporting guidelines below are designed to be general enough that they will apply to most or all major development projects, but also detailed enough to ensure adequate information and equitable review of all projects. The guidelines shall be followed as closely as possible. If the project proponent believes that certain provisions are not applicable to the development in question, the proponent shall seek BTD approval to forego those provisions.

2. Construction Management Plan. The Construction Management Plan (CMP) shall include a detailed proposal for the proposed project's construction: schedule, phasing, and occupancy of the public right-of-way, access and delivery requirements, transportation impacts, and mitigation. The proponent shall submit the CMP to RTD, under separate cover from the Access Plan. The project's general contractor typically prepares the CMP. Guidelines for preparation of the CMP are available from RTD. The CMP shall be prepared in accordance with the requirements of a Building Permit from the City of Boston's Inspectional Services Department (ISD).

3. Transportation Access Plan Agreement. The Transportation Access Plan Agreement (TAPA) is a formal agreement that formalizes the findings of the Access Plan, the mitigation commitments, elements of the project's design, and the responsibilities of the developer and RTD. The TAPA shall include, but not be limited to, the proposed project's design, and assessment of mitigation requirements, it must be executed only after the project's design through the City of Boston's Public Improvements Commissioner (PIC) and assessment of mitigation requirements, it must be executed only after the project's design through the City of Boston's Public Improvements Commissioner (PIC) have been completed. However, the TAPA must be executed prior to the project's design through the City of Boston's Public Improvements Commissioner (PIC) responsibility to complete the TAPA, and approval of the document commitments for the project, and to get RTD and approval of the document

STUDY AREA

The Access Plan shall consist of a thorough analysis of the proposed project's transportation impacts throughout the relevant study area. The study area shall comprise the project's way and important transportation

- a. Commonwealth Avenue @ Lake Street/St. Thomas More Road
- b. Commonwealth Avenue @ Foster Street
- c. Commonwealth Avenue @ Chestnut Hill Ave.
- d. Commonwealth Avenue @ Old Colony
- e. Commonwealth Avenue @ South Street
- f. Commonwealth Avenue @ Brighton Campus Driveway
- g. Proposed St. Thomas Road @ Commonwealth Avenue
- h. Beacon Street @ St. Thomas Moore Road/Chestnut Hill Driveway
- i. St. Thomas Moore Road @ Chestnut Hill Driveway
- j. Father Henry Way @ St. Thomas Moore @ St. Thomas Moore Road
- k. Beacon Street @ College Road/Hanmoria Street
- l. Beacon Street @ Chestnut Hill Avenue
- m. Beacon Street @ Reservoir Avenue
- n. Lake Street @ Washington Street
- o. Lake Street/Kenrick Street/Glenmont Road
- p. Foster Street @ Rogers Park Avenue
- q. Foster Street Brighton Campus Drive
- r. Foster Street @ Washington Street
- s. Washington Street Chestnut Hill Avenue/Market Street

...and planning studies that would affect the study area, and to integrate these into the transportation analysis, as appropriate.

DEFINITION OF TASKS

Task 1. Description of Existing Transportation Conditions

within the study area. It shall focus on the issues listed below, and shall identify any existing problems or deficiencies in the transportation system. The Existing Conditions analysis will form the basis for projecting future conditions, and enable comprehensive assessment of the proposed project's transportation impacts.

1.1 Project Site Conditions. Describe general conditions in the vicinity of the project site, including:

Existing land use, including existing site square footage, building square footage, number of employees or residents, zoning provisions, and other applicable information

- Physical condition of the site, existing access and egress
- Major streets and intersections in the vicinity of the site
- On-street regulations

Include a survey of existing conditions:

1.2 Traffic. The Access Plan shall include traffic volume counts at the study area intersections for weekday morning and evening peak and evening peak periods under existing conditions.

Depending upon the nature of the proposed project, a traffic analysis for additional situations or conditions, such as the Saturday afternoon peak

study area intersections. Analyses shall reflect realistic peak period characteristics, stops, pick-up / drop-off, usable lanes, grade, and percentage of heavy vehicles. Appropriate traffic models will be discussed below.

1.3 Parking. The Access Plan shall summarize the parking supply within 1/4 mile of the project site. The parking inventory shall focus on publicly available spaces, but shall

The parking inventory shall include:

- a. Location (block face for on-street spaces, facility for off-street spaces). Include a graphic representation of the parking supply locations with respect to the project.
- b. Type of Space
 - On-street (metered, resident parking, unregulated, etc.)
 - Type: resident, employee, commercially-available, customer, etc.)
- c. Parking Fees, by Type of Space
- d. Percentage Utilization During Parking Peak (assume 12 noon)

This inventory can be supplemented with data from published sources such as the

If there is currently parking associated with the project site, the Access Plan shall summarize the parking use and management. The description of existing on-site parking use shall include number of spaces, occupancy, and utilization of spaces by user type, hour of day, and day of week.

1.4 Transit. The Access Plan shall describe the study area's mass transit system:

a. Transit Supply

- Massachusetts Bay Transportation Authority (MBTA) services, proximity to site
Service (mode of transit, line, closest station stop)
 - Service characteristics (frequency, timing, peak periods, connections)
 - Physical characteristics (station conditions, rolling stock)
 - Private transit services (summarize characteristics above)
 - Other transit and high-occupancy vehicle (HOV) services

b. System Utilization

Capacity by line during peak periods

1.5 Pedestrians. The Access Plan shall include a description of pedestrian conditions on sidewalks and intersections adjacent to the site, including major pedestrian routes and desire lines in and around the site, volumes of pedestrians on these routes, and the conditions of these corridors, including any deficiencies or barriers.

The pedestrian level of service shall be calculated at the following intersection crossings and driveway crossings:

- a. Commonwealth Avenue @ Lake Street/St. Thomas More Road
- b. Commonwealth Avenue @ Foster Street
- c. Commonwealth Avenue @ Chestnut Hill Ave.
- d. Commonwealth Avenue @ Old Colony
- e. Commonwealth Avenue @ South Street
- f. Commonwealth Avenue @ Brighton Avenue @ Brighton Campus Driveway
- g. Proposed St. Thomas Road @ Commonwealth Avenue
- h. Beacon Street @ St. Thomas Moore Road/Chestnut Hill Driveway
- i. St. Thomas Moore Road @ Chestnut Hill Driveway
- j. Father Herilhy Way @ St. Thomas Moore Road
- k. Beacon Street @ College Road/Hammond Street
- l. Beacon Street @ Chestnut Hill Avenue
- m. Beacon Street @ Reservoir Avenue
- n. Lake Street @ Washington Street
- o. Lake Street/Kenrick Street/Glenmont Road
- p. Foster Street @ Rogers Park Avenue
- q. Foster Street Brighton Campus Drive
- r. Foster Street @ Washington Street
- s. Washington Street/Chestnut Hill Avenue/Market Street

Describe pedestrian accommodation at signalized intersections in the study area (i.e. exclusive vs. concurrent, crossing time provided).

Identify existing and proposed bicycle racks, primary bicycle routes, and the current subsidy and location of any existing bicycle racks on or adjacent to the project site. On a day with good weather (record date and weather conditions), survey bicycle rack utilization by location. Document survey in record of bicycles in locations without bicycle racks. Include bicycle volume counts at the following intersections and bike routes.

a. Commonwealth Avenue @ Lake Street/St. Thomas More Road

b. Commonwealth Avenue @ Foster Street

c. Commonwealth Avenue @ Old Colony

d. Commonwealth Avenue @ South Street

e. Commonwealth Avenue @ Brighton Campus Driveway

f. Proposed St. Thomas Road @ Commonwealth Avenue

g. Beacon Street @ St. Thomas Moore Road/Chestnut Hill Driveway

h. St. Thomas Moore Road @ Chestnut Hill Driveway

i. Father Herlihy Way @ St. Thomas Moore Road

j. Beacon Street @ College Avenue/Hammond Street

k. Beacon Street @ Chestnut Hill Avenue

l. Beacon Street @ Reservoir Avenue

m. Lake Street @ Washington Street

n. Lake Street/Kennick Street/Clement Road

o. Foster Street @ Rogers Park Avenue

p. Foster Street Brighton Campus Drive

q. Foster Street @ Washington Street

r. Washington Street/ Chestnut Hill Avenue/Market Street

1.7 Off-Street Loading Guidelines. Harvard University's 'Off-Street Loading Guidelines', a copy of which is attached for reference. The guidelines can also be accessed from the City of Boston website at http://www.cityofboston.gov/transportation/off_street.asp. Adherence to the 'Off-Street Loading Guidelines' will help to minimize adverse impacts on residents.

Task 2. Evaluation of Proposed Project's Long-Term Transportation Impacts

The primary purpose of the Access Plan is the evaluation of the proposed project's long-term transportation impacts. The Access Plan must address, in detail, for all the transportation modes and aspects that will be affected, including traffic, parking, public transit, pedestrians, bicycles, and service and loading. These impacts must be compared to the appropriate baseline condition, the Future No-Build Condition. The following are the primary issues, modes, and conditions that must be analyzed.

2.1. Project Description. The Access Plan shall include a summary of the key project

- Project name and street address
- Study area, including critical intersections
- Anticipated construction start and completion dates
- Relevant zoning regulations with respect to use, parking and other characteristics
- Required permits, variances, and licenses
- Site area
- Project's gross square footage and floor-area ratio (FAR)
- Gross square footage by use
- Other relevant variables (e.g. number of dwelling units, number of hotel rooms, number of employees)

2.2. Trip Generation Analysis. The Access Plan shall include a trip and vehicle trip generation analysis for the proposed uses of the site. This analysis shall include:

- c. Person Trip Generation. The Access Plan shall summarize the proposed project's person-trip generation for daily, AM peak, and PM peak trips. For certain uses, person-trips shall also be calculated for other time periods, such as Saturday

The person-trip calculations shall be based on appropriate trip generation rates, typically the Institute of Transportation Engineers (ITE) *Trip Generation Manual*, 6th Edition. The ITE manual includes comprehensive vehicle-trip generation rates based on land use and building type in the United States. Because Boston benefits from an excellent public transit system, ITE vehicle-trip generation rates are not directly applicable to resulting vehicle trips. ITE rates shall be used to generate total person-trips by correcting for vehicle occupancy rate (VOR). Trip generation rates shall be based on the most common ITE trip generation rates and corrected for VOR. The applicant shall use these trip generation rates wherever possible. Where necessary, these trip generation rates may be supplemented by data or information from other sources (subject to DTD requirement and/or approval). The person-trip generation analysis shall be summarized in a clear table, in the body of the Access Plan, including all of the following information:

- Land use type
- Vehicle-occupancy rate (VOR) assumption, by land use type (for translation of vehicle-trip rates to person-trip rates)
- Daily person-trip generation (by land use and overall)
 - Daily person-trip generation rate (per 1,000 square feet, or per unit)
 - Resulting daily person-trip ends
- AM peak hour person-trip generation (by land use and overall)
 - AM peak hour person-trip generation rate

AM peak hour person-trips, exiting

- PM peak hour person-trip generation rate
- PM peak hour person-trips, entering
- PM peak hour person-trips, exiting
- Source for trip generation rates

b. Mode Split and Vehicle Occupancy (Vehicle Occupancy Rate). Person-trips shall be apportioned among the various principal modes (automobile, public transit, walking, bicycling, etc.) according to an appropriate mode split. The mode split shall be presented as percentages of automobile, public transit, and walk / bicycle travel. The Transportation Planning Staff (CTPS) has compiled appropriate mode split assumptions for various sections of Boston, according to trip type. Zone 10 should be used to determine these mode splits, along with VOR for automobile trips, are included in Appendix viii. The mode split calculation shall be based upon these assumptions. If the proponent wishes to adjust these mode splits based upon specific circumstances, the proponent shall justify such adjustments by appropriate mitigation commitments (e.g. enhanced travel demand management to justify a higher public transit mode share). The mode split and VOR assumptions in Appendix v. The Access Plan shall include a clear, easily understood table that summarizes the mode splits and the resulting trip generation rates by trip purpose, and by mode.

c. Trip Distribution. The trip distribution shall identify the directional split (i.e. north, south, west) of person-trips and vehicle-trips for the specific location and trip types of areas of Boston is included in Appendix xx. The trip distribution is allocated by individual mode, and should be applied to the resulting trip totals by mode. The Access Plan shall use this information for trip distribution assumptions, unless the CTPD recommends or approves other trip distribution assumptions.

d. Trip Assignment. The distributed trips shall be assigned to the appropriate means of travel (e.g. highway, surface streets, surface intersections, etc.) based upon an off-site parking stub. Trips shall be assigned appropriately to these locations. Drop-off/pick-up locations shall be both entering and exiting the site access, and entering or exiting an off-site parking area.

Attached appendices include the base assumptions that the project proponent shall use for trip generation rates, mode splits, and distribution, and vehicle occupancy rate for specified areas of Boston. The proponent may propose alternative assumptions, such as proximity to public transit (not relevant for such special circumstances warrant, the proponent may propose alternative assumptions, which are

project is expected to be complete, occupied and operating. The effects of the demonstrated in comparison to projected transportation conditions during the horizon year without the effects of the proposed project.

- The horizon year shall be five years in the future, unless specific circumstances require that a different time frame be used.
- The Future No-Build Condition shall be based on the Existing Conditions plus the assessment with the addition of development and infrastructure projects that have been proposed and are expected to be complete and operational by the horizon year (per BTD and BPA instructions).

The Future No-Build Condition traffic, transit, and pedestrian volumes shall also include a background growth rate of $r = 1.72\%$ per year (depending upon local conditions) added to existing traffic volume counts, transit ridership, and pedestrian counts, unless otherwise specified by BTD.

2.4 Future Build Condition: The central component of the Access Plan is the assessment of the proposed project's long term impacts. This shall include evaluations of the project's effects on all transportation modes and aspects, throughout the study area.

a. Traffic Impacts.

i) Traffic Volumes: The traffic analysis shall include diagrams of turning movement volumes generated by the proposed project at all study area intersections, and the Access Plan shall include turning movement volume diagrams for AM peak volumes, PM peak volumes, and any other required periods, for each of the following:

- a) Existing Conditions (based on current traffic counts)
- b) Future No-Build Conditions (Existing Conditions, plus appropriate future changes and growth factor)
- c) Project-Generated Traffic Volumes (based on trip generation)
- d) Future Build Conditions (Future No-Build Conditions, plus Project-Generated Traffic Volumes)
- e) Future Build Conditions with Mitigation (if the proponent plans to undertake any roadway or signalization changes in order to mitigate traffic impacts of the proposed project)

ii) Traffic Capacity Analysis Software: The Access Plan shall include traffic capacity analyses for existing conditions, future No-Build Conditions, and Future Build Conditions. The capacity analysis shall be performed using an approved and

(HCS) 1997 edition

- For closely-spaced intersections with long queues that create interactions between intersections, the proponent shall use a computer model, such as Transyt-7F (version 6) or Synchro, that can accurately model these interactions. In such cases, the proponent shall model all of the intersections that would interact.

The computer model output shall be attached.

iii) Traffic Capacity Analysis Results Summary. The Access Plan shall include a tabular summary of the traffic capacity analysis, for all conditions (Existing, No-Build, Build) for each intersection as a whole and for each approach of every intersection. The summary shall include the volume to capacity ratio (v/c), level of service (LOS), delay, and estimated queue length for each approach. The summary shall highlight changes to intersection and individual approach LOS that result from site-generated traffic.

iv) Traffic Counts. The proponent shall submit, under separate cover, turning movement count summary sheets for each intersection in the study area.

b. Parking Impacts. The Access Plan shall include an analysis of projected parking demand and proposed parking supply.

The parking demand analysis shall include

- Total employees in guest retail employee vs. patron split and VOR)
- Parking turnover by land use and user type (cite source)
- Parking demand peaks by land use and user type
- Overall parking demand and peak parking demand, based on shared parking among all land uses and user types included in the proposed project.

ii) Proposed Parking Supply. The Access Plan shall include a summary of the project's proposed off-street parking supply. Parking supply, and parking costs, and parking revenue, shall be included in the project's financial analysis. In addition, the project shall include a summary of the project's transit access, and the project's mode split. Appendix xx includes a map of parking ratio guidelines by land use and area of the project. The project's parking ratio shall remain within these guidelines. If the parking supply exceeds these guidelines, the proponent must justify the excess parking based on circumstances specific to the project. Higher parking ratios may increase transportation impacts, and necessitate enhanced mitigation measures. The information below shall be summarized in a clear table

- Total Spaces
 - Existing
 - Future No-Build (if applicable)
 - Future Build Parking Conditions
- Parking Allocation
 - Space allocation among various land uses
 - Parking ratios: spaces per thousand square feet or per unit, by land use
 - Specially-designated parking spaces, e.g. vanpools, livery vehicles, rental cars, car-sharing

- Treatment of existing parking spaces, including displacement of existing parking spaces and how the parking demand for these spaces would be
- Comparison of Parking Supply and Demand
 - Projected shortfall or surplus of parking spaces, by land use
 - Proposed management of shortfall or surplus
- Provide a plan of all parking facilities, including layout, access, and size of spaces.

iii) Off-Site Parking Supply. Describe any anticipated utilization of off-site parking supply (as described in the Existing Conditions) required to satisfy project-generated parking demand.

- On-Street Parking Supply
- Off-Street Parking Supply
 - Number and type of spaces required (i.e. publicly-available, employee, residential)
 - Resulting parking utilization at 12 noon on a weekday (additional parking survey times may be required, depending upon the nature of the project)

iv) Proposed Parking Management Plan

- Description of Proposed Parking Operations
 - Access control
 - Valet operations
 - Pass or payment medium
- Management of Specially-Designated Parking Spaces (e.g. vanpool, carpools, rental cars, car-sharing)
 - Location
 - Parking fees
 - Accommodation of increased supply if demand warrants

Describe the anticipated impacts of the project on the mass transit person-trips (based on trip generation). Future transit conditions shall be based on transit supply and capacity that is expected to be available in the horizon year; if there is some doubt, the proponent shall consult with DTD and/or the MBTA. The proponent may use generally available MBTA ridership data as a basis for the analysis. The Access Plan shall include the following information:

i) Transit Trip Distribution
Distribution of project-generated transit trips by zone

- Existing Conditions: Capacity and utilization by line

- No-Build Conditions: Capacity and utilization by line
- Build Conditions: Capacity and utilization by line

d. Pedestrian Impacts. Describe future pedestrian conditions in the study area:
 Pedestrian access to and from the project, pedestrian circulation routes

- Pedestrian accommodation in the project's public spaces (e.g. sidewalk, adjacent intersections, plaza spaces, benches, etc.)
- Pedestrian level of service (LOS) at all surveyed crosswalks, sidewalks and other locations
 - Existing Conditions
 - Future No-Build Conditions
 - Future Build Conditions

[NOTE: The traffic capacity analyses must also assume appropriate accommodation for pedestrians in air situation assumptions. The pedestrian impacts analysis

shall describe the assumptions regarding accommodation of pedestrians in the traffic analysis, i.e. pedestrian walk rate and percentage of cycles in which pedestrian phase is called (verify with BTD).

e. Bicycles. Describe bicycle access to, from, and within the project site. Describe bicycle storage and other amenities (e.g. shower and changing facilities) to be provided. BTD will provide guidelines on bicycle storage requirements based on project type and size.

f. Loading and Service. The project must accommodate loading and service facilities in an off-street location. The loading and service plan shall not rely upon loading facilities located in the public right of way. Describe service

and loading requirements:

- Number of loading bays
- Services to be provided (e.g. garbage compactor, garbage collection, restaurant service move-in / move-out, etc.)

Level of loading and service activity (number of trucks per day or per week)

Loading and service schedule, schedule restrictions (proponent shall prohibit or

strictly limit loading and service activity during peak periods)

Required truck turning movements (show design vehicle turning movements on site plan)

- Major loading and service vehicle routes for site access and egress
- Access for emergency vehicles

2.5 Site Plan. Provide an engineered site plan showing Build Conditions (contrast with existing conditions):

- Public right-of-way layout
 - Roadways
 - Sidewalks
- Vehicular access and circulation
- Service and loading

- Parking
- Bicycle storage
- Proposed on-street regulations

Major development projects offer benefits, but they also consume public services and create impacts on public resources. Chief among these impacts is a development's effect on the transportation system. The project proponent is required to quantify and analyze these impacts through the Access Plan. It is then the responsibility of the project proponent, working with BTD, to develop strategies for reducing and mitigating these impacts. These strategies will typically include:

These transportation system improvements and mitigation measures have associated costs. The proponent should view these costs as an integral component of the overall project cost, necessary to enable the transportation system to accommodate the project's impacts. The mitigation measures benefit the users of the transportation system, in particular the new users associated with the proposed project. Project proponents shall allocate appropriate funding for the mitigation. The mitigation measures associated with a development project will be specified in the project's Transportation Access Plan Agreement (TAPA) between the proponent and BTD.

(TDM) Travel demand management comprises a variety of strategies designed to reduce single occupancy vehicle (SOV) travel. SOV travel is a "bottleneck" of transportation (public transit, walking, bicycling, TDM programs) and is critical due to the disproportionate impacts of SOV travel on congestion, parking demand, air quality, and quality of life. TDM programs are especially important for

assumptions for mode split and VOR, since these default assumptions reflect long-standing TDM efforts and Transportation Management Association programs

A variety of TDM measures and requirements will vary depending upon the type of development, the neighborhood, the impact analysis assumptions, and other circumstances. For example, many of the measures below would not apply to a residential development. In the case of commercial office development, some (but not all) of the measures below would be the responsibility of the tenants, rather than the proponent. The proponent will be required to implement those TDM measures that are within its control, and those measures resulting from aggressive assumptions (e.g. a high transit mode share), the proponent must require appropriate TDM measures in its lease agreements with tenants.

will be required to implement the following TDM measures (as appropriate to the specific project):

c. Transportation Coordinator. Designate a full-time on-site employee as the

contact and liaison for BID and the Transportation Management Association.

- b. Ridesharing / Carpooling. Facilitate ridesharing through geographic matching and direct communication and approval of parking for carpools / vanspools. May be accomplished through membership in a TMA, participation in CARAVAN for commuters, and/or use of online services or use of computerized ridesharing software.
- c. Guaranteed Ride Home Program. Offer a "guaranteed ride home" in order to remove an obstacle to transit use and ridesharing.

d. Transit Pass Programs. Encourage employees to use transit through the following measures.

Program

Offer Federal Commuter Benefit program, including pre-tax deductions for transit passes and subsidized transit passes.

e. Information and Promotion of Travel Alternatives

Provide information on travel alternatives to employees and visitors with public transit system maps and other system information.

- Sponsor an annual (or more frequent) "Transportation Day" at which employees may obtain information on travel alternatives and participate in ridesharing programs.
- Provide information on travel alternatives for employees and visitors via the Internet.

Provide information on travel alternatives to new employees.

- f. Transportation Management Association. Encourage tenants to join the TMA as well. If no TMA is established in the project area, investigate starting a new TMA or becoming affiliated with an existing TMA. A TMA can provide many of these TDM services, including providing guaranteed ride home, and transit information and promotional materials.

g. Bicycle Facilities and Promotion

- Provide secure bicycle storage (number of spaces will be specified depending upon size of development and type of land use).
- Provide bicycle repair and changing facilities for bicycle commuters (number of spaces will be specified).
- Promote bicycles as an alternative mode of transportation through promotional materials on bicycle commuting and bicycle safety, and provide incentives for bicycle use.

h. Parking Management

- Charge market-rate parking fees
- Offer preferential parking to carpools and vanpools
- Offer reduced parking rates to carpools and vanpools
- Offer parking "cash-out" option
- Offer garage space for car rentals
- Offer parking space for car-sharing
- Offer parking space, charging facilities for electric vehicles
- Offer parking / layover space for livery vehicles (hotel development)
- Enforce a 5-minute limit on vehicle idling for all users of the Development, in accordance with Massachusetts state law

i. Trip Reduction Strategies. To the degree possible, the Developer shall implement the following strategies for its own on-site employees. The Developer shall also

telecommute.

- Flexible Work Schedules. Reduce peak hour and overall trip demand by enabling employees to telecommute, work a compressed workweek, or work hours that enable off-peak commuting.
- Local Hiring. Recruit and hire employees from the local area. Such local employees can more easily use alternatives to the automobile, including walking, bicycling, and transit.

j. Transportation Monitoring and Annual Reporting. Monitor transportation conditions,

the project, and provide benefits to the proponent. BTD will provide employee survey forms and transportation monitoring forms to ensure uniformity of data

3.2 Transportation System Improvements. In order to meet Boston's mobility needs as its population, density, and land development increase, Boston's transportation system requires improvements. These improvements offset the transportation impacts of new development. In addition, these improvements can make the traveling experience easier in the vicinity of the project, which accrues to the benefit of the proponent and the development's users.

- a. Geometric Changes and Improvements to the Public Right-of-Way. The proponent may be required to make geometric changes and improvements to roadways, sidewalks, and other elements in the vicinity of the proposed project. These changes and improvements may be necessary in order to enable new circulation patterns resulting from the project and mitigate impacts of new vehicle or pedestrian trips. Changes and improvements shall be designed by the proponent's consultant in consultation with BTD. The proponent will be required to develop and implement all changes and improvements to the public right-of-way, and to obtain

These improvements shall be made with input from BTD, per specifications provided

by BTS, by a contractor approved by BTS, and subject to final BTS inspection and approval.

b. Traffic Signal Improvements. BTS operates most of the traffic signals in Boston. Improvements to traffic signals in the vicinity of the proposed project may be necessary to manage the increased travel demands placed on the intersection. Improving the operations of these signals can reduce congestion and improve

- i) Traffic signal equipment
 - Signal controller
 - Signal heads and pedestrian heads
 - Signal poles and mast arms
- ii) Traffic monitoring equipment
 - System detectors
 - Video monitoring cameras
- iii) Traffic signal communications equipment
 - Communications conduit (4" PVC)
 - Signal interconnect cable

The project proponent will be required to directly fund and implement all traffic signal improvements, and to obtain any required permits. These improvements shall be made with input from BTS, per specifications provided by BTS, by a contractor

Public Transit System Improvements. New development can add significantly to public transit demand and have brief impacts on the transit system in order to manage this demand and mitigate the impacts, the proponent may be required to make or contribute to transit system improvements. These improvements shall be

- Dock and/or landside infrastructure improvements
- Operating subsidy for water transportation services
- Supplemental transit services. Public transit is the most desirable means of achieving transit access, and the proponent shall make every effort to facilitate transit access to the proposed project via public services. However, there may be some situations in which private supplemental transit services, such as shuttle buses, are necessary.

Overall transit demand in the area is too low to justify public transit service but the proposed project requires transit access

The proposed project generates a concentration of trips to and from certain locations, such that a shuttle is feasible and useful in reducing auto trips (e.g. locations such that a shuttle is feasible and useful in reducing auto trips (e.g. locations with high density of trips to and from certain locations).

Mitigation

The Access Plan shall include an overview of construction period transportation impacts and proposed short-term mitigation. This shall be a summary of the more detailed Construction Management Plan (CMP) that must be submitted to BTS under separate cover. The

construction management summary in the Access Plan shall provide an appropriate level of information regarding the analysis and proposed management of the impacts of the project during the construction period, including:

- The need for full or partial street closures, street occupancy, sidewalk closures, and/or sidewalk occupancy during construction
- Designated truck routes for truck movements and construction materials deliveries including designated and prohibited delivery times
- Designated truck routes
- Plans for maintaining pedestrian and vehicle access during each phase of construction
- Parking provisions for construction workers
- Mode of transportation for construction workers, initiatives for reducing driving and parking demands
- Coordination with other construction projects in the area

Information regarding construction conditions and impact mitigation is

Traffic Counts

N/S Street : Lake St / St Thomas Moore
 E/W Street: Commonwealth Avenue
 City/State : Brighton, MA
 Weather : Clear

Accurate Counts
 978-664-2565

File Name : 39000001
 Site Code : 39000001
 Start Date : 3/11/2008
 Page No : 1

Groups Printed- Cars - Trucks

Start Time	Lake St From North				Commonwealth Ave From East					St Thomas Moore Rd From South				Commonwealth Ave From West					Exclu. Total	Inclu. Total	Int. Total
	Left	Thru	Right	Peds	Left	Thru	Right	Peds	U-Trn	Left	Thru	Right	Peds	Left	Thru	Right	Peds	U-Trn			
07:00	0	0	0	4	33	58	13	0	1	7	35	11	1	32	48	0	0	1	7	237	244
07:15	0	0	0	2	37	102	26	2	2	14	42	11	5	60	64	1	0	0	11	357	368
07:30	0	0	0	5	49	126	13	4	1	18	36	7	2	46	84	1	0	1	13	380	393
07:45	0	0	0	4	56	127	20	2	2	20	56	10	5	72	148	0	3	0	16	509	525
Total	0	0	0	15	175	413	72	8	6	59	169	39	13	210	344	2	3	2	47	1483	1530
08:00	0	0	0	2	54	152	27	6	1	8	37	6	9	75	157	0	2	1	21	516	537
08:15	0	0	0	3	61	155	25	4	1	14	44	13	9	64	121	0	2	1	20	497	517
08:30	0	0	0	12	70	144	20	29	0	14	37	19	31	80	123	0	4	0	76	507	583
08:45	0	0	0	9	93	140	14	34	6	20	27	19	39	72	108	2	5	1	94	495	589
Total	0	0	0	26	278	591	86	73	8	56	145	57	88	291	509	2	13	3	211	2015	2226
Grand Total	0	0	0	41	453	1004	158	81	14	115	314	96	101	501	853	4	16	5	258	3498	3756
Apprch %	0	0	0		28	62.2	9.8			21.9	59.8	18.3		36.9	62.8	0.3					
Total %	0	0	0		13	28.7	4.5			3.3	9	2.7		14.3	24.4	0.1			6.9	93.1	
Cars	0	0	0		426	985	149			90	308	78		495	836	4			0	0	3627
% Cars	0	0	0	100	94	98.1	94.3	100	100	78.3	98.1	81.2	99	98.8	98	100	100	80	0	0	96.6
Trucks	0	0	0		27	19	9			25	6	18		6	17	0			0	0	129
% Trucks	0	0	0	0	6	1.9	5.7	0	0	21.7	1.9	18.8	1	1.2	2	0	0	20	0	0	3.4

Start Time	Lake St From North				Commonwealth Ave From East				St Thomas Moore Rd From South				Commonwealth Ave From West				Int. Total
	Left	Thru	Right	App. Total				App. Total				App. Total			App. Total		

Peak Hour Analysis From 07:00 to 08:45 - Peak 1 of 1

Accurate Counts
978-664-2565

File Name : 39000001
Site Code : 39000001
Start Date : 3/11/2008
Page No : 2

Lake St



Accurate Counts
978-664-2565

File Name : 39000001
Site Code : 39000001
Start Date : 3/11/2008
Page No : 3

Lake St
In - Peak Hour: 07:00

0
0
0

0	0	0
0	0	0
0	0	0

Right Thru Left
← ↓ →

Commonwealth Ave

81
5
86

Right Thru
← ↓

Commonwealth Ave

St Thomas Moore Rd

Accurate Counts
978-664-2565

File Name : 39000001
Site Code : 39000001
Start Date : 3/11/2008
Page No : 1

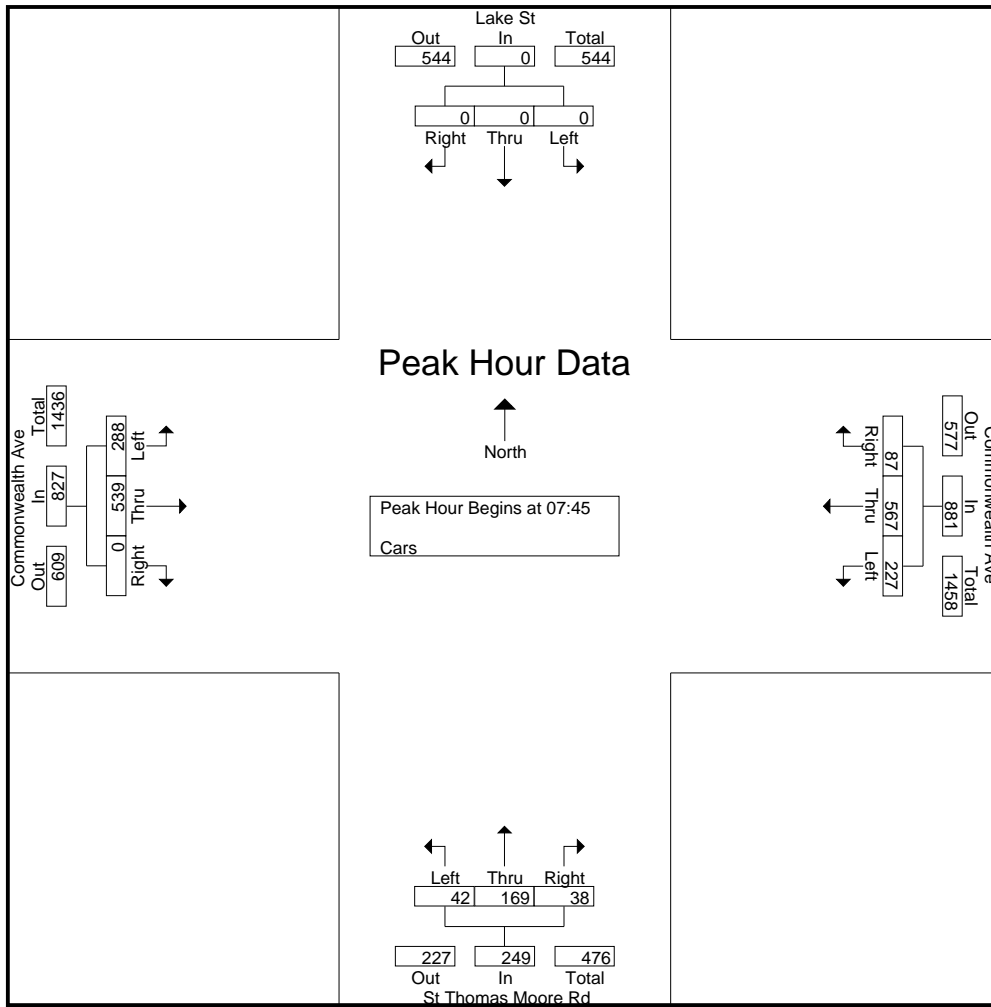

Peak Hour Analysis From 07:00 to 08:45 - Peak 1 of 1

Peak Hour for Each Approach Begins at:

+0 mins.	07:00	08:00	07:45	07:45
	0	0	0	0

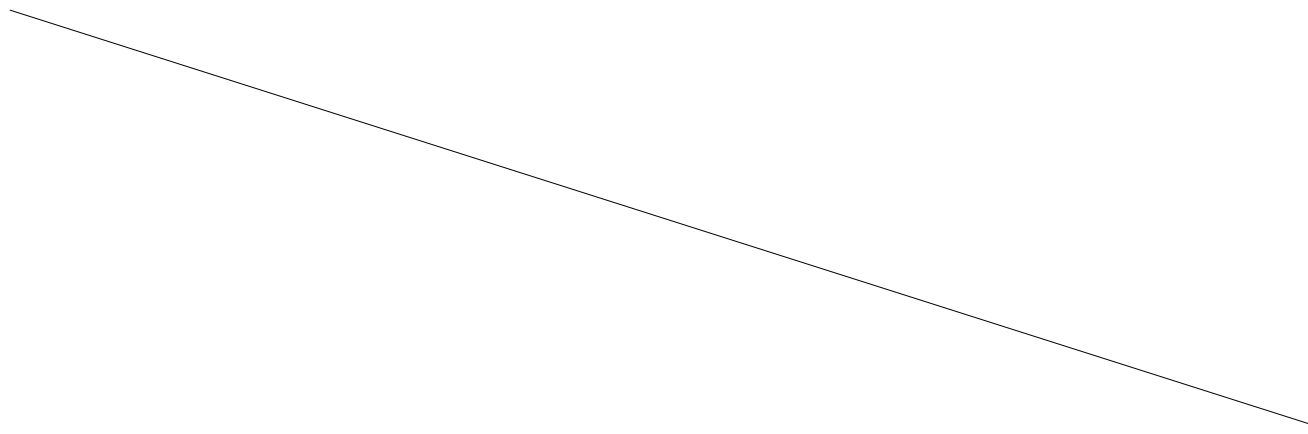

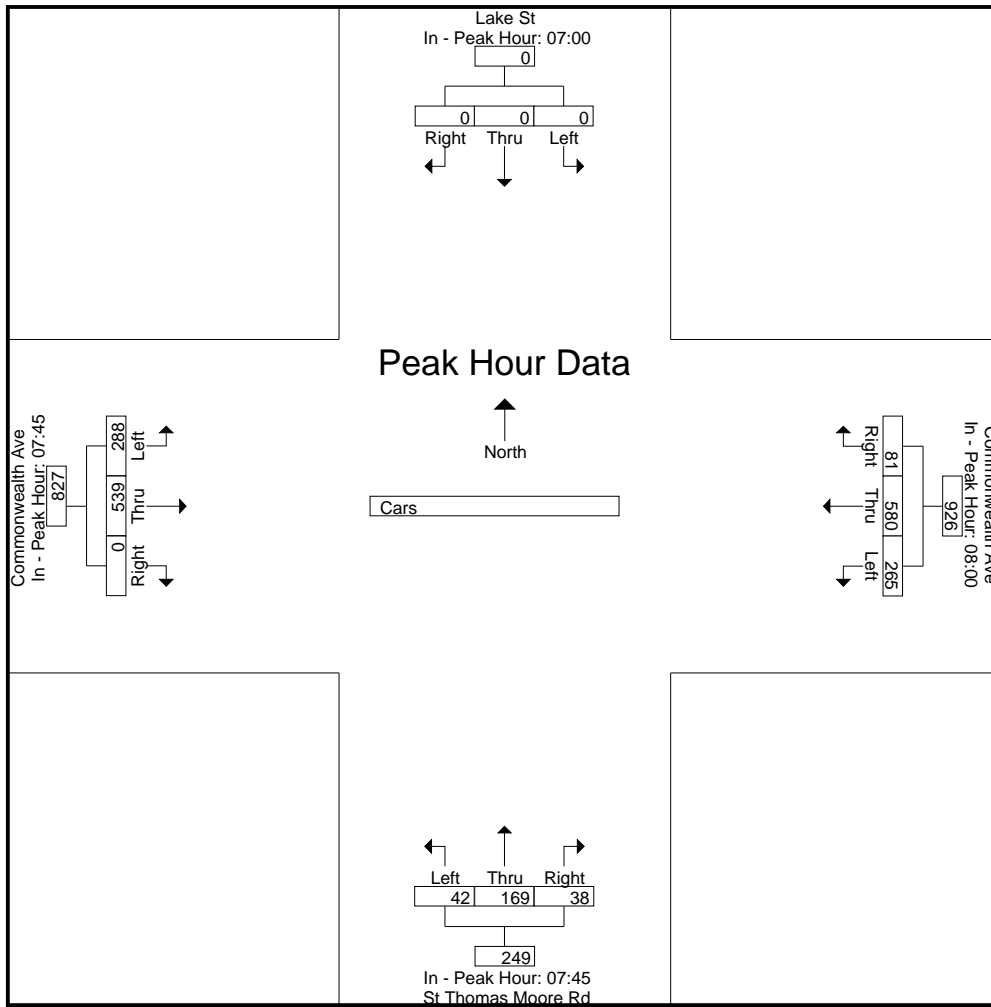

N/S Street : Lake St / St Thomas Moore
 E/W Street: Commonwealth Avenue
 City/State : Brighton, MA
 Weather : Clear

Accurate Counts
 978-664-2565

File Name : 39000001
 Site Code : 39000001
 Start Date : 3/11/2008
 Page No : 1

Groups Printed- Trucks

Start Time	Lake St From North				Commonwealth Ave From East					St Thomas Moore Rd From South				Commonwealth Ave From West					Exclu. Total	Inclu. Total	Int. Total
	Left	Thru	Right	Peds	Left	Thru	Right	Peds	U-Trn	Left	Thru	Right	Peds	Left	Thru	Right	Peds	U-Trn			
07:00	0	0	0	0	4	1	1	0	0	2	1	2	1	0	1	0	0	1	2	12	14
07:15	0	0	0	0	2	1	2	0	0	3	0	2	0	1	0	0	0	0	0	11	11
07:30	0	0	0	0	4	3	0	0	0	3	0	2	0	1	3	0	0	0	0	16	16
07:45	0	0	0	0	4	3	1	0	0	5	0	2	0	1	4	0	0	0	0	20	20
Total	0	0	0	0	14	8	4	0	0	13	1	8	1	3	8	0	0	1	2	59	61
08:00	0	0	0	0	1	2	0	0	0	2	1	2	0	0	2	0	0	0	0	10	10
08:15	0	0	0	0	5	2	3	0	0	4	1	2	0	0	1	0	0	0	0	18	18
08:30	0	0	0	0	4	4	1	0	0	3	3	4	0	2	3	0	0	0	0	24	24
08:45	0	0	0	0	3	3	1	0	0	3	3	4	0	2	3	0	0	0	0	16	16
Total	0	0	0	0	13	11	5	0	0	12	8	13	0	4	9	0	0	0	0	46	46

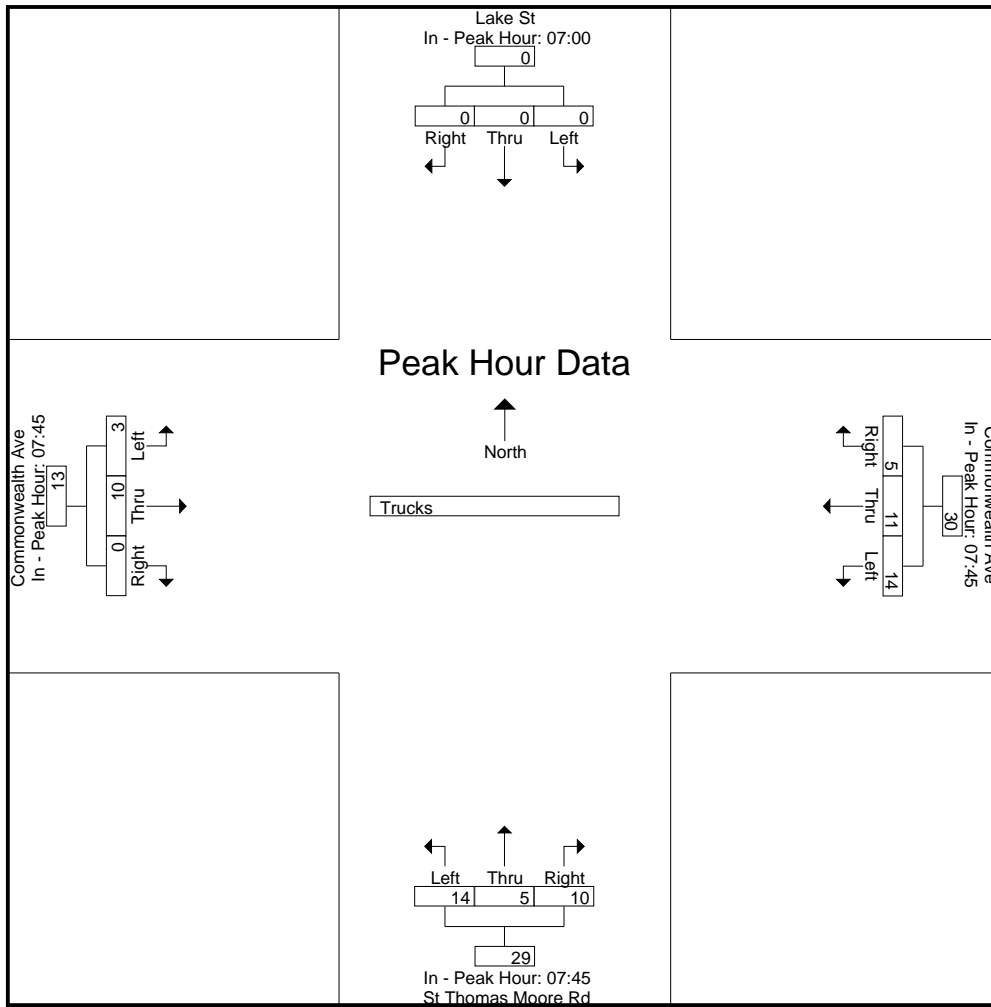

Accurate Counts
978-664-2565

File Name : 39000001
Site Code : 39000001
Start Date : 3/11/2008
Page No : 2

Lake St		Total
Out	In	
520	0	520
2	0	2
522	0	522

Right	Thru	Left
0	0	0
0	0	0
0	0	0

Commonwealth Ave

Commonwealth Ave		Total
Out	In	
518	993	1511
10	8	18
528	1001	1529

Right	Thru	Left
114	674	205
1	0	7
115	674	212

Left	Thru	Right
157	242	71
1	1	1
158	243	72

St Thomas Moore Rd

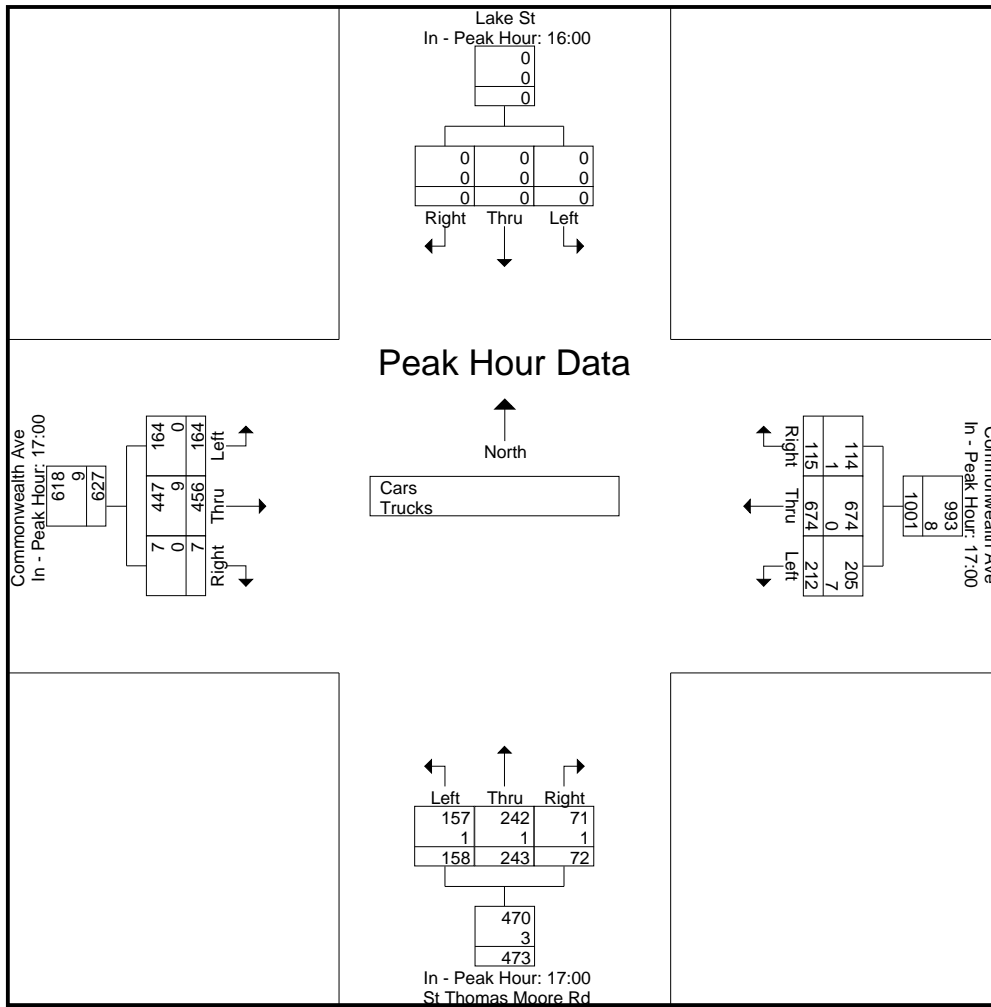

N/S Street : Lake St / St Thomas Moore
E/W Street: Commonwealth Avenue
City/State : Brighton, MA
Weather : Clear

Accurate Counts
978-664-2565

File Name : 39000001
Site Code : 39000001
Start Date : 3/11/2008
Page No : 1

Groups Printed- Cars

Start Time	Lake St From North			Commonwealth Ave From East	St Thomas Moore Rd From South	Commonwealth Ave From West
	Left	Thru	Right			
				x 18 69Cht		

Accurate Counts
978-664-2565

File Name : 39000001
Site Code

Accurate Counts
978-664-2565

File Name : 39000001
Site Code : 39000001
Start Date : 3/11/2008
Page No : 3

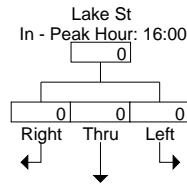

Commonwealth Ave

Commonwealth Ave

St Thomas Moore Rd

N/S Street : Lake St / St Thomas Moore
 E/W Street: Commonwealth Avenue
 City/State : Brighton, MA
 Weather : Clear

Accurate Counts
 978-664-2565

File Name : 39000001
 Site Code : 39000001
 Start Date : 3/11/2008
 Page No : 1

Groups Printed- Trucks

Start Time	Lake St From North				Commonwealth Ave From East					St Thomas Moore Rd From South				Commonwealth Ave From West					Exclu. Total	Inclu. Total	Int. Total	
	Left	Thru	Right	Peds	Thru	Left	Thru	Right	Peds	U-Trn	Left	Thru	Right	Peds	Left	Thru	Right	Peds				U-Trn
16:00	0	0	0																	0		

Accurate Counts
978-664-2565

File Name : 39000001
Site Code : 39000001
Start Date : 3/11/2008
Page No : 2

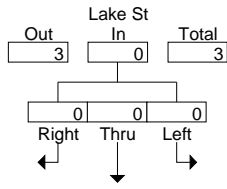

Commonwealth Ave

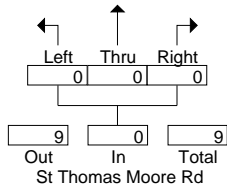
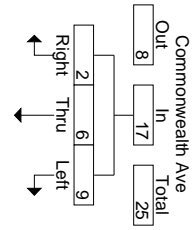

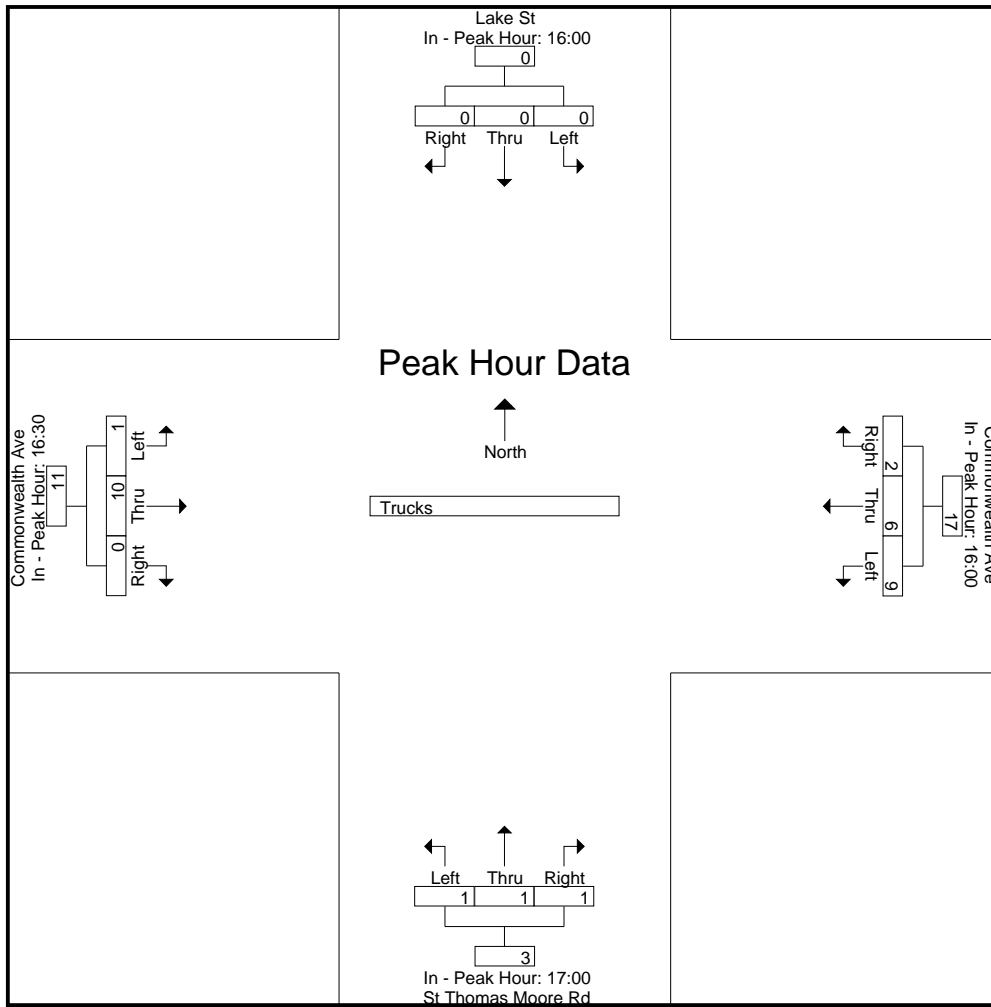

N/S Street : Foster Street
 E/W Street: Commonwealth Avenue
 City/State : Brighton, MA
 Weather : Clear

Accurate Counts
 978-664-2565

File Name : 39000002
 Site Code : 39000002
 Start Date : 3/11/2008
 Page No : 1

Groups Printed- Cars - Trucks

Start Time	Foster St From North			Commonwealth Ave From East			Commonwealth Ave From West			Exclu. Total	Inclu. Total	Int. Total
	Left	Right	Peds	Thru	Right	Peds	Left	Thru	Peds			
07:00	0	45	5	65	10	0	0	73	0	5	193	198
07:15	0	66	8	115	15	0	0	86	0	8	282	290
07:30	0	92	9	114	17	0	0	109	0	9	332	341
07:45	0	79	15	142	19	0	0	160	0	15	400	415
Total	0	282	37	436	61	0	0	428	0	37	1207	1244
08:00	0	76	6	156	26	0	0	165	0	6	423	429
08:15	0	97	9	160	16	0	0	145	0	9	418	427
08:30	0	99	29	155	19	0	0	146	0	29	419	448
08:45	0	105	18	144	19	0	0	133	0	18	401	419
Total	0	377	62	615	80	0	0					

Accurate Counts
978-664-2565

File Name : 39000002
Site Code : 39000002
Start Date : 3/11/2008
Page No : 2

Foster St

Commonwealth Ave

Commonwealth Ave

N/S Street : Foster Street
 E/W Street: Commonwealth Avenue
 City/State : Brighton, MA
 Weather : Clear

Accurate Counts
 978-664-2565

File Name : 39000002
 Site Code : 39000002
 Start Date : 3/11/2008
 Page No : 1

Groups Printed- Cars

Start Time	Foster St From North			Commonwealth Ave From East			Commonwealth Ave From West			Exclu. Total	Inclu. Total	Int. Total
	Left	Right	Peds	Thru	Right	Peds	Left	Thru	Peds			
07:00	0	44	5	62	10	0	0	70	0	5	186	

Accurate Counts
978-664-2565

File Name : 39000002
Site Code : 39000002
Start Date : 3/11/2008
Page No : 2

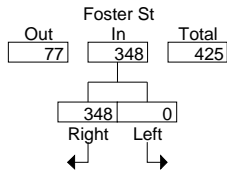

Commonwealth Ave

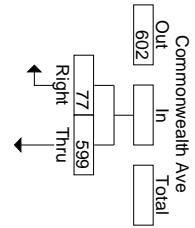

Accurate Counts
978-664-2565

File Name : 39000002
Site Code : 39000002
Start Date : 3/11/2008
Page No : 3

N/S Street : Foster Street
 E/W Street: Commonwealth Avenue
 City/State : Brighton, MA
 Weather : Clear

Accurate Counts
 978-664-2565

File Name : 39000002
 Site Code : 39000002
 Start Date : 3/11/2008
 Page No : 1

Groups Printed- Trucks

Start Time	Foster St From North			Commonwealth Ave From East			Commonwealth Ave From West			Exclu. Total	Inclu. Total	Int. Total
	Left	Right	Peds	Thru	Right	Peds	Left	Thru	Peds			
07:00	0	1	0	3	0	0	0	3	0	0	7	7
07:15	0	2	0	4	0	0	0	3	0	0	9	9
07:30	0	3	0	3	0	0	0	7	0	0	13	13
07:45	0	1	0	3	0	0	0	4	0	0	8	8
Total	0	7	0	13	0	0	0	17	0	0	37	37
08:00	0	0	0	3	1	0	0	3	0	0	7	7
08:15	0	1	0	5	2	0	0	2	0	0	10	10
08:30	0	1	0	3	0	0	0	5	0	0	9	9
08:45	0	2	0	5	0	0	0	5	0	0	12	12
Total	0	4	0	16	3	0	0	15	0	0	38	38
Grand Total	0	11	0	29	3	0	0	32	0	0	75	75
Apprch %	0	100		90.6	9.4		0	100				
Total %	0	14.7		38.7	4		0	42.7		0	100	

Start Time	Foster St From North			Commonwealth Ave From East			Commonwealth Ave From West			Int. Total
	Left	Right	App. Total	Thru	Right	App. Total	Left	Thru	App. Total	
07:30	0	3	3	3	0	3	0	7	7	13
07:45	0	1	1	3	0	3	0	4	4	8
08:00	0	0	0	3	1	4	0	3	3	7
08:15	0	1	1	5	2	7	0	2	2	10
Total Volume	0	5	5	14	3	17	0	16	16	38
% App. Total	0	100		82.4	17.6		0	100		
PHF	.000	.417	.417	.700	.375	.607	.000	.571	.571	.731

Peak Hour Analysis From 07:00 to 08:45 - Peak 1 of 1
 Peak Hour for Entire Intersection Begins at 07:30

Accurate Counts
978-664-2565

File Name : 39000002
Site Code : 39000002
Start Date : 3/11/2008
Page No : 2

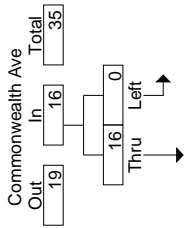
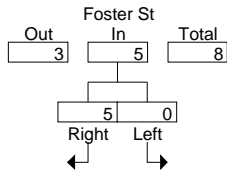

Peak Hour Begins at 07:30

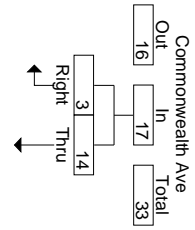

Accurate Counts
978-664-2565

File Name : 39000002
Site Code : 39000002
Start Date : 3/11/2008
Page No : 3

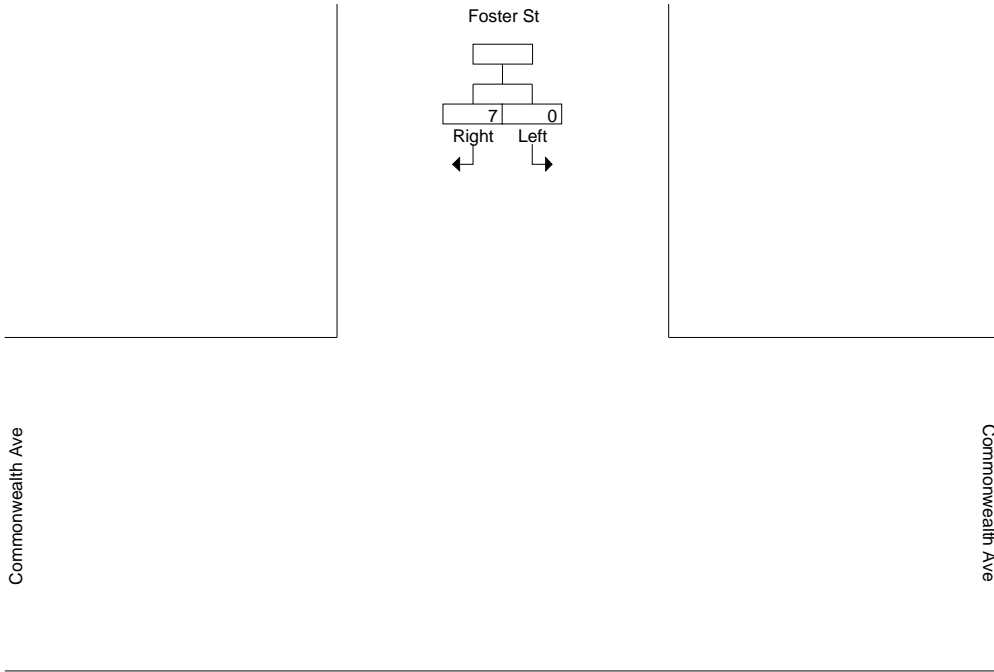

N/S Street : Foster Street

Accurate Counts
978-664-2565

File Name : 39000002
Site Code : 39000002
Start Date : 3/11/2008
Page No : 1

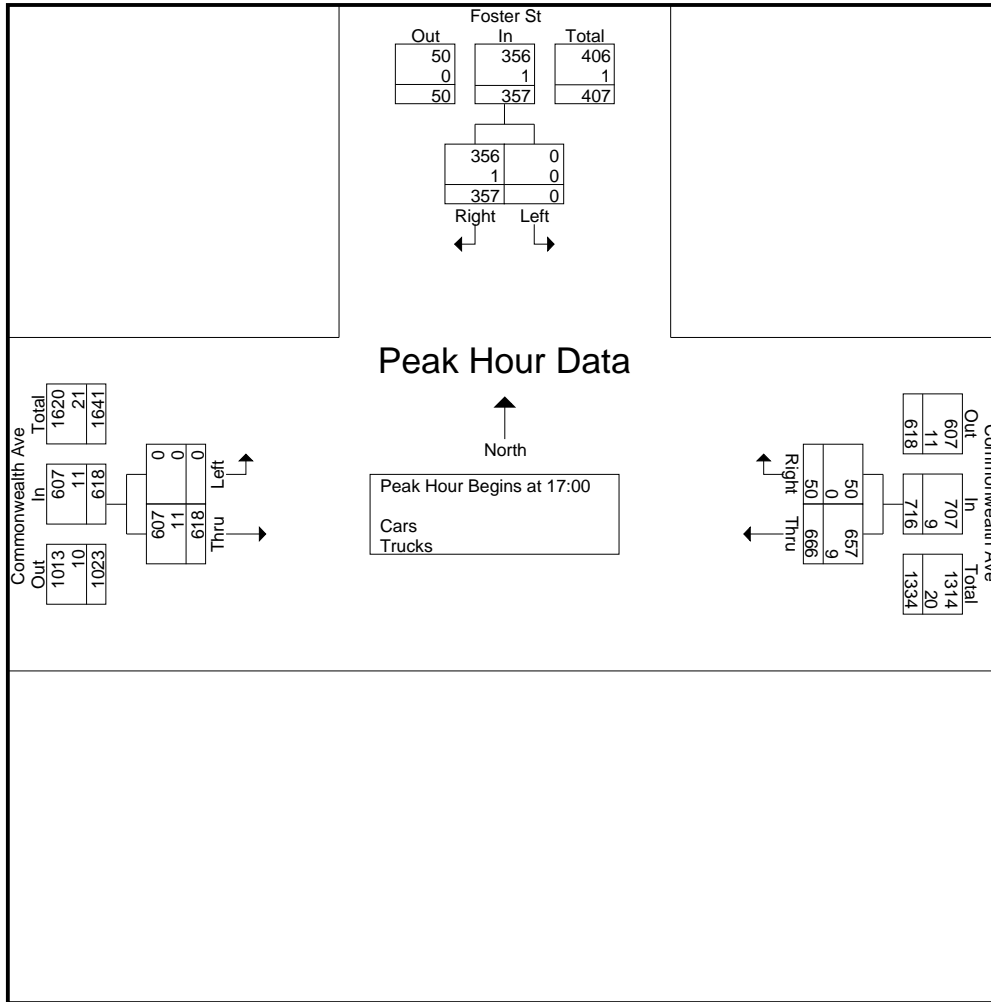

Peak Hour Analysis From 16:00 to 17:45 - Peak 1 of 1

Peak Hour for Each Approach Begins at:

	17:00			17:00			17:00		
+0 mins.	0	79	79	161	9	170	0	147	147
+15 mins.	0	100	100	178	11	189	0	145	145
+30 mins.	0	88	88	160	13	173	0	140	140
+45 mins.	0	90	90	167	17	184	0	186	186
Total Volume	0	357	357	666	50	716	0	618	618
% App. Total	0	100		93	7		0	100	
PHF	.000	.893	.893	.935	.735	.947	.000	.831	.831
Cars	0	356	356	657	50	707	0	607	607
% Cars	0	99.7	99.7	98.6	100	98.7	0	98.2	98.2
Trucks	0	1	1	9	0	9	0	11	11
% Trucks	0	0.3	0.3	1.4	0	1.3	0	1.8	1.8

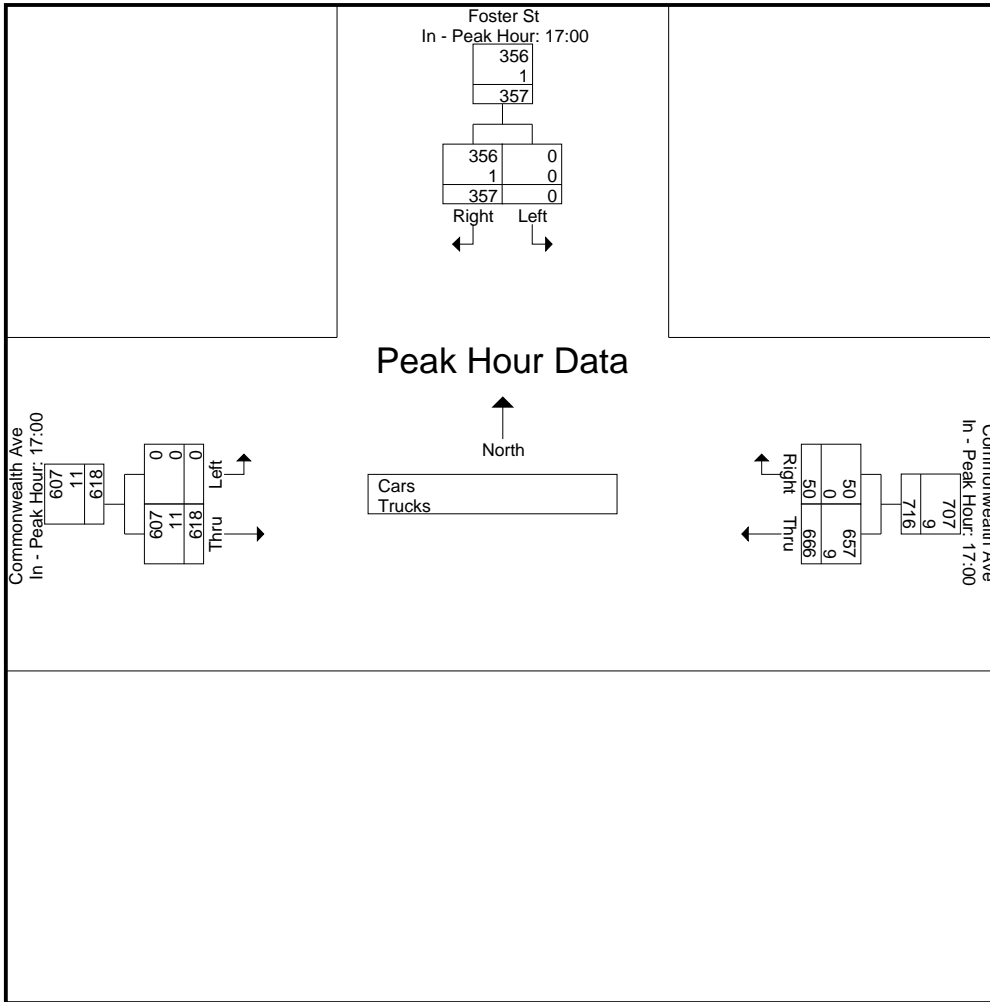

N/S Street : Foster Street
 E/W Street: Commonwealth Avenue
 City/State : Brighton, MA
 Weather : Clear

Accurate Counts
 978-664-2565

File Name : 39000002
 Site Code : 39000002
 Start Date : 3/11/2008
 Page No : 1

Groups Printed- Cars

Start Time	Foster St From North			Commonwealth Ave From East			Commonwealth Ave From West			Exclu. Total	Inclu. Total	Int. Total
	Left	Right	Peds	Thru	Right	Peds	Left	Thru	Peds			
16:00	0	83	13	124	10	4	0	95	0	17	312	329
16:15	0	82	11	162	14	0	0	113	0	11	371	382
16:30	0	76	14	110	12	0	0	127	0	14	325	339
16:45	0	84	14	141	14	0	0	144	0	14	383	397
Total	0	325	52	537	50	4	0	479	0	56	1391	1447
17:00	0	78	14	159	9	0	0	144	0	14	390	404
17:15	0	100	9	176	11	0	0	142	0	9	429	438
17:30	0	88	20	157	13	0	0	138	0	20	396	416
17:45	0	90	22	165	17	0	0	183	0	22	455	477
Total	0	356	65	657	50	0	0	607	0	65	1670	1735
Grand Total	0	681	117	1194	100	4	0	1086	0	121	3061	3182
Apprch %	0	100		92.3	7.7		0	100				
Total %	0	22.2		39	3.3		0	35.5		3.8	96.2	

Start Time	Foster St From North			Commonwealth Ave From East			Commonwealth Ave From West			Int. Total
	Left	Right	App. Total	Thru	Right	App. Total	Left	Thru	App. Total	
17:00	0	78	78	159	9	168	0	144	144	390
17:15	0	100	100	176	11	187	0	142	142	429
17:30	0	88	88	157	13	170	0	138	138	396
17:45	0	90	90	165	17	182	0	183	183	455
Total Volume	0	356	356	657	50	707	0	607	607	1670
% App. Total	0	100		92.9	7.1		0	100		
PHF	.000	.890	.890	.933						

Peak Hour Analysis From 16:00 to 17:45 - Peak 1 of 1
 Peak Hour for Entire Intersection Begins at 17:00

Accurate Counts
978-664-2565

File Name : 39000002
Site Code : 39000002
Start Date : 3/11/2008
Page No : 2

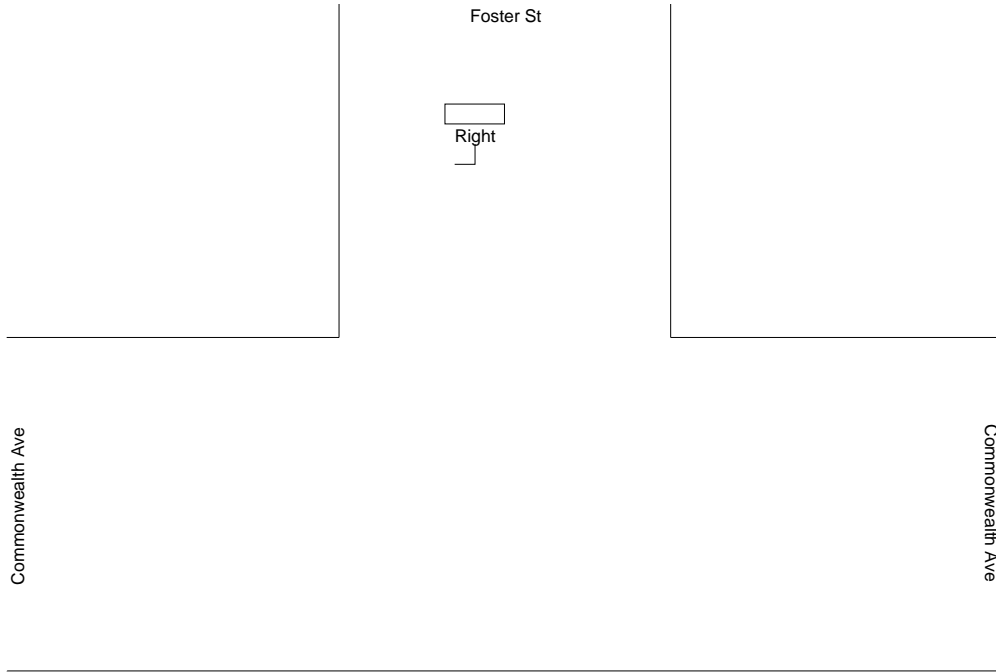

Accurate Counts
978-664-2565

File Name : 39000002
Site Code : 39000002
Start Date : 3/11/2008
Page No : 3

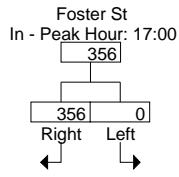

Commonwealth Ave

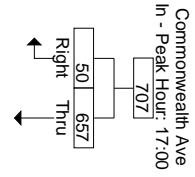
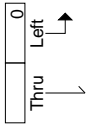

Accurate Counts

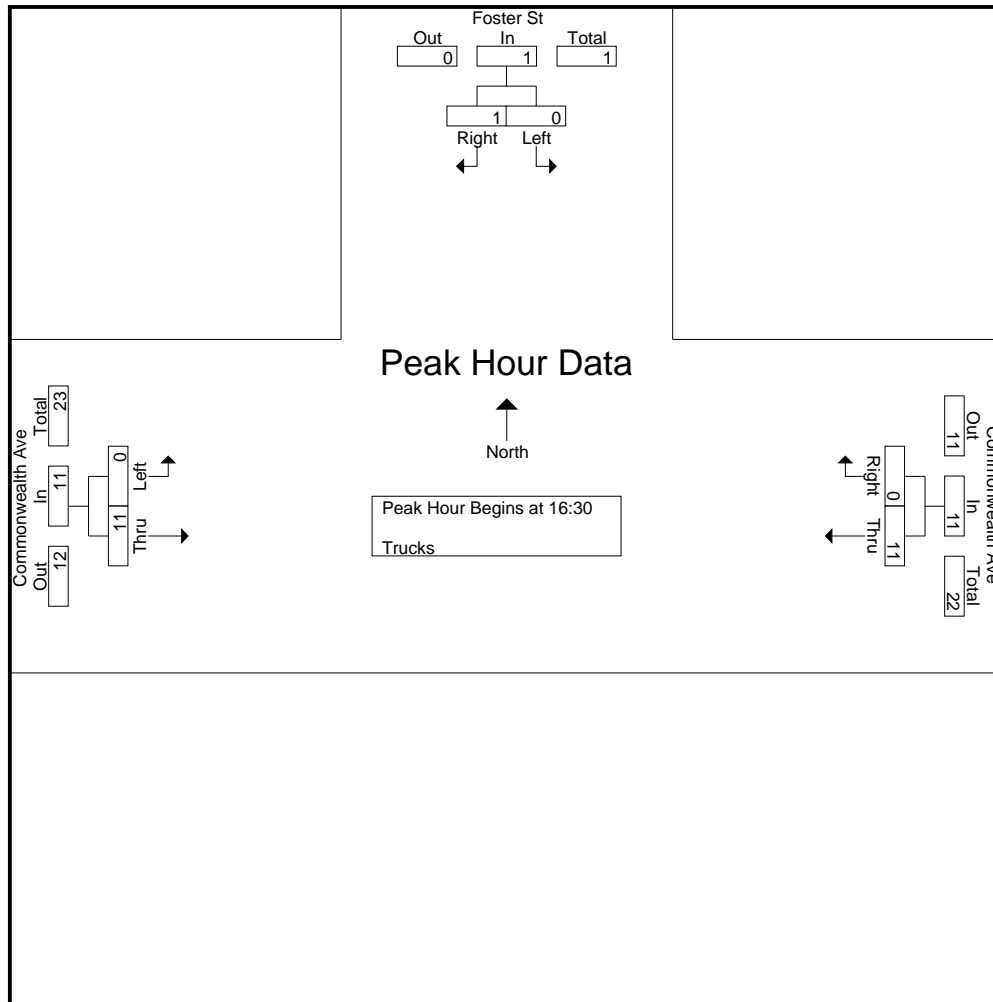

Peak Hour Analysis From 16:00 to 17:45 - Peak 1 of 1

Peak Hour for Each Approach Begins at:

	16:15			16:00			16:30		
+0 mins.	0	0	0	4	0	4	0	3	3
+15 mins.	0	0	0	2	0	2	0	2	2
+30 mins.	0	0	0	4	0	4	0	3	3
+45 mins.	0	1	1	3	0	3	0	3	3
Total Volume	0	1	1	13	0	13	0	11	11
% App. Total	0	100		100	0		0	100	
PHF	.000	.250	.250	.813	.000	.813	.000	.917	.917

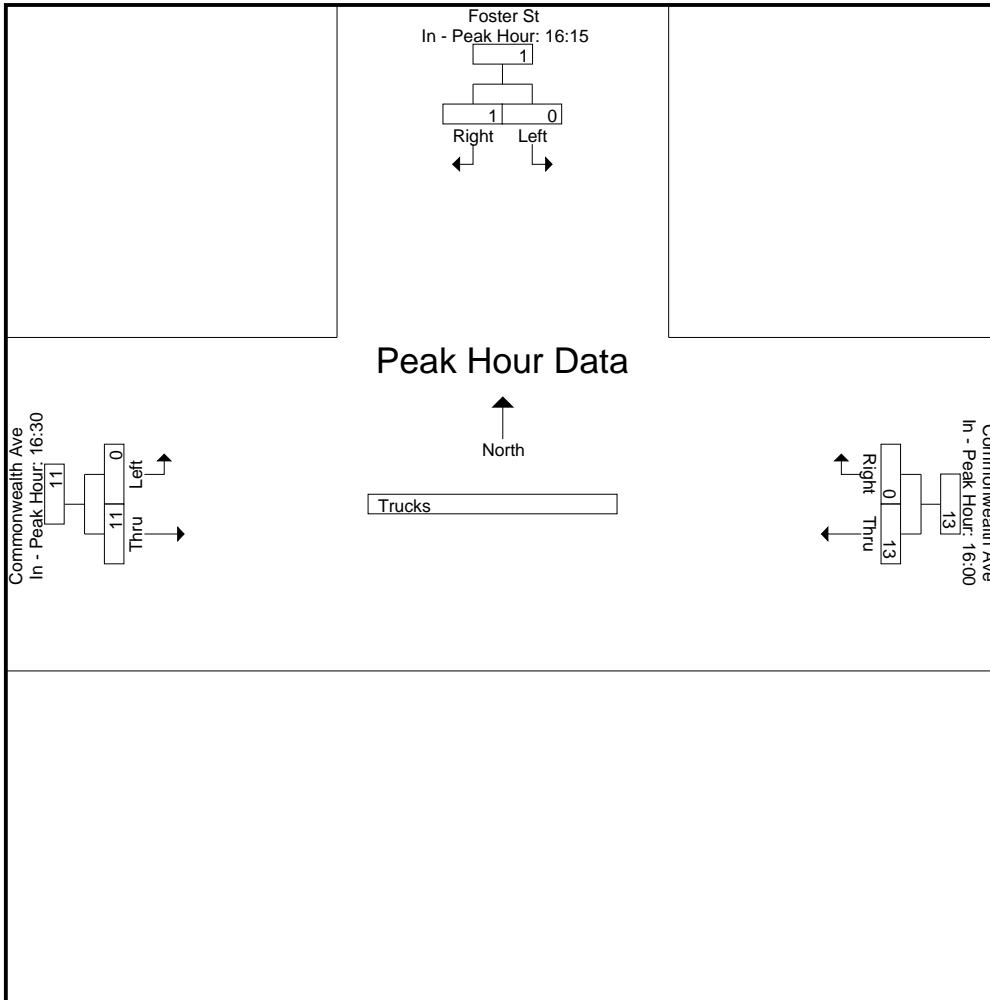

Accurate Counts
978-664-2565

File Name : 3900003
Site Code : 3900003
Start Date : 3/11/2008
Page No : 2

Chestnut Hill Ave

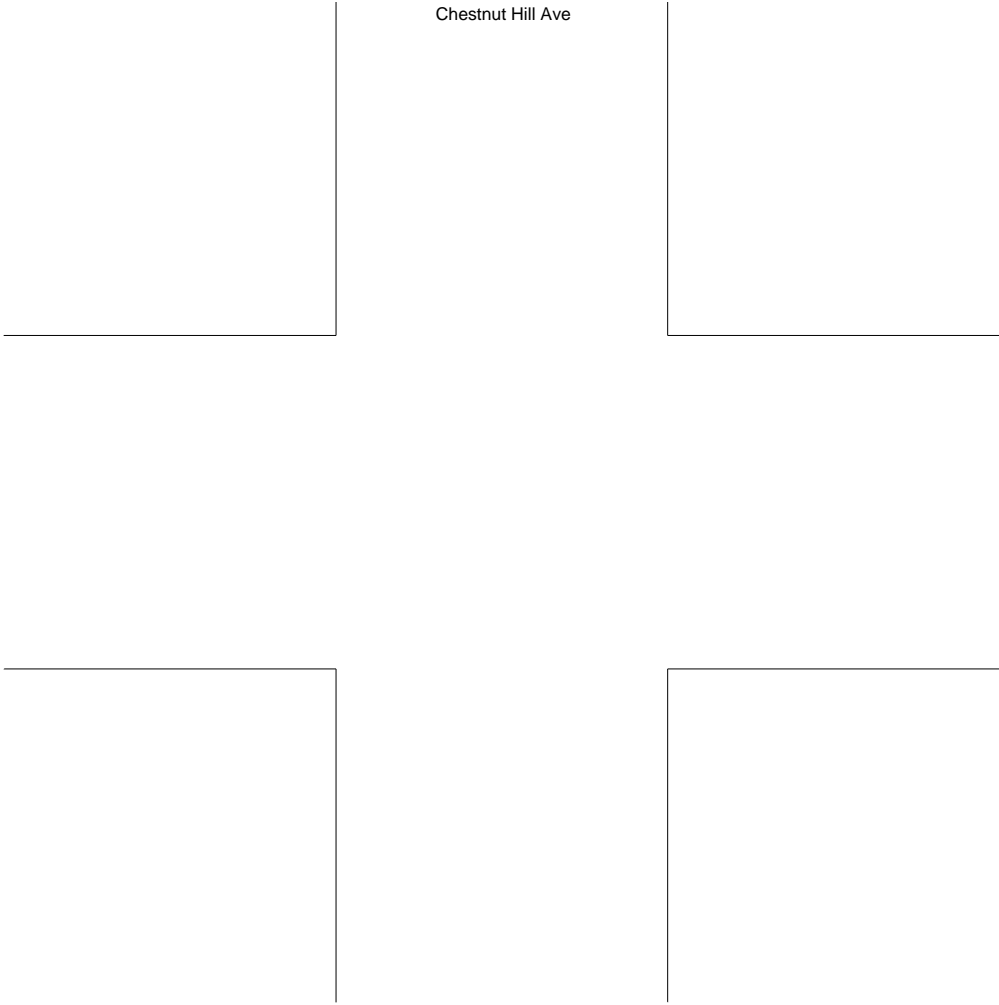

Accurate Counts
978-664-2565

File Name : 3900003
Site Code : 3900003
Start Date : 3/11/2008
Page No : 3

Chestnut Hill Ave
In - Peak Hour: 07:30

493		
24		
517		
33	430	30
1	23	0
34	453	30
Right	Thru	Left

Commonwealth Avenue

13	273	373
4	12	
17	285	
Right	Thru	Left

Commonwealth Avenue

BT-0.-1.1.-0.439.2.491.58 Tm-6.61 Ts (373)

Chestnut Hill Ave

N/S Street : Chestnut Hill Avenue
E/W Street: Commonwealth Avenue
City/State : Boston, MA
Weather : Clear

Accurate Counts
978-664-2565

File Name : 3900003
Site Code : 3900003
Start Date : 3/11/2008
Page No : 1

	Chestnut Hill Ave
--	-------------------

Groups Printed- Cars

Accurate Counts
978-664-2565

File Name : 3900003
Site Code : 3900003
Start Date : 3/11/2008
Page No : 2

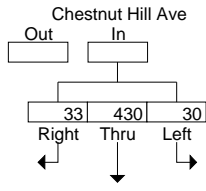

Commonwealth Avenue

Commonwealth Avenue

Chestnut Hill Ave

Accurate Counts
978-664-2565

File Name : 3900003
Site Code : 3900003
Start Date : 3/11/2008
Page No : 3

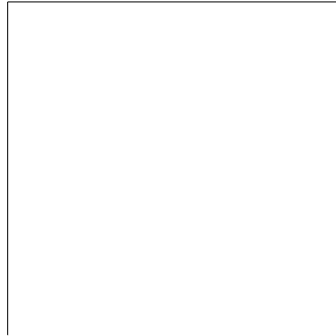
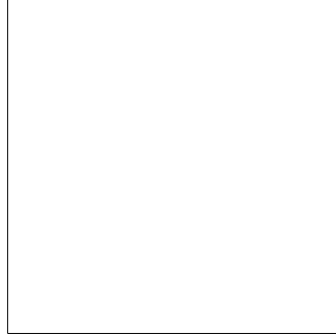

Accurate Counts
978-664-2565

File Name : 3900003
Site Code : 3900003
Start Date : 3/11/2008
Page No : 2

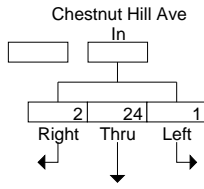

Commonwealth Avenue

Commonwealth Avenue

Chestnut Hill Ave

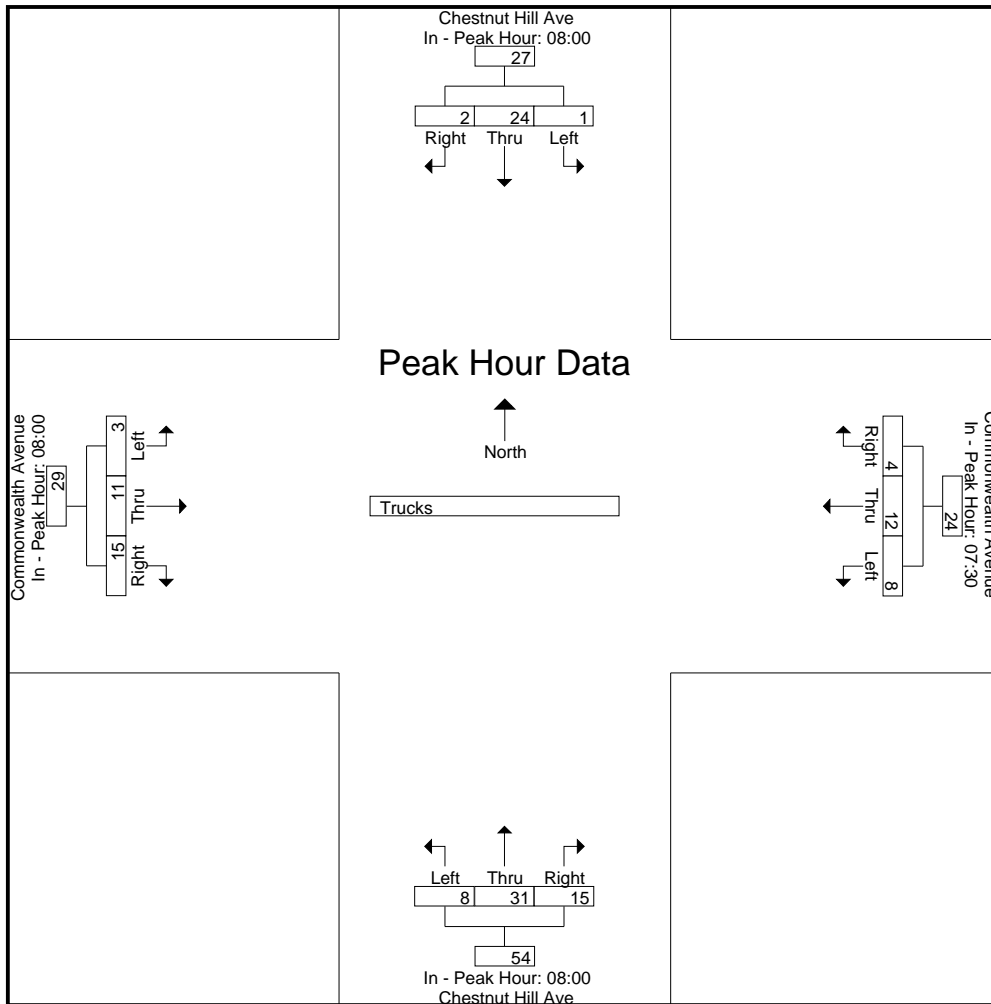

N/S Street : Chestnut Hill Avenue
 E/W Street: Commonwealth Avenue
 City/State : Boston, MA
 Weather : Clear

Accurate Counts
 978-664-2565

File Name : 3900003
 Site Code : 3900003
 Start Date : 3/11/2008
 Page No : 1

Groups Printed- Cars - Trucks

Start Time	Chestnut Hill Ave From North				Commonwealth Avenue From East			Chestnut Hill Ave From South			Commonwealth Avenue From West		
	Left	Thru	Right	Peds	Left	Thru	Right	Left	Thru	Right	Left	Thru	Right

Left

Left

Accurate Counts
978-664-2565

File Name : 3900003
Site Code : 3900003
Start Date : 3/11/2008
Page No : 3

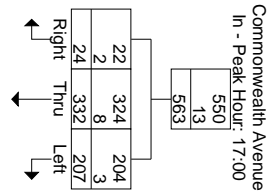
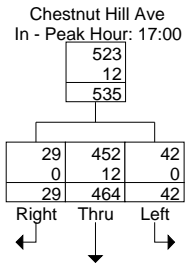

Commonwealth Avenue

Chestnut Hill Ave

N/S Street : Chestnut Hill Avenue
 E/W Street: Commonwealth Avenue
 City/State : Boston, MA
 Weather : Clear

Accurate Counts
 978-664-2565

File Name : 3900003
 Site Code : 3900003
 Start Date : 3/11/2008
 Page No : 1

Groups Printed- Cars

Start Time	Chestnut Hill Ave From North				Commonwealth Avenue From East					Chestnut Hill Ave From South				Commonwealth Avenue From West				Exclu. Total	Inclu. Total	Int. Total
	Left	Thru	Right	Peds	Left	Thru	Right	U-Trn	Peds	Left	Thru	Right	Peds	Left	Thru	Right	Peds			
16:00	13	93	1	15	46	48	5	1	37	46	100	29	14	7	55	38	7	74	481	555
16:15	9	99	8	17	55	72	9	0	44	36	362	31	8	23	65	27	1	70	506	576
16:30	7	108	10	8	46-23.72 637.74 m 393 10-8 9 Td -83.Tj ET BT 356.82180.96 628.49 Td -8 Ts9 9															

8 65

Accurate Counts
978-664-2565

File Name : 3900003
Site Code : 3900003
Start Date : 3/11/2008
Page No : 2

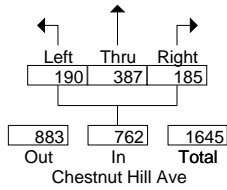
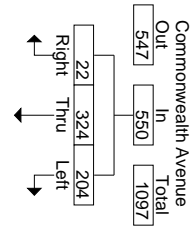
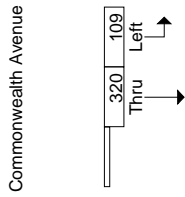
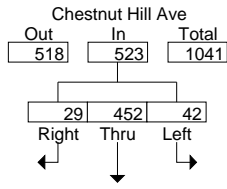

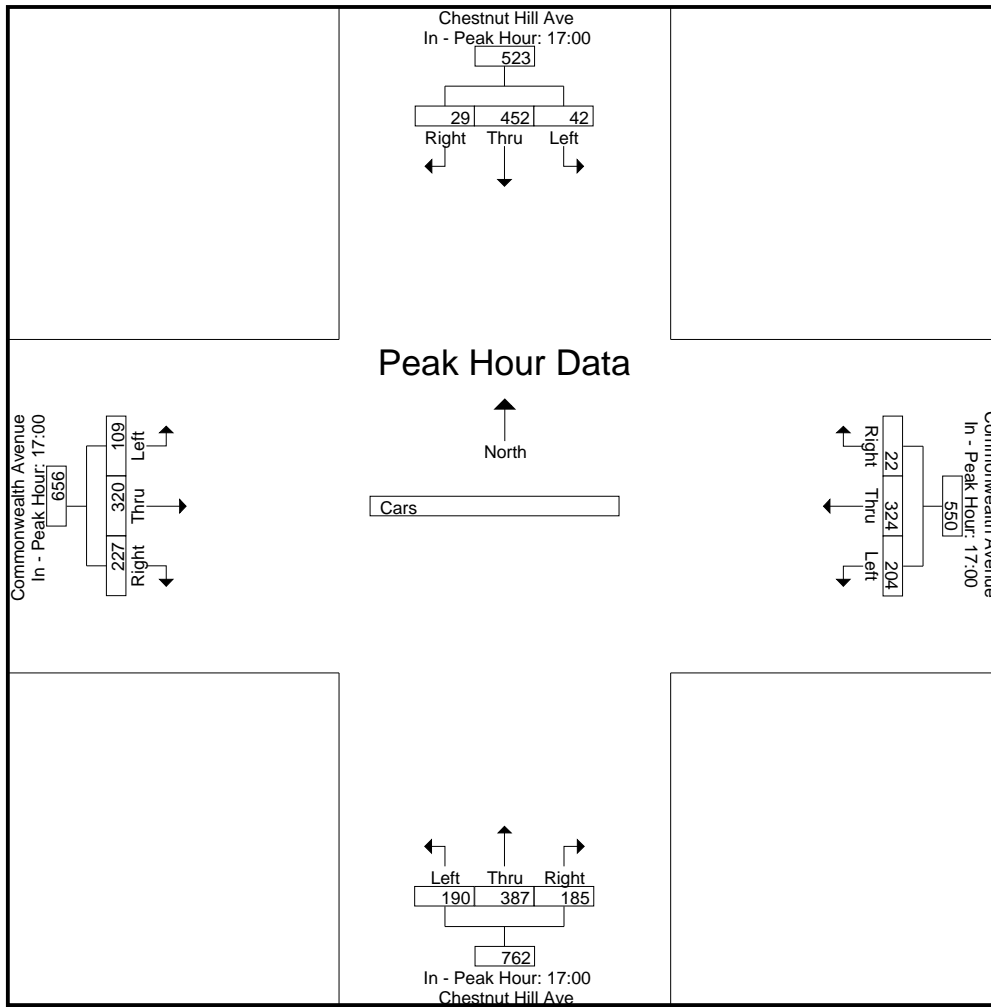

N/S Street : Chestnut Hill Avenue
E/W Street: Commonwealth Avenue

Accurate Counts
978-664-2565

File Name : 3900003
Site Code : 3900003
Start Date : 3/11/2008
Page No : 1

Accurate Counts
978-664-2565

File Name : 3900003
Site Code : 3900003

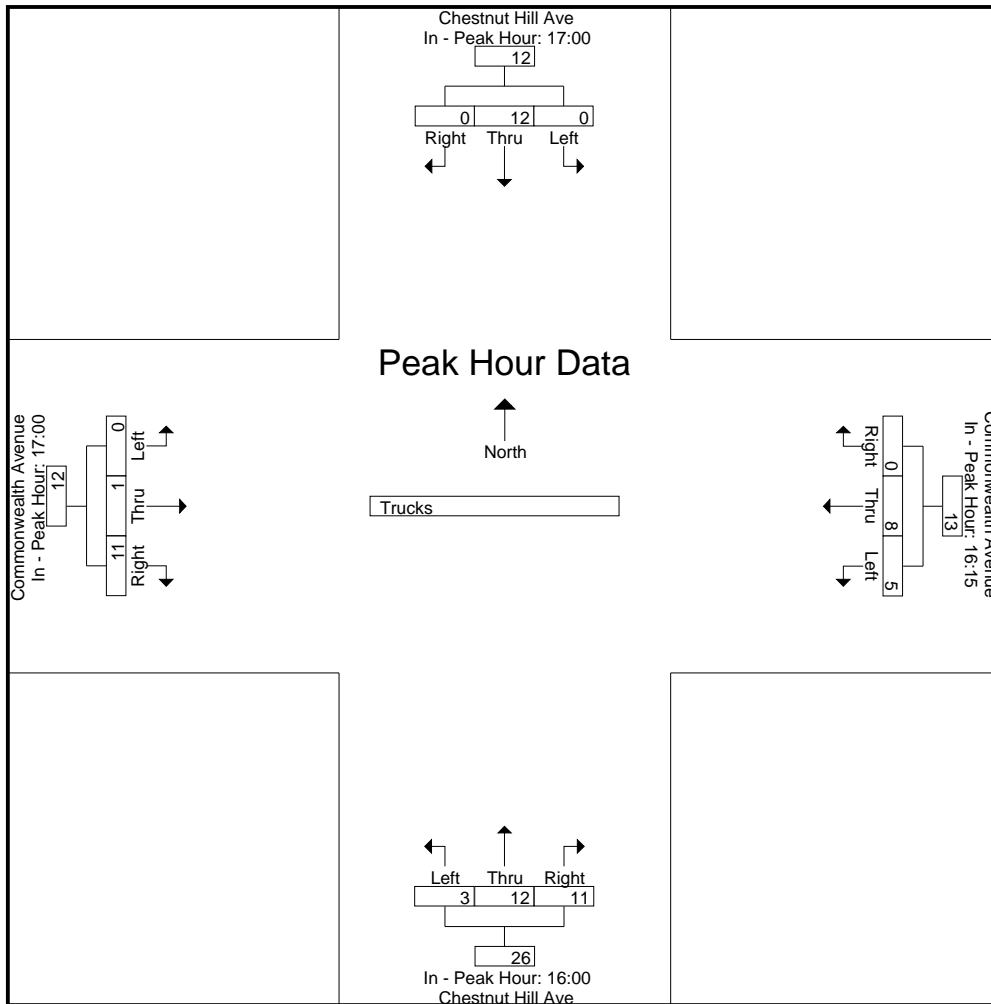

Accurate Counts
978-664-2565

File Name : 39000004
Site Code : 39000004
Start Date : 3/11/2008
Page No : 2

Mt Alvernia Rd

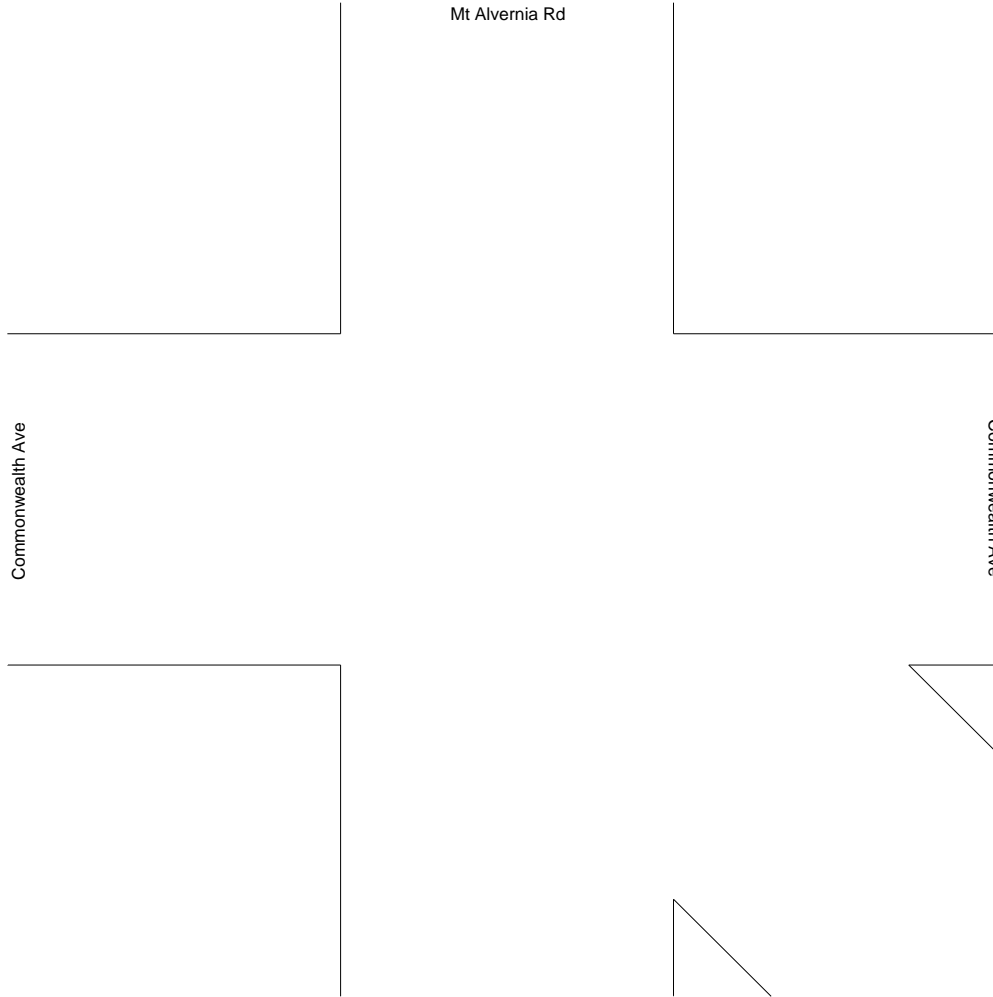

Accurate Counts
978-664-2565

File Name : 39000004
Site Code : 39000004
Start Date : 3/11/2008
Page No : 3

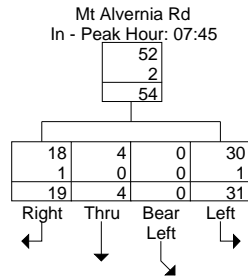

Commonwealth Ave

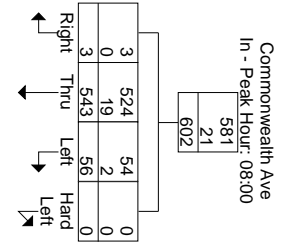

Old Colony Rd

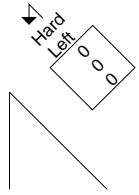

College Rd

N/S Street : Old Colony Road
E/W Street: Commonwealth Avenue

Accurate Counts
978-664-2565

File Name : 39000004
Site Code : 39000004
Start Date : 3/11/2008
Page No : 1

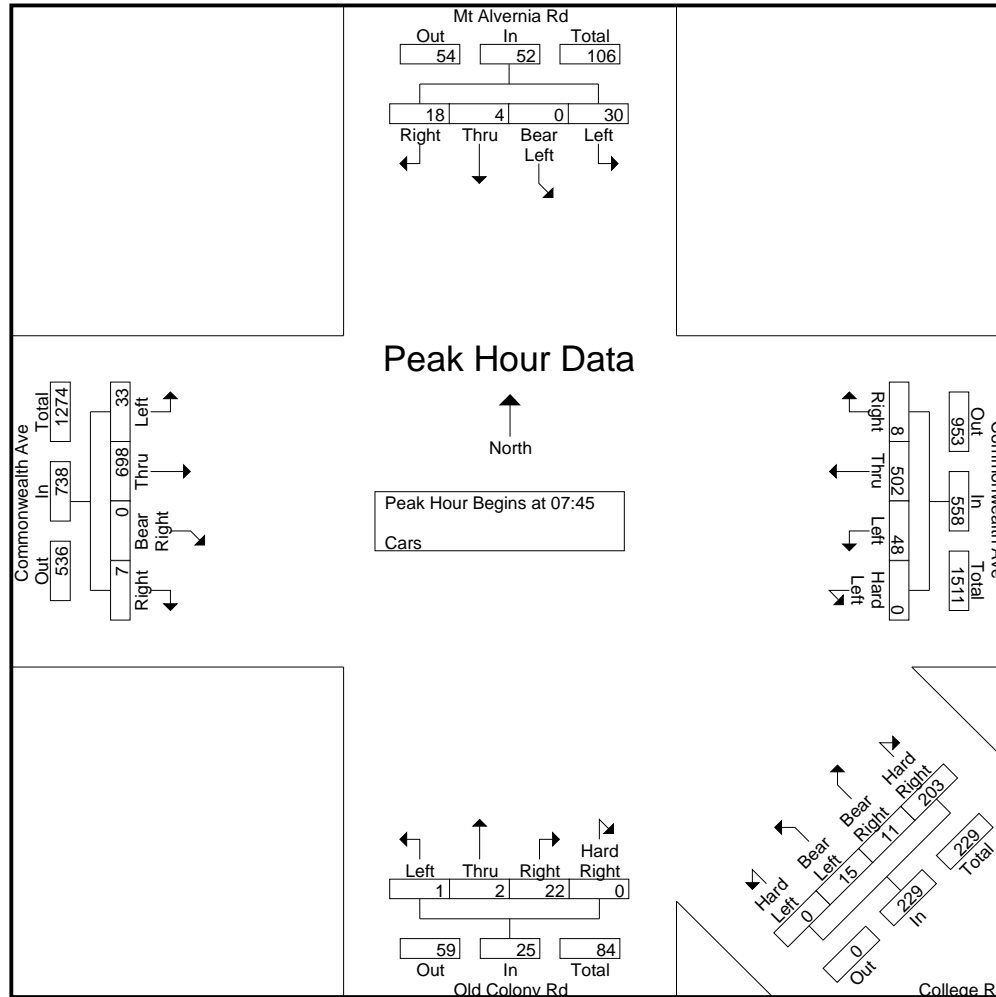

Peak Hour Analysis From 07:00 to 08:45 - Peak 1 of 1
Peak Hour for Each Approach Begins at:

F15	07:45					08:00					07:45					08:00					07:45				
+0 mins.	8	0	0	8	16	0	10	123	2	135	0	5	4	52	61	0	0	3	0	3	18	213	0	0	231
+15 mins.	5	0	0	3	8	0	15	129	0	144	0	3	2	47	52	0	0	5	0	5	5	165	0	5	175
+30 mins.	6	0	0	3	9	0	12	135	1	148	0	2	3	53	58	1	0	10	0	11	5	150	0	2	157
+45 mins.	11	0	4	4	19	0	17	137	0	154	0	5	2	51	58	4	1	32	0	37	5	170	0	0	175
Total Volume	30	0	4	18	52	0	54	524	3	581	0	15	11	203	229	5	1	50	0	56	33	698	0	7	738

Accurate Counts
978-664-2565

File Name : 39000004
Site Code : 39000004
Start Date : 3/11/2008
Page No : 3

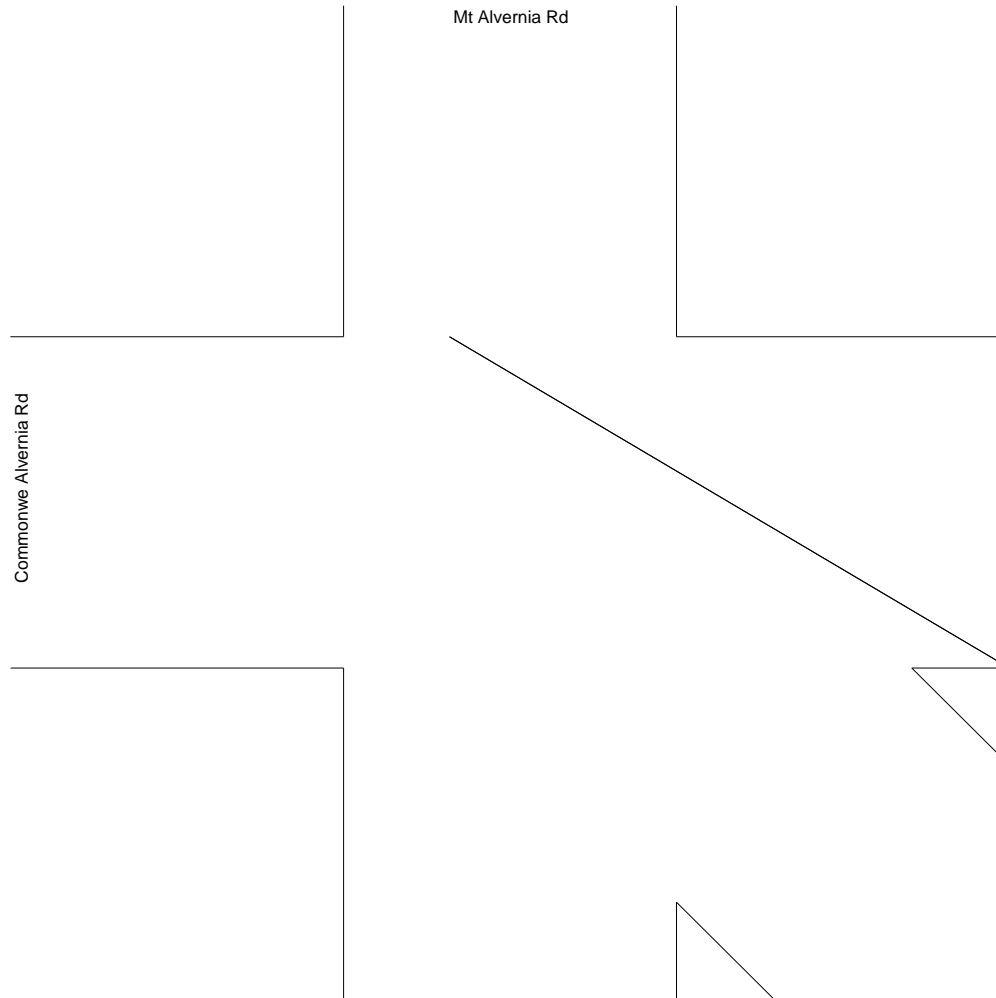

Accurate Counts
978-664-2565

File Name : 39000004
Site Code : 39000004
Start Date : 3/11/2008
Page No : 3

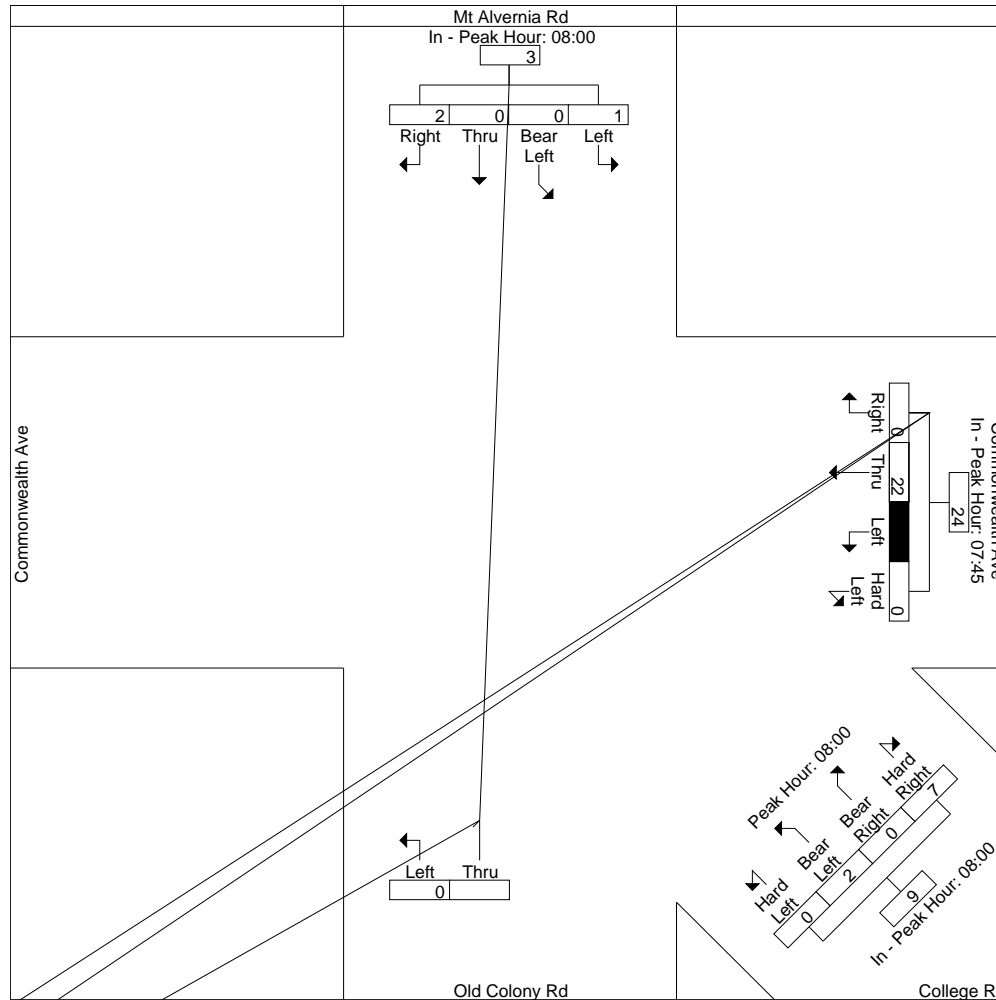

N/S Street : Old Colony Road
 E/W Street: Commonwealth Avenue
 City/State : Newton, MA
 Weather : Clear

Accurate Counts
 978-664-2565

File Name : 39000004
 Site Code : 39000004
 Start Date : 3/11/2008
 Page No : 1

Groups Printed- Cars - Trucks

	Mt Alvernia Rd From North					Commonwealth Ave From East		College Rd From Southeast		Old Colony Rd From South		Commonwealth Ave From West	
Start Time	Left	Bear Left	Thru	Right	Peds	Hard Left							

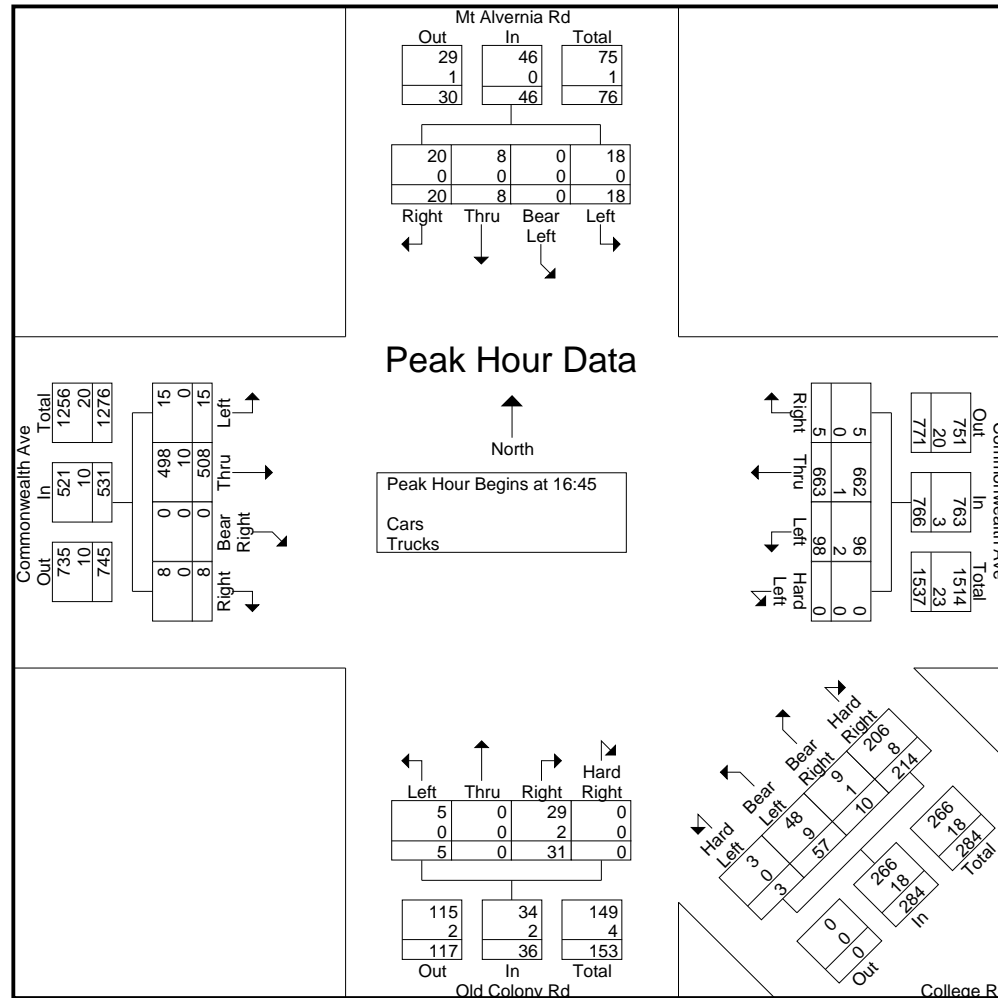

Peak Hour Analysis From 16:00 to 17:45 - Peak 1 of 1
Peak Hour for Each Approach Begins at:

	16:30					16:45					16:45					16:45									
+0 mins.	9	0	2	4	15	0	29	126	2	157	1	10	1	50	62	3	0	8	0	11	8	123	0	5	136
+15 mins.	10	0	3	4	17	0	21	192	0	213	0	18	3	56	77	2	0	7	0	9	3	105	0	1	109
+30 mins.	2	0	2	8	12	0	26	185	2	213	2	13	3	58	76	0	0	1	0	1	2	137	0	2	141
+45 mins.	2	0	0	1	3	0	22	160	1	183	0	16	3	50	69	0	0	15	0	15	2	143	0	0	145
Total Volume	23	0	7	17	47	0	98	663	5	766	3	57	10	214	284	5	0	31	0	ET	BT 63418.64569.76 69.18 S	BT 561.6 69 Td -8 T			

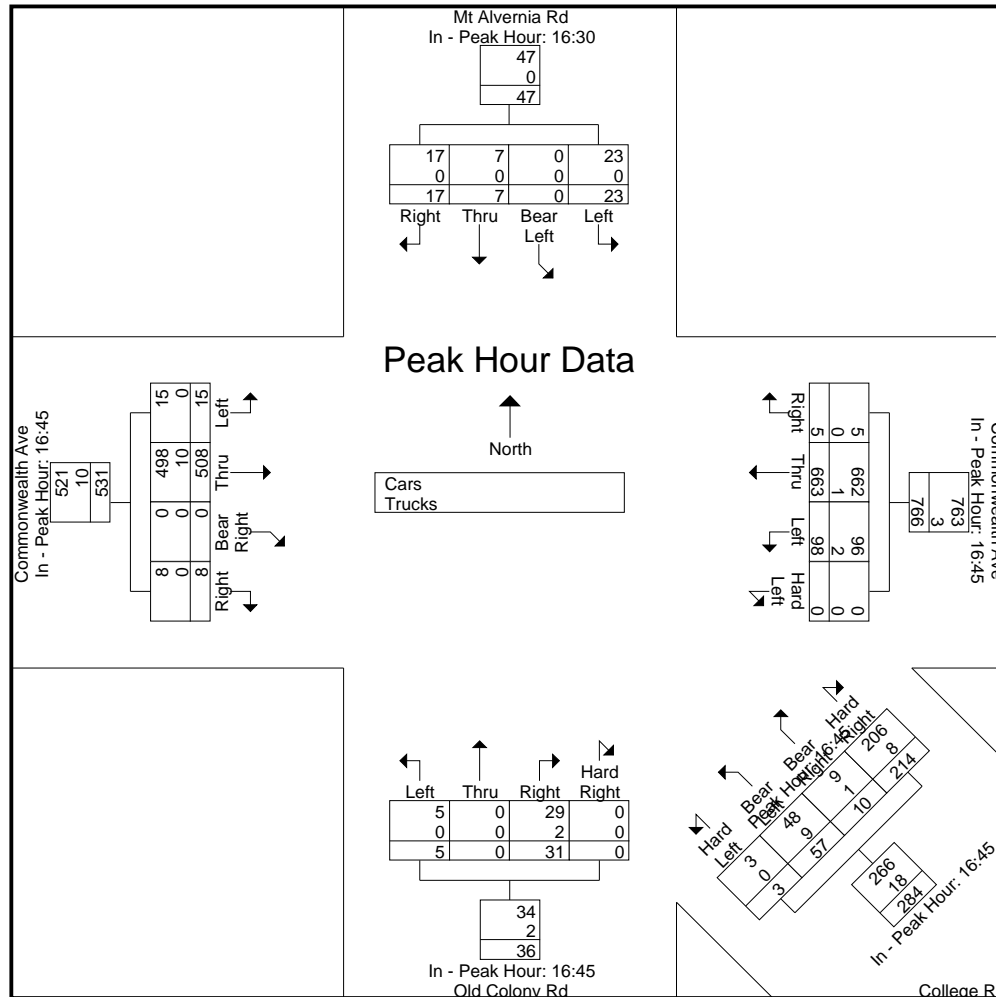

Accurate Counts
978-664-2565

File Name : 39000004
Site Code : 39000004
Start Date : 3/11/2008
Page No : 3

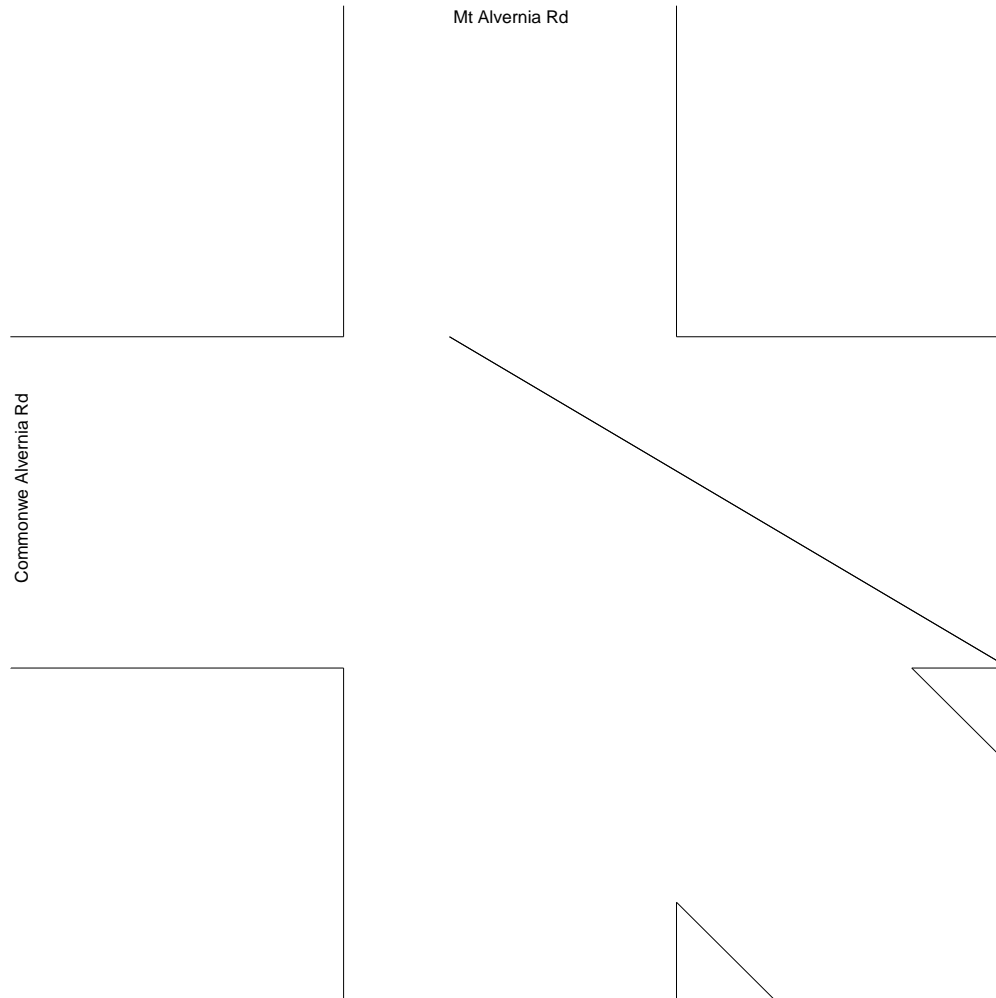

N/S Street : Old Colony Road
 E/W Street: Commonwealth Avenue
 City/State : Newton, MA
 Weather : Clear

Accurate Counts
 978-664-2565

File Name : 39000004
 Site Code : 39000004
 Start Date : 3/11/2008
 Page No : 1

Groups Printed- Trucks

Mt Alvernia Rd				Commonwealth Ave				College Rd				Old Colony Rd				Commonwealth Ave																				
From North				From East				From South				From South				From West																				
Start Time	Left	Thru		Start Time	Left	Thru		Start Time	Left	Thru		Start Time	Left	Thru		Start Time	Left	Thru																		
4.82	Td	-8	Ts (Thr	5.48	I	S		7.94	m	139	Td	165	From East	11	Ts (Bear Left)	9	Td	165	From South	7	Ts (From South)	96	S	Td	-8.27	From West	310.32	493.848	I	S	/ver	44	465.48	m	139	493.848

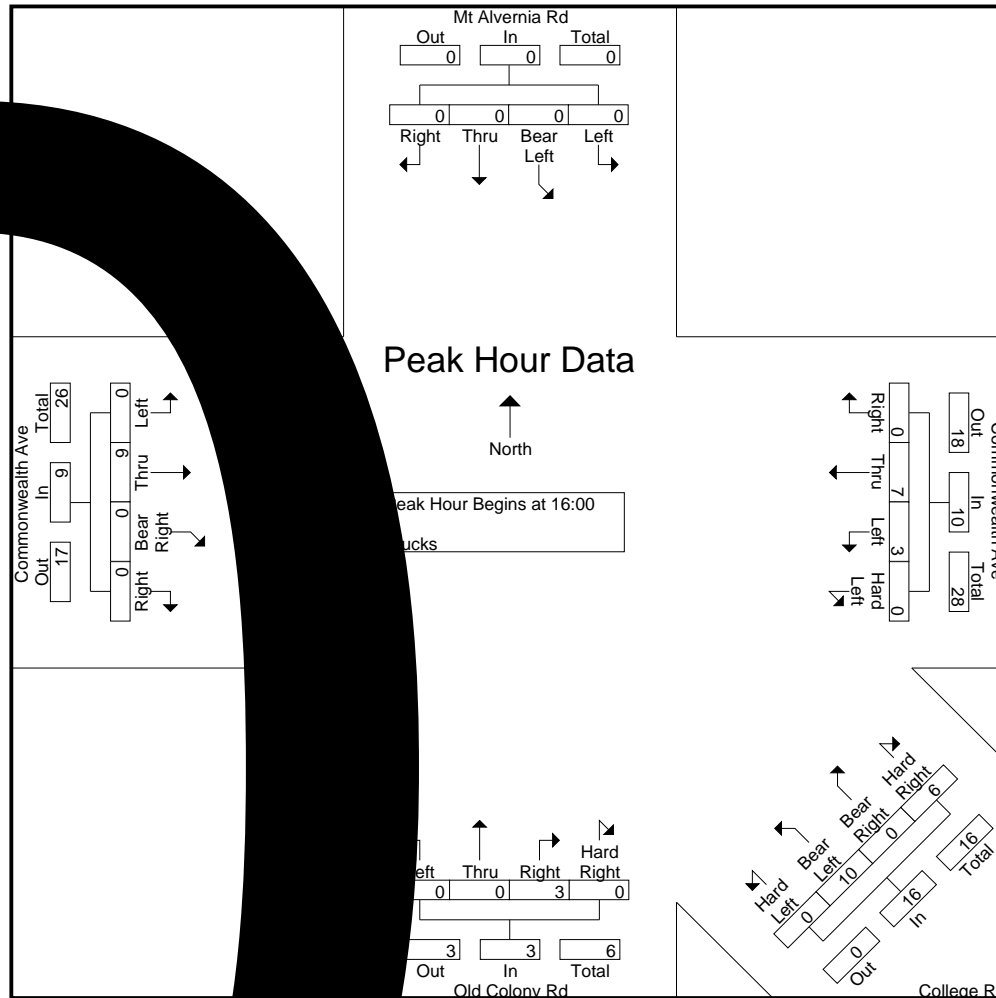

Peak Hour from 16:00 to 17:45 - Peak 1 of 1
Peak Hour Approach Begins at:

	15:45				16:00				16:30				16:00				16:15						
+0 min	0	0	0	0	0	2	2	0	0	5	0	2	7	0	0	2	0	2	0	2	0	0	2
+15 min	0	0	0	0	0	0	2	0	0	2	0	2	4	0	0	0	0	0	0	3	0	0	3
+30 min	0	0	0	0	0	0	2	0	0	2	0	1	3	0	0	1	0	1	0	2	0	0	2
+45 min	0	0	0	0	0	1	0	0	0	2	0	3	5	0	0	0	0	0	0	5	0	0	5
Total Volume	0	0	0	0	0	3	0	0	0	11	0	8	19	0	0	3	0	3	0	12	0	0	12
% App. Total																							

Accurate Counts
978-664-2565

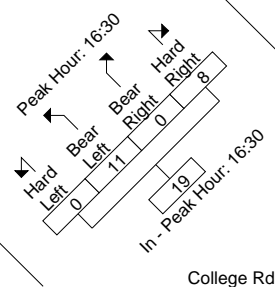
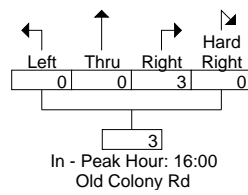
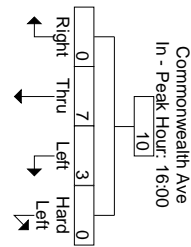
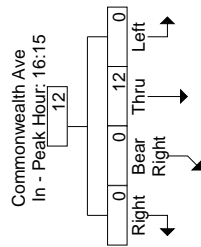
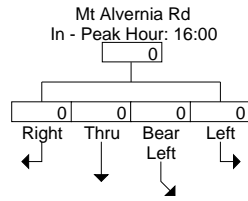

N/S Street : South Street
E/W Street: Commonwealth Avenue
City/State : Brighton, MA
Weather : Clear

Accurate Counts
978-664-2565

File Name : 39000005
Site Code : 39000005
Start Date : 3/11/2008
Page No : 1

Groups Printed- Cars - Trucks

	South St Left From North	Commonwealth Ave From East	Commonwealth Ave From West
Start Time	Left		

Accurate Counts
978-664-2565

File Name : 39000005
Site Code : 39000005
Start Date : 3/11/2008
Page No : 2

South St		
Out	In	Total
2	175	177
0	1	1
2	176	178

160	15
1	0
161	15
Right	Left

← →

Commonwealth Ave

Right



Commonwealth Ave

Accurate Counts
978-664-2565

File Name : 39000005
Site Code : 39000005
Start Date : 3/11/2008
Page No : 3

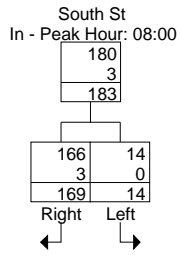

Commonwealth Ave

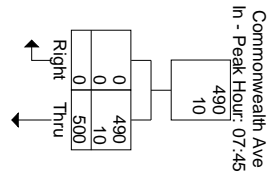

Accurate Counts
978-664-2565

File Name : 39000005
Site Code : 39000005
Start Date : 3/11/2008
Page No : 2

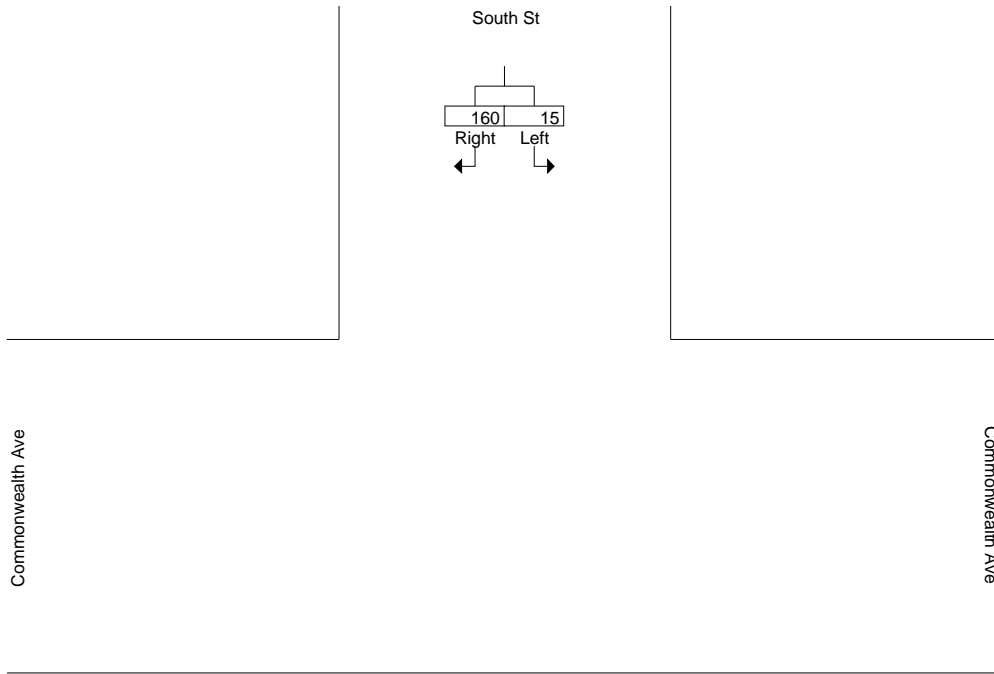

Accurate Counts
978-664-2565

File Name : 39000005
Site Code : 39000005
Start Date : 3/11/2008
Page No : 3

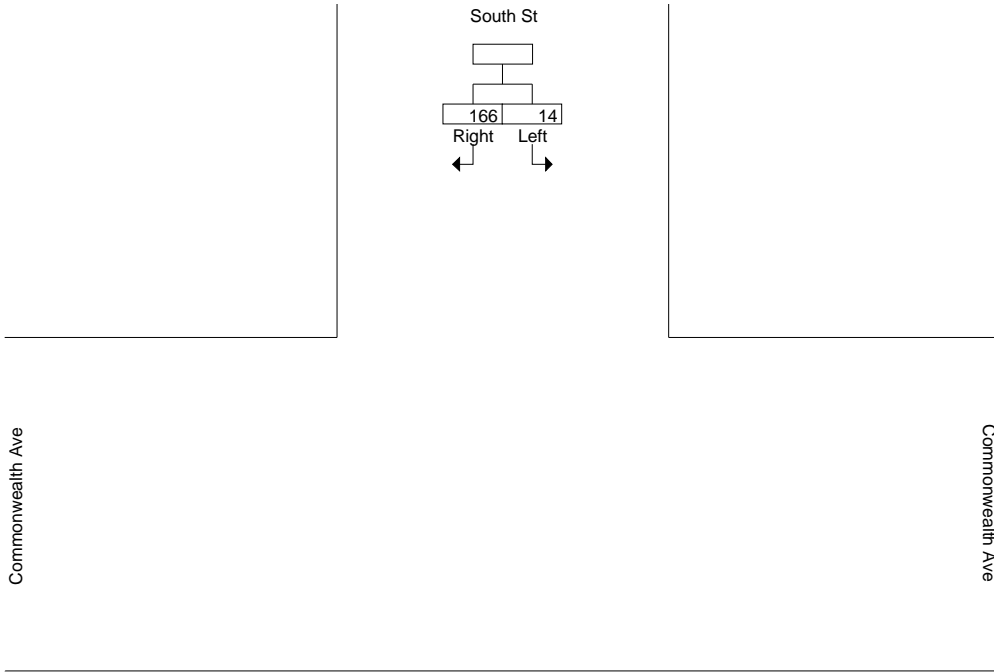

Accurate Counts
978-664-2565

File Name : 39000005
Site Code : 39000005
Start Date : 3/11/2008
Page No : 2

South St

Commonwealth Ave

Commonwealth Ave

N/S Street : South Street
E/W Street: Commonwealth Avenue
City/State : Brighton, MA
Weather : Clear

Accurate Counts
978-664-2565

File Name : 39000005
Site Code : 39000005
Start Date : 3/11/2008
Page No : 1

Groups Printed- Cars - Trucks

	South St From North	Commonwealth Ave From East	
--	------------------------	-------------------------------	--

Accurate Counts
978-664-2565

File Name : 39000005
Site Code : 39000005
Start Date : 3/11/2008
Page No : 2

South St		
Out	In	Total
1	179	180
0	1	1
1	180	181

152	27
1	0
153	27
Right	Left

← →

Commonwealth Ave

0	552
0	
0	
Right	Thru

← →

Commonwealth Ave

Accurate Counts
978-664-2565

File Name : 39000005
Site Code : 39000005
Start Date : 3/11/2008
Page No : 3

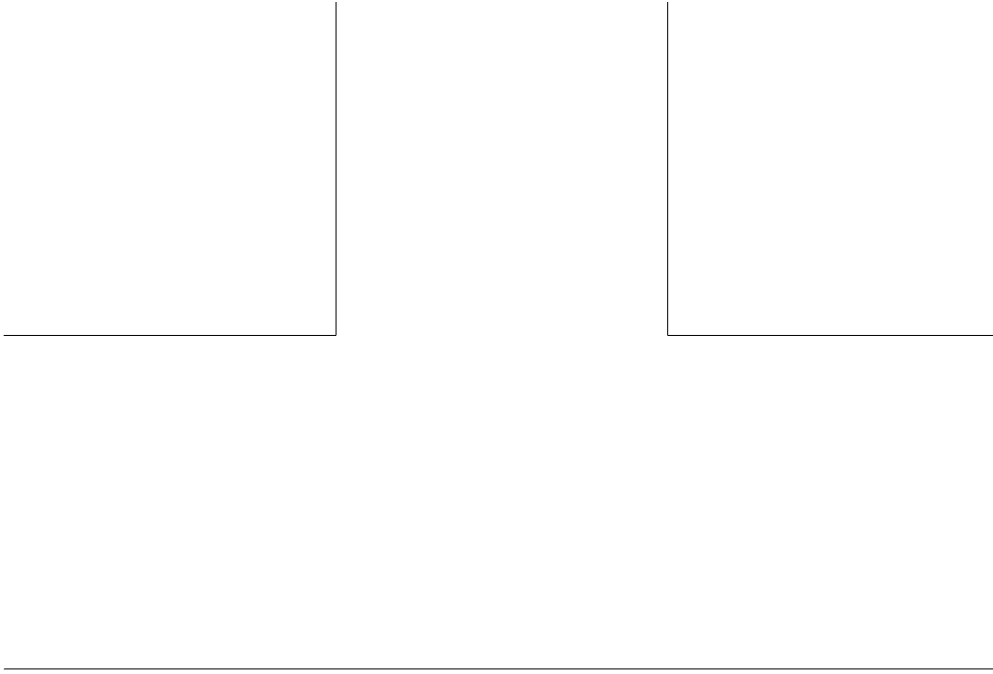

N/S Street : South Street
 E/W Street: Commonwealth Avenue
 City/State : Brighton, MA
 Weather : Clear

Accurate Counts
 978-664-2565

File Name : 39000005
 Site Code : 39000005
 Start Date : 3/11/2008
 Page No : 1

Groups Printed- Cars

Start Time	South St From North			Commonwealth Ave From East			Commonwealth Ave From West			Exclu. Total	Inclu. Total	Int. Total
	Left	Right	Peds	Thru	Right	Peds	Left	Thru	Peds			
16:00	5	30	4	105	0	7	0	103	3	14	243	257
16:15	5	52	1	119	0	12	0	113	12	25	289	314
16:30	5	43	4	89	0	4	0	133	11	19	270	289
16:45	2	41	0	112	0	5	0	145	8	13	300	313
Total	17	166	9	425	0	28	0	494	34	71	1102	1173
17:00	3	43	1	117	0	5	0	143	4	10	306	316
17:15	8	43	3	159	0	7	0	145	4	14	355	369
17:30	7	33	9	123	0	7	0	150	13	29	313	342
17:45	9	33	5	153	0	1	1	187	6	12	383	395
Total	27	152	18	552	0	20	1	625	27	65	1357	1422
Grand Total	44	318	27	977	0	48	1	1119	61	136	2459	2595
Apprch %	12.2	87.8		100	0		0.1	99.9				
Total %	1.8	12.9		39.7	0		0	45.5		5.2	94.8	

Start Time	South St From North			Commonwealth Ave From East			Commonwealth Ave From West			Int. Total
	Left	Right	App. Total	Thru	Right	App. Total	Left	Thru	App. Total	
17:00	3	43	46	117	0	117	0	143	143	306
17:15	8	43	51	159	0	159	0	145	145	355
17:30	7	33	40	123	0	123	0	150	150	313
17:45	9	33	42	153	0	153	1	187	188	383
Total Volume	27	152	179	552	0	552	1	625	626	1357
% App. Total	15.1	84.9		100	0		0.2	99.8		
PHF	.750	.884	.877	.868						

Peak Hour Analysis From 16:00 to 17:45 - Peak 1 of 1
 Peak Hour for Entire Intersection Begins at 17:00

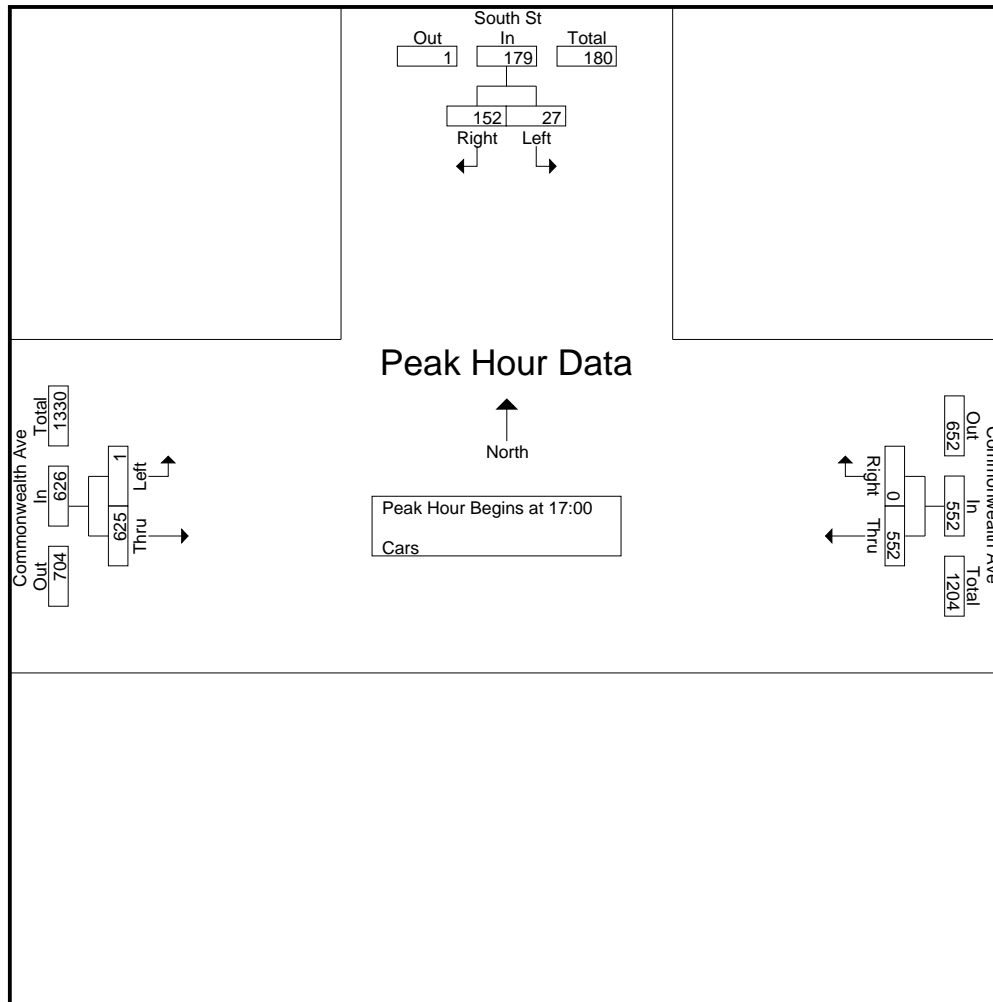

Peak Hour Analysis From 16:00 to 17:45 - Peak 1 of 1

Peak Hour for Each Approach Begins at:

	16:15			17:00			17:00		
+0 mins.	5	52	57	117	0	117	0	143	143
+15 mins.	5	43	48	159	0	159	0	145	145
+30 mins.	2	41	43	123	0	123	0	150	150
+45 mins.	3	43	46	153	0	153	1	187	188
Total Volume	15	179	194	552	0	552	1	625	626
% App. Total	7.7	92.3		100	0		0.2	99.8	
PHF	.750	.861	.851	.868	.000	.868	.250	.836	.832

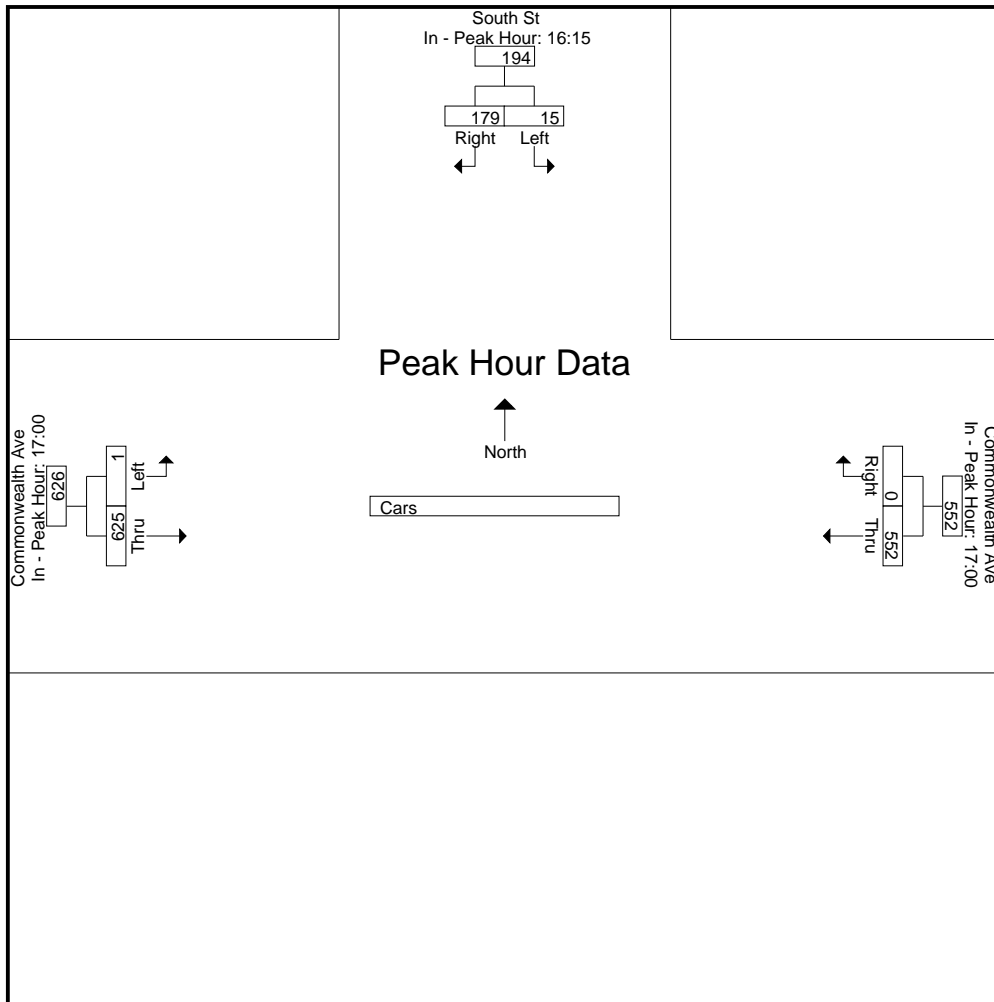

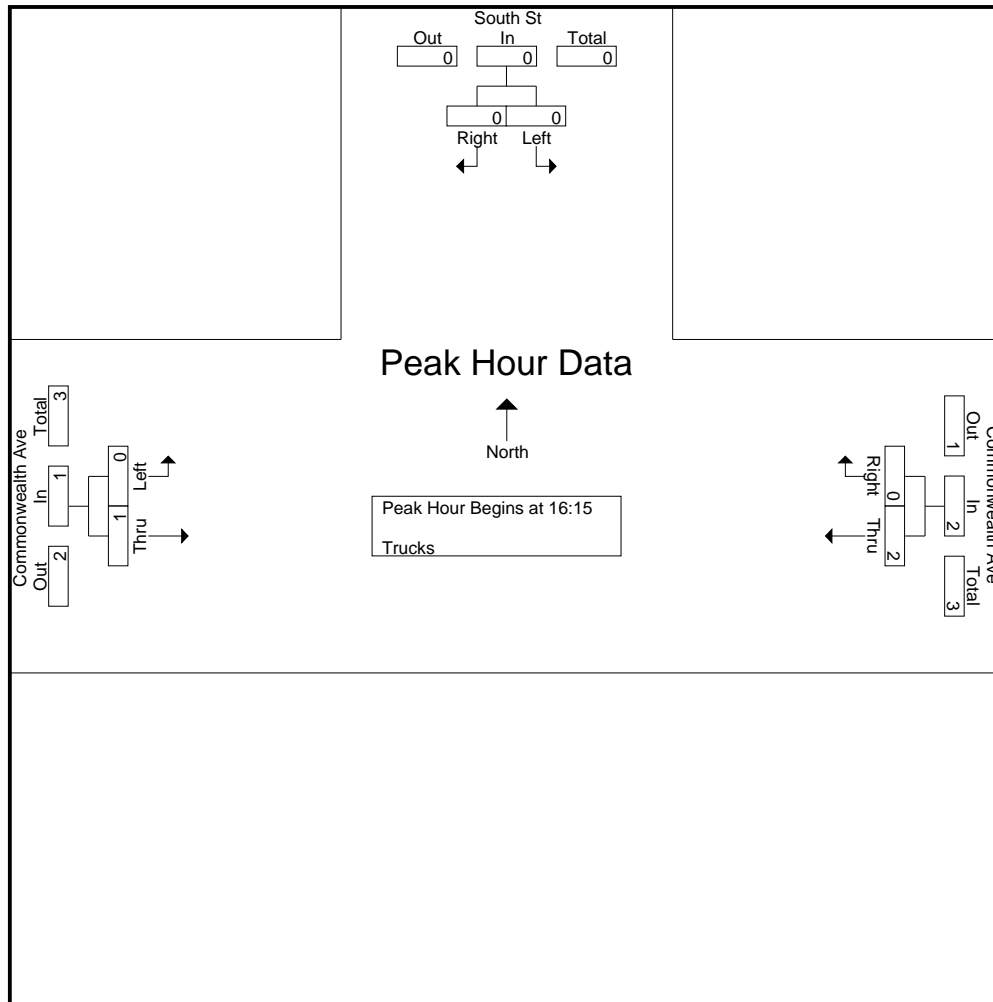

Peak Hour Analysis From 16:00 to 17:45 - Peak 1 of 1

Peak Hour for Each Approach Begins at:

	16:45			16:00			17:00		
+0 mins.	0	0	0	0	0	0	0	1	1
+15 mins.	0	0	0	0	0	0	0	0	0
+30 mins.	0	0	0	1	0	1	0	0	0
+45 mins.	0	1	1	1	0	1	0	1	1
Total Volume	0	1	1	2	0	2	0	2	2
% App. Total	0	100		100	0		0	100	
PHF	.000	.250	.250	.500	.000	.500	.000	.500	.500

Accurate Counts
978-664-2565

File Name : 39000005
Site Code : 39000005
Start Date : 3/11/2008
Page No : 3

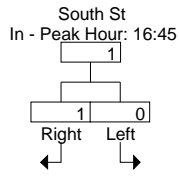

Commonwealth Ave

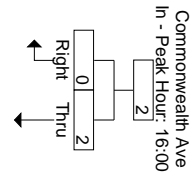
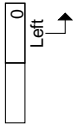

N/S Street : St. Thomas Moore Road
 E/W Street: Chestnut Hill Drive
 City/State : Brighton, MA
 Weather : Clear

Accurate Counts
 978-664-2565

File Name : 39000006
 Site Code : 39000006
 Start Date : 3/11/2008
 Page No : 1

Groups Printed- Cars - Trucks

Start Time	St Thomas Moore Rd From North			Chestnut Hill Dr From East			St Thomas Moore Rd From West			Exclu. Total	Inclu. Total	Int. Total
	Left	Right	Peds	Thru	Right	Peds	Left	Thru	Peds			
07:00	18	17	1	12	52	1	1	3	2	4	103	107
07:15	21	15	0	24	63	2	5	4	1	3	132	135
07:30	30	17	1	17	53	2	4	13	2	5	134	139
07:45	34	23	1	14	81	0	7	8	6	7	167	174
Total	103	72	3	67	249	5	17	28	11	19	536	555
08:00	26	22	3	17	46	0	8	25	4	7	144	151
08:15	29	35	2	35	62	2	4	16	6	10	181	191
08:30	31	42	4	39	66	15	4	14	1	20	196	216
08:45	46	44	4	87	58	1	9	15	4	9	259	268
Total	132	143	13	178	232	18	25	70	15	46	780	826
Grand Total	235	215	16	245	481	23	42	98	26	65	1316	1381
Apprch %	52.2	47.8		33.7	66.3		30	70				
Total %	17.9	16.3		18.6	36.6		3.2	7.4		4.7	95.3	
Cars	227	196		217	450		23	95		0	0	1273
% Cars	96.6	91.2	100	88.6	93.6	100	54.8	96.9	100	0	0	92.2
Trucks	8	19		28	31		19	3		0	0	108
% Trucks	3.4	8.8	0	11.4	6.4	0	45.2	3.1	0	0	0	7.8

Start Time	St Thomas Moore Rd From North			Chestnut Hill Dr From East			St Thomas Moore Rd From West			Int. Total
	Left	Right	App. Total	Thru	Right	App. Total	Left	Thru	App. Total	

Peak Hour Analysis From 07:00 to 08:45 - Peak 1 of 1
 Peak Hour for Entire Intersect

Accurate Counts
978-664-2565

File Name : 39000006
Site Code : 39000006
Start Date : 3/11/2008
Page No : 2

St Thomas Moore Rd



St Thomas Moore Rd

Chestnut Hill Dr

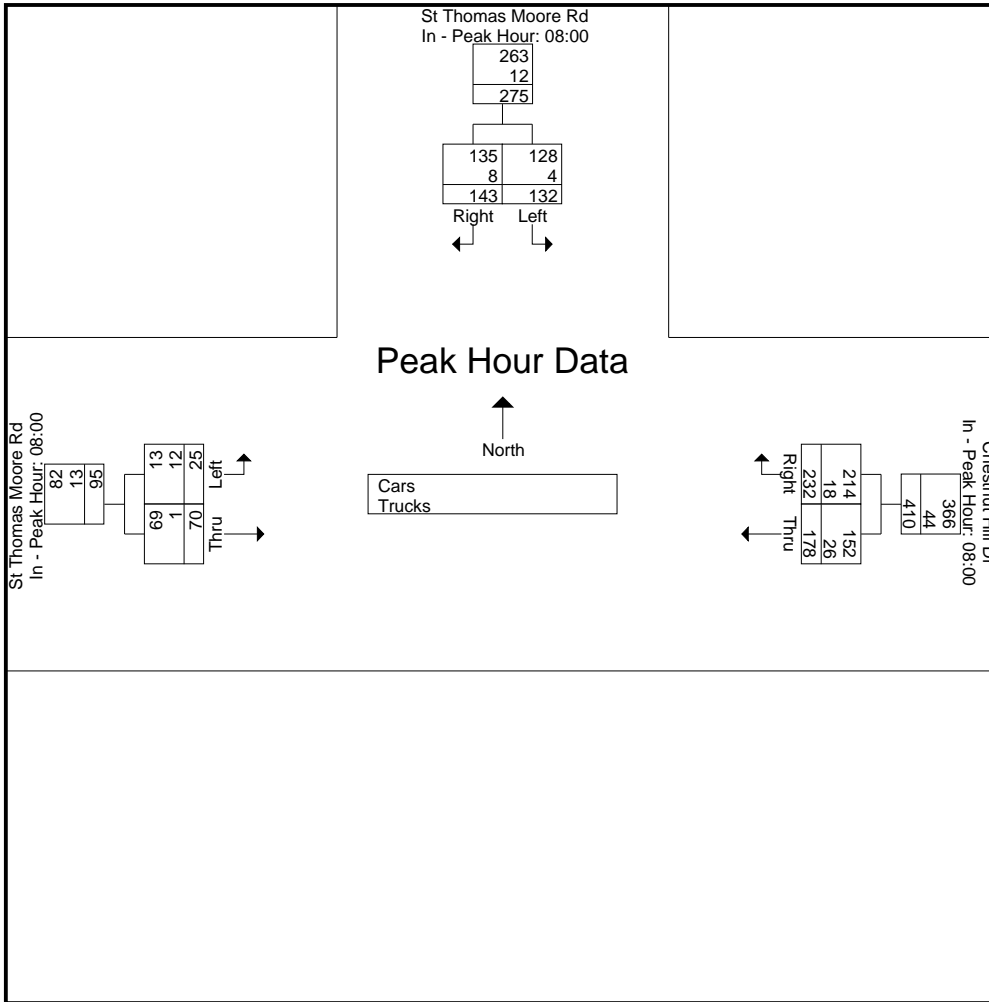

N/S Street : St. Thomas Moore Road
E/W Street: Chestnut Hill Drive
City/State : Brighton, MA
Weather : Clear

Accurate Counts
978-664-2565

File Name : 39000006
Site Code : 39000006
Start Date : 3/11/2008
Page No : 1

	St Thomas Moore Rd
--	--------------------

Groups Printed- Cars

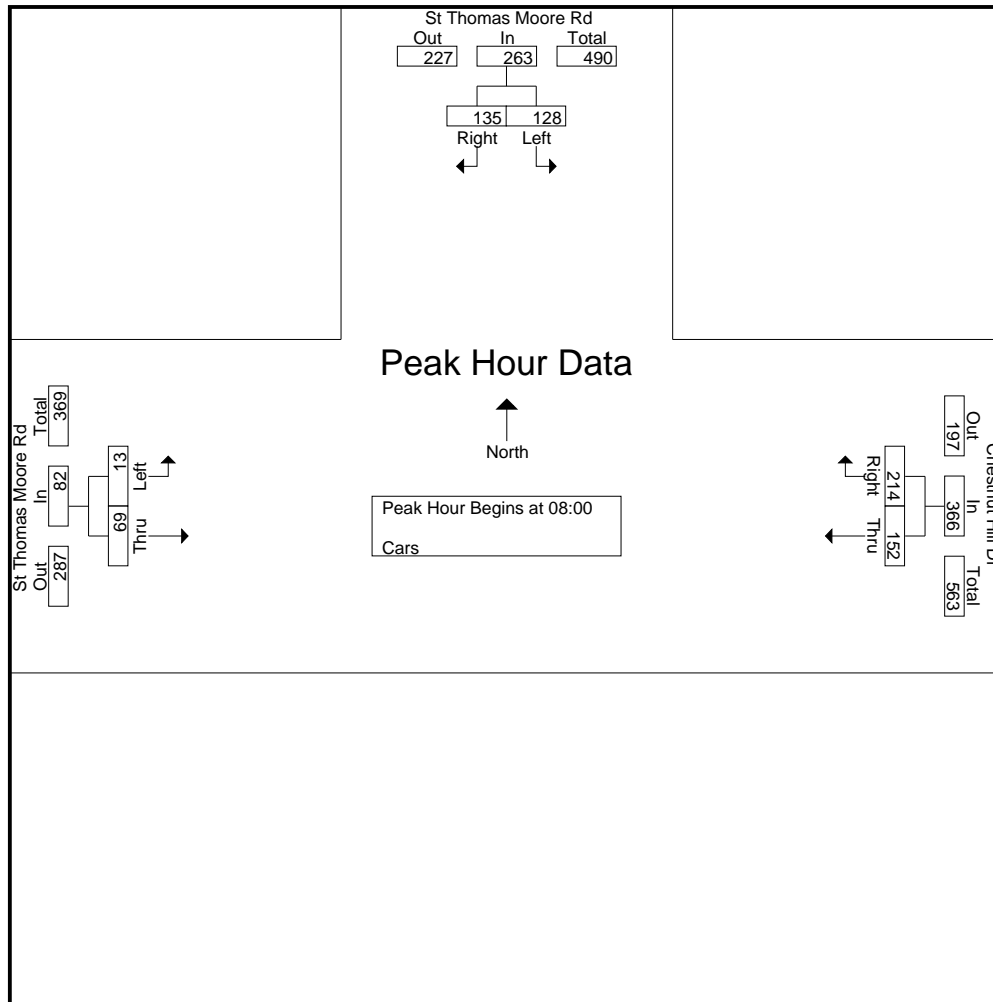

Peak Hour Analysis From 07:00 to 08:45 - Peak 1 of 1

Peak Hour for Each Approach Begins at:

	08:00			08:00			08:00		
+0 mins.	26	21	47	17	43	60	5	24	29
+15 mins.	27	32	59	33	59	92	1	16	17
+30 mins.	30	39	69	38	59	97	1	14	15
+45 mins.	45	43	88	64	53	117	6	15	21
Total Volume	128	135	263	152	214	366	13	69	82
% App. Total	48.7	51.3		41.5	58.5		15.9	84.1	
PHF	.711	.785	.747	.594	.907	.782	.542	.719	.707

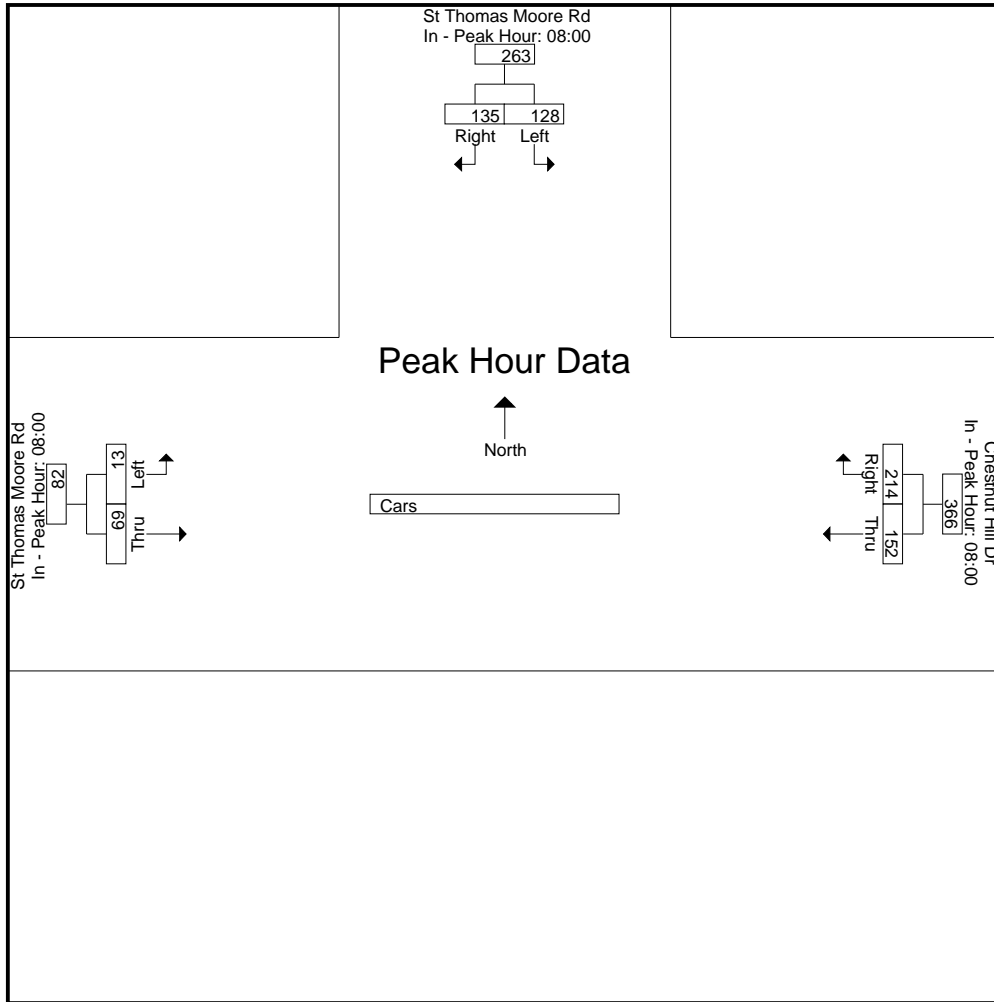

N/S Street : St. Thomas Moore Road
 E/W Street: Chestnut Hill Drive
 City/State : Brighton, MA
 Weather : Clear

Accurate Counts
 978-664-2565

File Name : 39000006
 Site Code : 39000006
 Start Date : 3/11/2008
 Page No : 1

Groups Printed- Trucks

Start Time	St Thomas Moore Rd From North			Chestnut Hill Dr From East			St Thomas Moore Rd From West			Exclu. Total	Inclu. Total	Int. Total
	Left	Right	Peds	Thru	Right	Peds	Left	Thru	Peds			
07:00	1	3	0	0	5	0	1	0	0	0	10	10
07:15	0	2	0	1	1	0	2	0	0	0	6	6
07:30	1	4	0	1	2	0	3	1	0	0	12	12
07:45	2	2	0	0	5	0	1	1	0	0	11	11
Total	4	11	0	2	13	0	7	2	0	0	39	39
08:00	0	1	0	0	3	0	3	1	0	0	8	8
08:15	2	3	0	2	3	0	3	0	0	0	13	13
08:30	1	3	0	1	7	0	3	0	0	0	15	15
08:45	1	1	0	23	5	0	3	0	0	0	33	33
Total	4	8	0	26	18	0	12	1	0	0	69	69
Grand Total	8	19	0	28	31	0	19	3	0	0	108	108
Apprch %	29.6	70.4		47.5	52.5		86.4	13.6				
Total %	7.4	17.6		25.9	28.7		17.6	2.8		0	100	

Start Time	St Thomas Moore Rd From North			Chestnut Hill Dr From East			St Thomas Moore Rd From West			Int. Total
	Left	Right	App. Total	Thru	Right	App. Total	Left	Thru	App. Total	

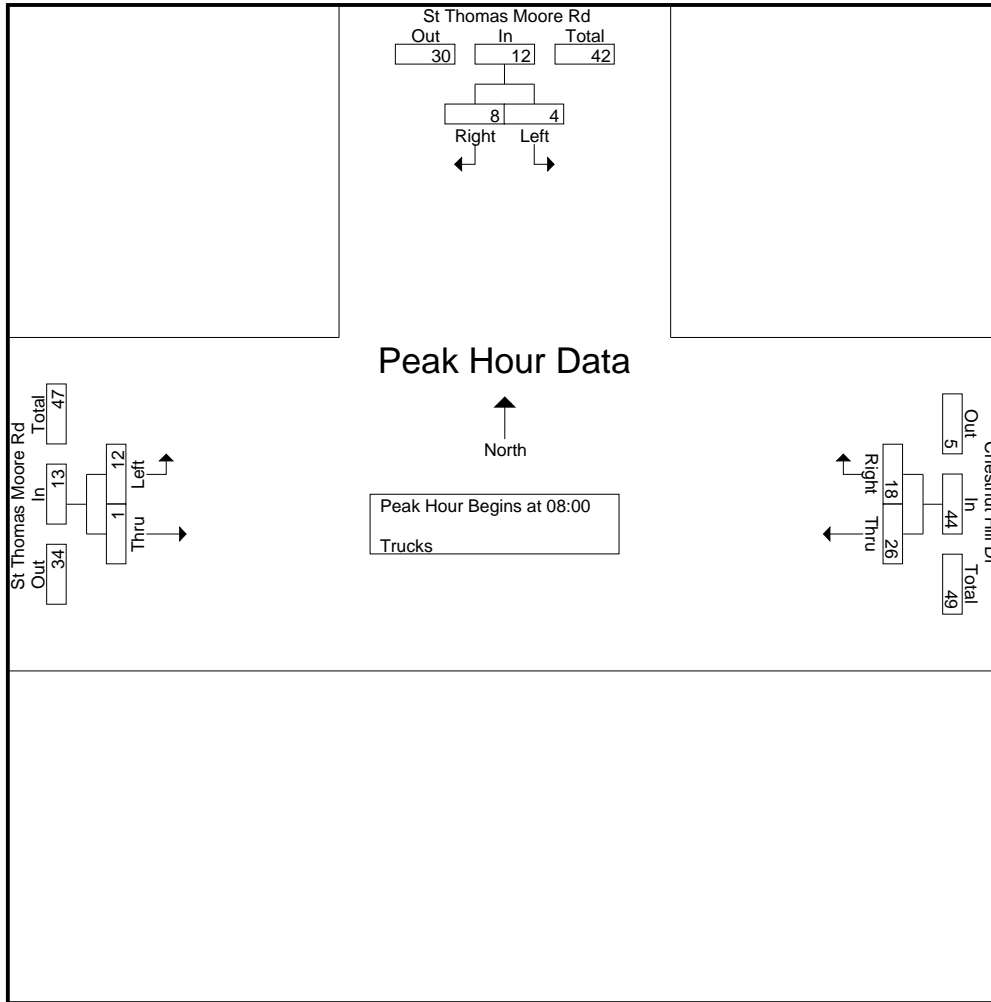

Peak Hour Analysis From 07:00 to 08:45 - Peak 1 of 1

Peak Hour for Each Approach Begins at:

	07:00			08:00			07:30		
+0 mins.	1	3	4	0	3	3	3	1	4
+15 mins.	0	2	2	2	3	5	1	1	2
+30 mins.	1	4	5	1	7	8	3	1	4
+45 mins.	2	2	4	23	5	28	3	0	3
Total Volume	4	11	15	26	18	44	10	3	13
% App. Total	26.7	73.3		59.1	40.9		76.9	23.1	
PHF	.500	.688	.750	.283	.643	.393	.833	.750	.813

Accurate Counts
978-664-2565

N/S Street : St. Thomas Moore Road
E/W Street: Chestnut Hill Drive
City/State : Brighton, MA
Weather : Clear

Accurate Counts
978-664-2565

File Name : 39000006
Site Code : 39000006
Start Date : 3/11/2008
Page No : 1

Groups Printed- Cars - Trucks

	St Thomas Moore Rd From North	Chestnut Hill Dr From East	St Thomas Moore Rd From West
Start Time	Left		

1135.4

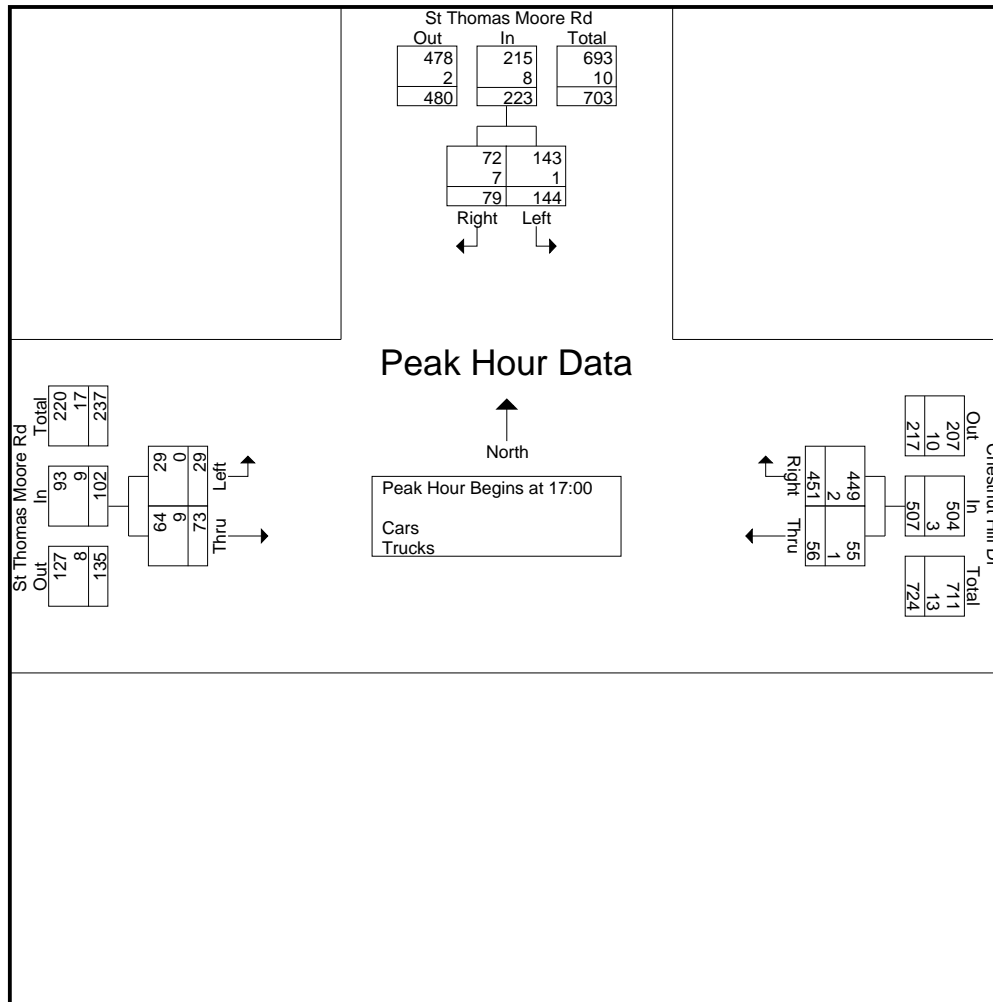

Peak Hour Analysis From 16:00 to 17:45 - Peak 1 of 1

Peak Hour for Each Approach Begins at:

	124	17:00	17:00	16:30					
+0 mins.	23	11	34	11	128	139	8	17	25
+15 mins.	36	25	61	11	108	119	8	11	19
+30 mins.	39	20	59	13	112	125	10	21	31
+45 mins.	46	23	69	21	103	124	8	19	27
Total Volume	144	79	223	56	451	507	34	68	102
% App. Total	64.6	35.4	8.29	68.28	21.9	35.4	1.1	6.74	3.57
PHF									

N/S Street : St. Thomas Moore Road
 E/W Street: Chestnut Hill Drive
 City/State : Brighton, MA
 Weather : Clear

Accurate Counts
 978-664-2565

File Name : 39000006
 Site Code : 39000006
 Start Date : 3/11/2008
 Page No : 1

Groups Printed- Cars

Start Time	St Thomas Moore Rd From North			Chestnut Hill Dr From East			St Thomas Moore Rd From West			Exclu. Total	Inclu. Total	Int. Total
	Left	Right	Peds	Thru	Right	Peds	Left	Thru	Peds			
16:00	39	15	5	26	125	14	4	16	10	29	225	254
16:15	30	26	5	21	101	27	4	18	11	43	200	243
16:30	30	13	6	14	82	19	8	15	18	43	162	205
16:45	27	14	6	13	89	23	8	9	11	40	160	200
Total	126	68	22	74	397	83	24	58	50	155	747	902
17:00	23	9	5	11	128	9	10	17	22	36	198	234
17:15	35	23	3	11	108	17	8	18	7	27	203	230
17:30	39	18	4	12	111	12	6	16	3	19	202	221
17:45	46	22	1	21	102	14	5	13	4	19	209	228
Total	143	72	13	55	449	52	29	64	36	101	812	913
Grand Total	269	140	35	129	846	135	53	122	86	256	1559	1815
Apprch %	65.8	34.2		13.2	86.8		30.3	69.7				
Total %	17.3	9		8.3	54.3		3.4	7.8		14.1	85.9	

Start Time	St Thomas Moore Rd From North			Chestnut Hill Dr From East			St Thomas Moore Rd From West			Int. Total
	Left	Right	App. Total	Thru	Right	App. Total	Left	Thru	App. Total	
Peak Hour Analysis From 16:00 to 17:45 - Peak 1 of 1										
Peak Hour for Entire Intersection Begins at 17:00										
17:00	23	9	32	11	128	139	10	17	27	198
17:15	35	23	58	11	108	119	8	18	26	203
17:30	39	18	57	12	111	123	6	16	22	202
17:45	46	22	68	21	102	123	5	13	18	209
Total Volume	143	72	215	55	449	504	29	64	93	812
% App. Total	66.5	33.5		10.9	89.1		31.2	68.8		
PHF	.777	.783	.790	.655	.877	.906	.725	.889	.861	.971

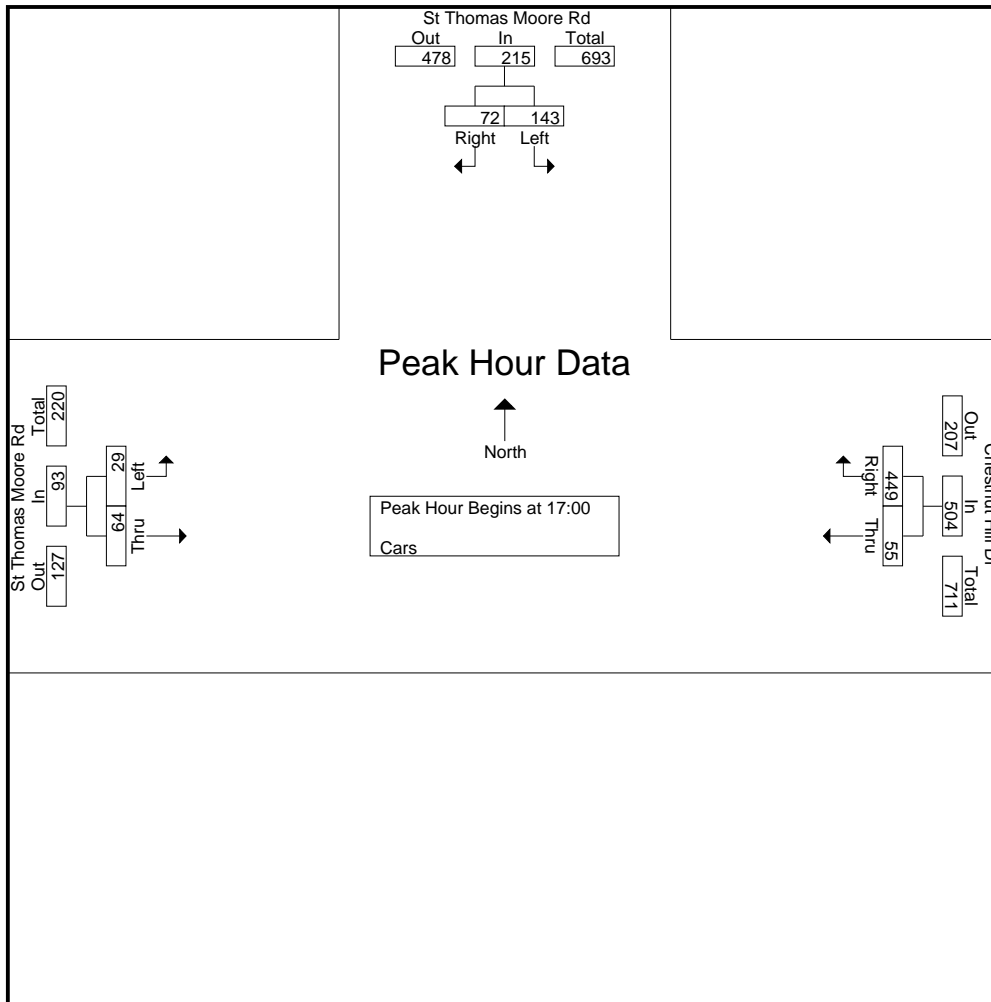

Peak Hour Analysis From 16:00 to 17:45 - Peak 1 of 1

Peak Hour for Each Approach Begins at:

17:00

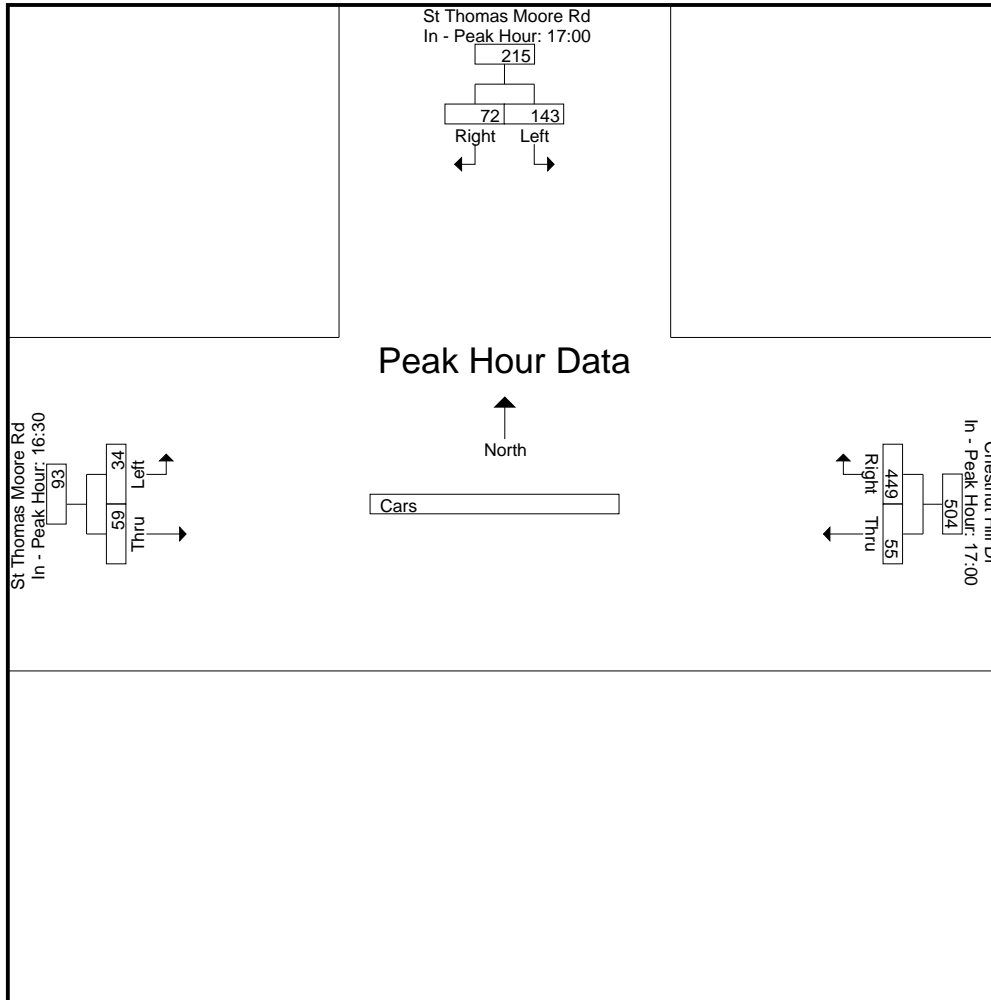

N/S Street : St. Thomas Moore Road
 E/W Street: Chestnut Hill Drive
 City/State : Brighton, MA
 Weather : Clear

Accurate Counts
 978-664-2565

File Name : 39000006
 Site Code : 39000006
 Start Date : 3/11/2008
 Page No : 1

Groups Printed- Trucks

Start Time	St Thomas Moore Rd From North			Chestnut Hill Dr From East			St Thomas Moore Rd From West			Exclu. Total	Inclu. Total	Int. Total
	Left	Right	Peds	Thru	Right	Peds	Left	Thru	Peds			
16:00	0	2	0	1	0	0	0	3	0	0	6	6
16:15	0	2	0	0	0	0	0	2	0	0	4	4
16:30	2	2	0	1	1	0	0	2	0	0	8	8
16:45	0	2	0	1	0	0	0	2	0	0	5	5
Total	2	8	0	3	1	0	0	9	0	0	23	23
17:00	0	2	0	0	0	0	0	4	0	0	6	6
17:15	1	2	0	0	0	0	0	1	0	0	4	4
17:30	0	2	0	1	1	0	0	2	0	0	6	6
17:45	0	1	0	0	1	0	0	2	0	0	4	4
Total	1	7	0	1	2	0	0	9	0	0	20	20
Grand Total	3	15	0	4	3	0	0	18	0	0	43	43
Apprch %	16.7	83.3		57.1	42.9		0	100				
Total %	7	34.9		9.3	7		0	41.9		0	100	

Start Time	St Thomas Moore Rd From North			Chestnut Hill Dr From East			St Thomas Moore Rd From West			Int. Total
	Left	Right	App. Total	Thru	Right	App. Total	Left	Thru	App. Total	
Peak Hour Analysis From 16:00 to 17:45 - Peak 1 of 1										
Peak Hour for Entire Intersection Begins at 16:00										
16:00	0	2	2	1	0	1	0	3	3	6
16:15	0	2	2	0	0	0	0	2	2	4
16:30	2	2	4	1	1	2	0	2	2	8
16:45	0	2	2	1	0	1	0	2	2	5
Total Volume	2	8	10	3	1	4	0	9	9	23
% App. Total	20	80		75	25		0	100		
PHF	.250	1.000	.625	.750	.250	.500	.000	.750	.750	.719

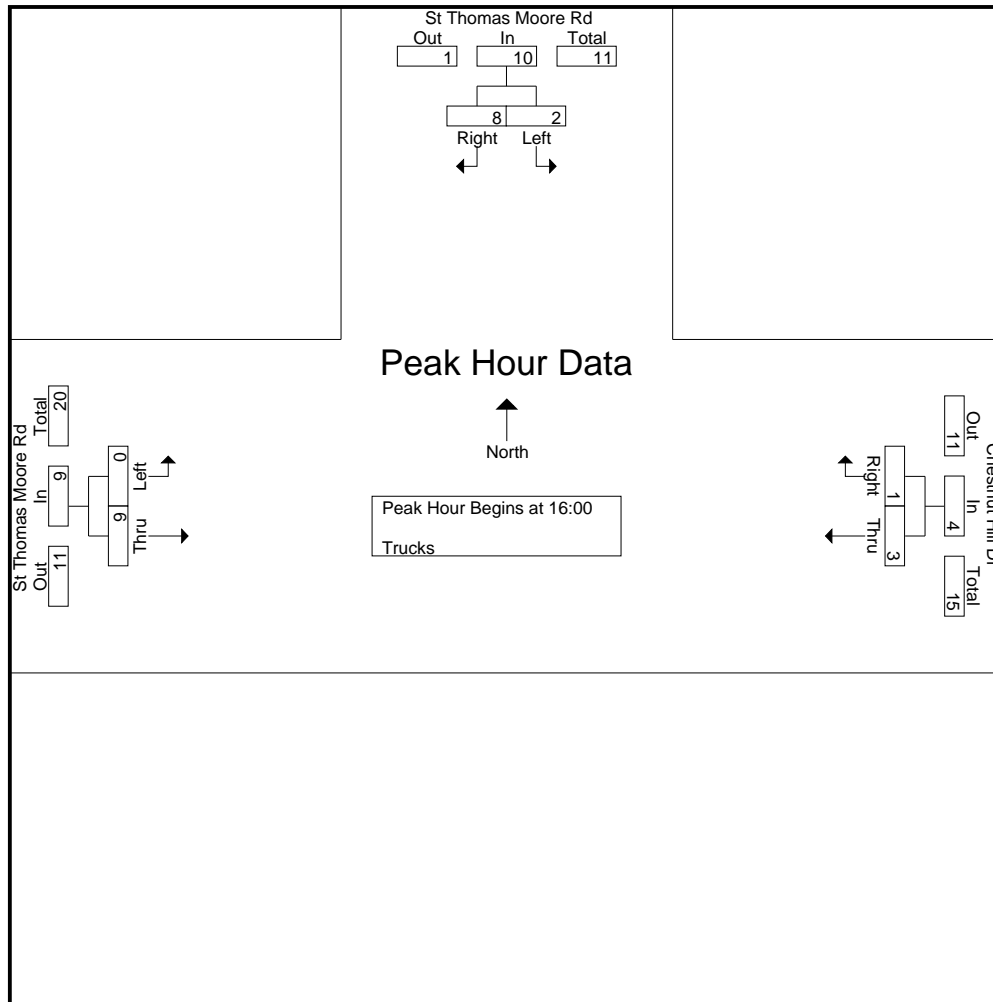

Peak Hour Analysis From 16:00 to 17:45 - Peak 1 of 1

Peak Hour for Each Approach Begins at:

	16:30			16:00			16:15		
+0 mins.	2	2	4	1	0	1	0	2	2
+15 mins.	0	2	2	0	0	0	0	2	2
+30 mins.	0	2	2	1	1	2	0	2	2
+45 mins.	1	2	3	1	0	1	0	4	4
Total Volume	3	8	11	3	1	4	0	10	10
% App. Total	27.3	72.7		75	25		0	100	
PHF	.375	1.000	.688	.750	.250	.500	.000	.625	.625

Accurate Counts
978-664-2565

N/S Street : Hammond Street
 E/W Street: Beacon Street
 City/State : Newton, MA
 Weather : Clear

Accurate Counts
 978-664-2565

File Name : 39000007
 Site Code : 39000007
 Start Date : 3/11/2008
 Page No : 1

Groups Printed- Cars - Trucks

Start Time	Hammond St From North				College Rd From Northeast					Beacon St From East				Hammond St From South				Beacon St From West					
	Hard Left	Left	Thru	Right	Peds	Hard Left	Bear Left	Bear Right	Hard Right	Peds	Left	Thru	Right	Hard Right	Peds	Left	Thru	Bear Right	Right	Peds	Left	Bear Left	Thru

Accurate Counts
978-664-2565

File Name : 39000007
Site Code : 39000007
Start Date : 3/11/2008
Page No : 2

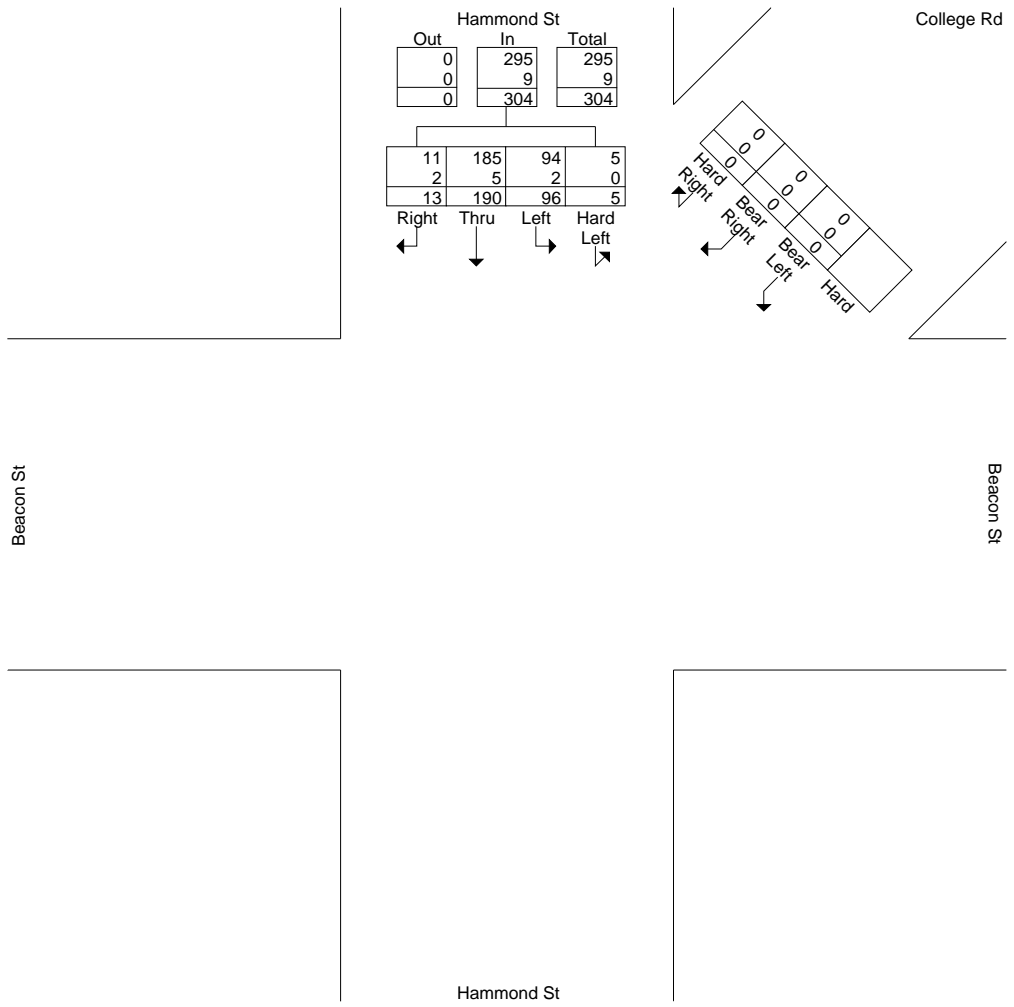

Accurate Counts
978-664-2565

N/S Street : Hammond Street
 E/W Street: Beacon Street
 City/State : Newton, MA
 Weather : Clear

Accurate Counts
 978-664-2565

File Name : 39000007
 Site Code : 39000007
 Start Date : 3/11/2008
 Page No : 1

Groups Printed- Cars

Start Time	Hammond St From North					College Rd From Northeast					Beacon St From East					Hammond St From South					Beacon St From West					Exclu. Total	Inclu. Total	Int. Total
	Hard Left	Left	Thru	Right	Peds	Hard Left	Bear Left	Bear Right	Hard Right	Peds	Left	Thru	Right	Hard Right	Peds	Left	Thru	Bear Right	Right	Peds	Left	Bear Left	Thru	Right	Peds			
07:00	0	10	23	2	11	0	0	0	0	7	20	53	0	1	4	4	0	16	10	0	0	31	81	4	0	22	255	277
07:15	0	12	39	3	12	0	0	0	0	14	28	92	0	1	4	16	0	25	6	0	0	28	105	16	0	30	371	401
07:30	0	20	50	5	9	0	0	0	0	12	60	95	0	4	6	26	0	22	6	0	0	23	130	20	0	27	461	488
07:45	2	26	60	1	5	0	0	0	0	6	56	93	0	3	1	28	0	35	18	4	0	38	166	23	0	16	549	565
Total	2	68	172	11	37	0	0	0	0	39	164	333	0	9	15	74	0	98	40	4	0	120	482	63	0	95	1636	1731
08:00	1	20	45	5	9	0	0	0	0	21	40	104	0	6	5	34	0	28	18	2	0	37	181	23	0	37	542	579
08:15	1	18	37	2	22	0	0	0	0	65	49	140	0	6	10	30	0	24	9	1	0	26	173	18	0	98	533	631
08:30	1	30	43	3	93	0	0	0	0	250	44	106	0	14	5	16	0	28	24	1	0	36	170	13	1	350	528	878
08:45	1	20	36	4	171	0	0	0	0	500	40	94	0	12	18	18	0	29	20	0	0	36	138	9	0	689	457	1146
Total	4	88	161	14	295	0	0	0	0	836	173	444	0	38	38	98	0	109	71	4	0	135	662	63	1	1174	2060	3234
Grand Total	6	156	333	25	332	0	0	0	0	875	337	777	0	47	53	172	0	207	111	8	0	255	1144	126	1	1269	3696	4965
Apprch %	1.2	30	64	4.8		0	0	0	0		29	66.9	0	4		35.1	0	42.2	22.7		0	16.7	75	8.3				
Total %	0.2	4.2	9	0.7		0	0	0	0		9.1	21	0	1.3		4.7	0	5.6	3		0	6.9	31	3.4		25.6	74.4	

Start Time	Hammond St From North					College Rd From Northeast					Beacon St From East					Hammond St From South					Beacon St From West					Int. Total	
	Hard Left	Left	Thru	Right	App. Total	Hard Left	Bear Left	Bear Right	Hard Right	App. Total	Left	Thru	Right	Hard Right	App. Total	Left	Thru	Bear Right	Right	App. Total	Left	Bear Left	Thru	Right	App. Total		
Peak Hour Analysis From 07:00 to 08:45 - Peak 1 of 1																											
Peak Hour for Entire Intersection Begins at 07:45																											
07:45	2	26	60	1	89	0	0	0	0	0	56	93	0	3	152	28	0	35	18	81	0	38	166	23	227	549	
08:00	1	20	45	5	71	0	0	0	0	0	40	104	0	6	150	34	0	28	18	80	0	37	181	23	241	542	
08:15	1	18	37	2	58	0	0	0	0	0	49	140	0	6	195	30	0	24	9	63	0	67	173	18	127	332	
08300	1		43			0	0	0	0	0	49	106	0			10	0	28	49	664	0		170	23	197	528	

Accurate Counts
978-664-2565

File Name : 39000007
Site Code : 39000007
Start Date : 3/11/2008
Page No : 2

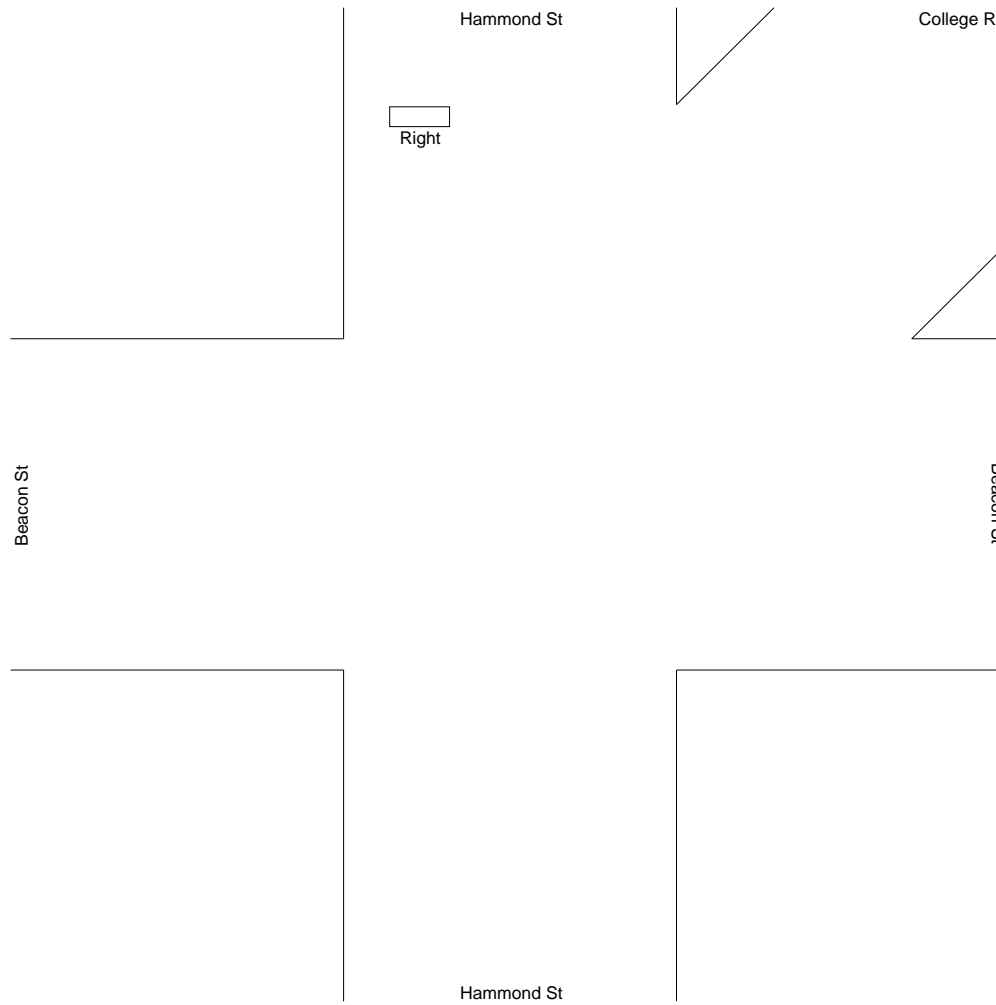

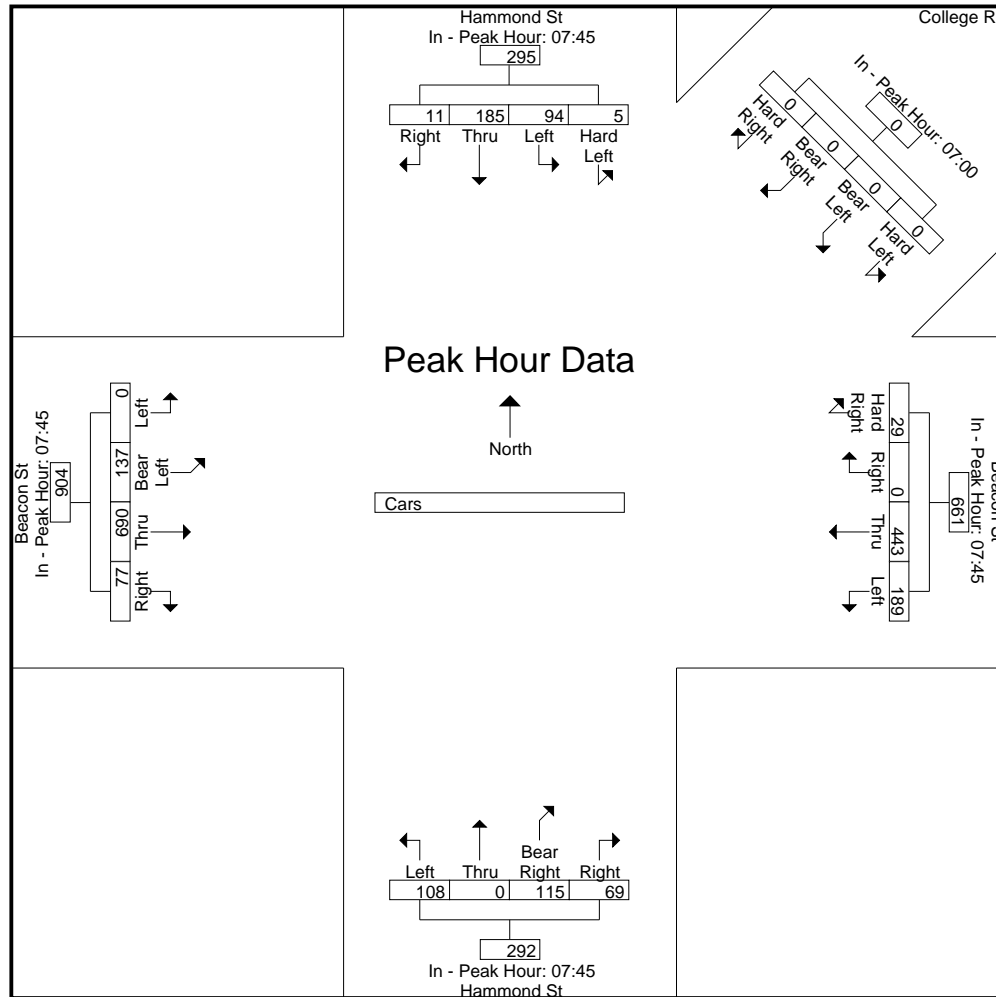

Accurate Counts
978-664-2565

File Name : 39000007
Site Code : 39000007
Start Date : 3/11/2008
Page No

Accurate Counts
978-664-2565

File Name : 39000007
Site Code : 39000007
Start Date : 3/11/2008
Page No : 2

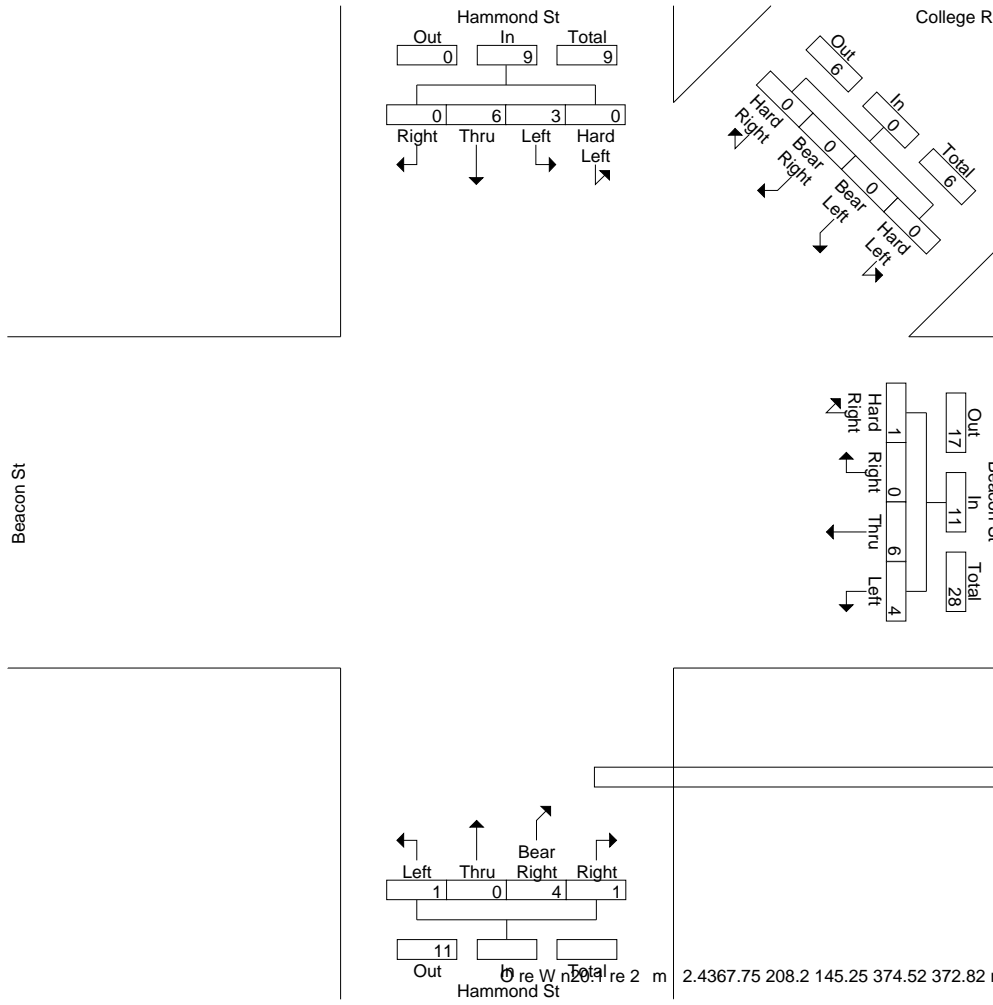

2.4367.75 208.2 145.25 374.52 372.82 re

Accurate Counts
978-664-2565

File Name : 39000007
Site Code : 39000007
Start Date : 3/11/2008
Page No : 3

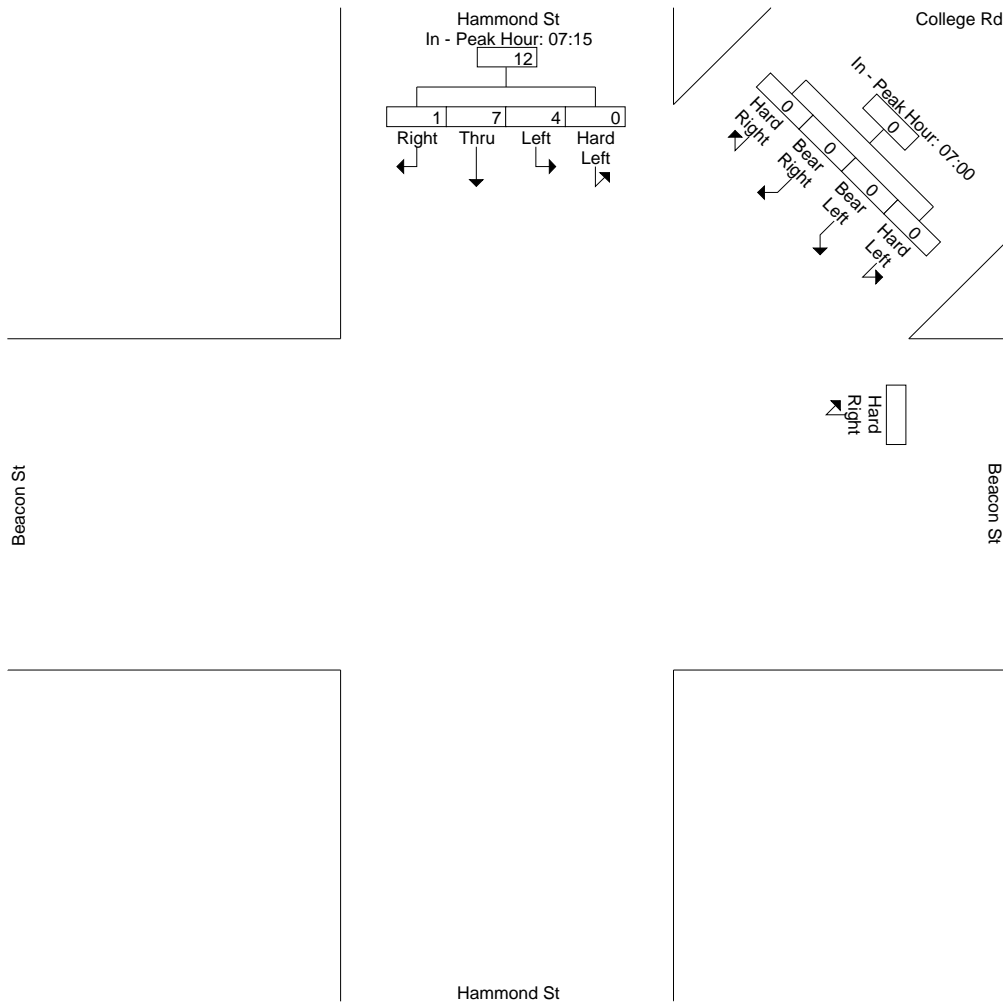

N/S Street : Hammond Street
E/W Street: Beacon Street
City/State : Newton, MA
Weather : Clear

Accurate Counts
978-664-2565

File Name : 39000007
Site Code : 39000007
Start Date : 3/11/2008
Page No : 1

Groups Printed- Cars - Trucks

--	--

Accurate Counts
978-664-2565

N/S Street : Hammond Street
E/W Street: Beacon Street
City/State : Newton, MA

Accurate Counts
978-664-2565

File Name : 39000007
Site Code : 39000007
Start Date : 3/11/2008
Page No : 1

Accurate Counts
978-664-2565

File Name : 39000007
Site Code : 39000007
Start Date : 3/11/2008
Page No : 2

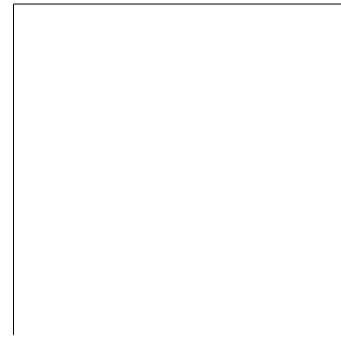
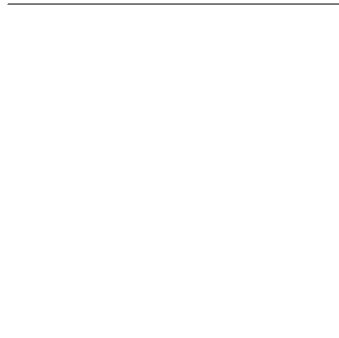
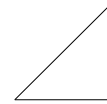
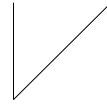
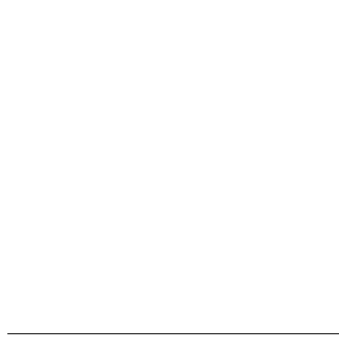

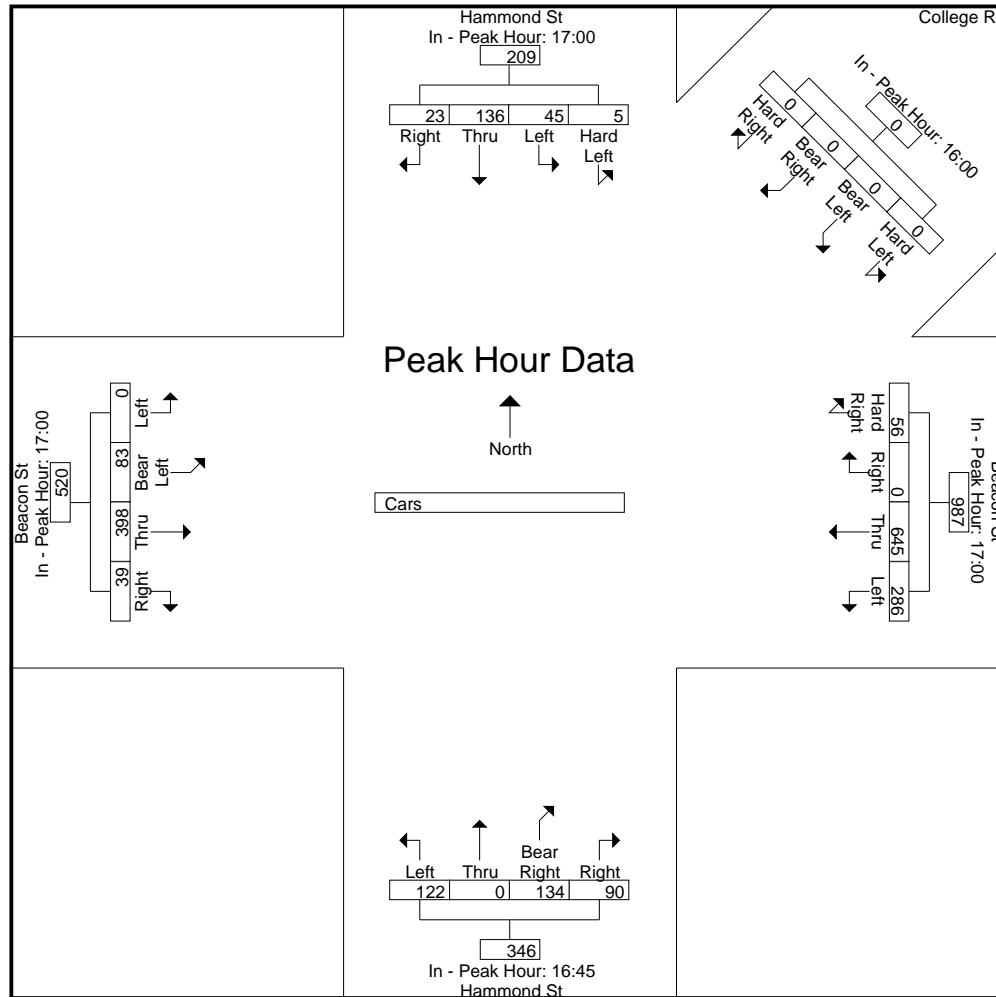

N/S Street : Hammond Street

Accurate Counts
978-664-2565

File Name : 39000007
Site Code : 39000007
Start Date : 3/11/2008
Page No : 1

Accurate Counts
978-664-2565

File Name : 39000007
Site Code : 39000007
Start Date : 3/11/2008
Page No : 2

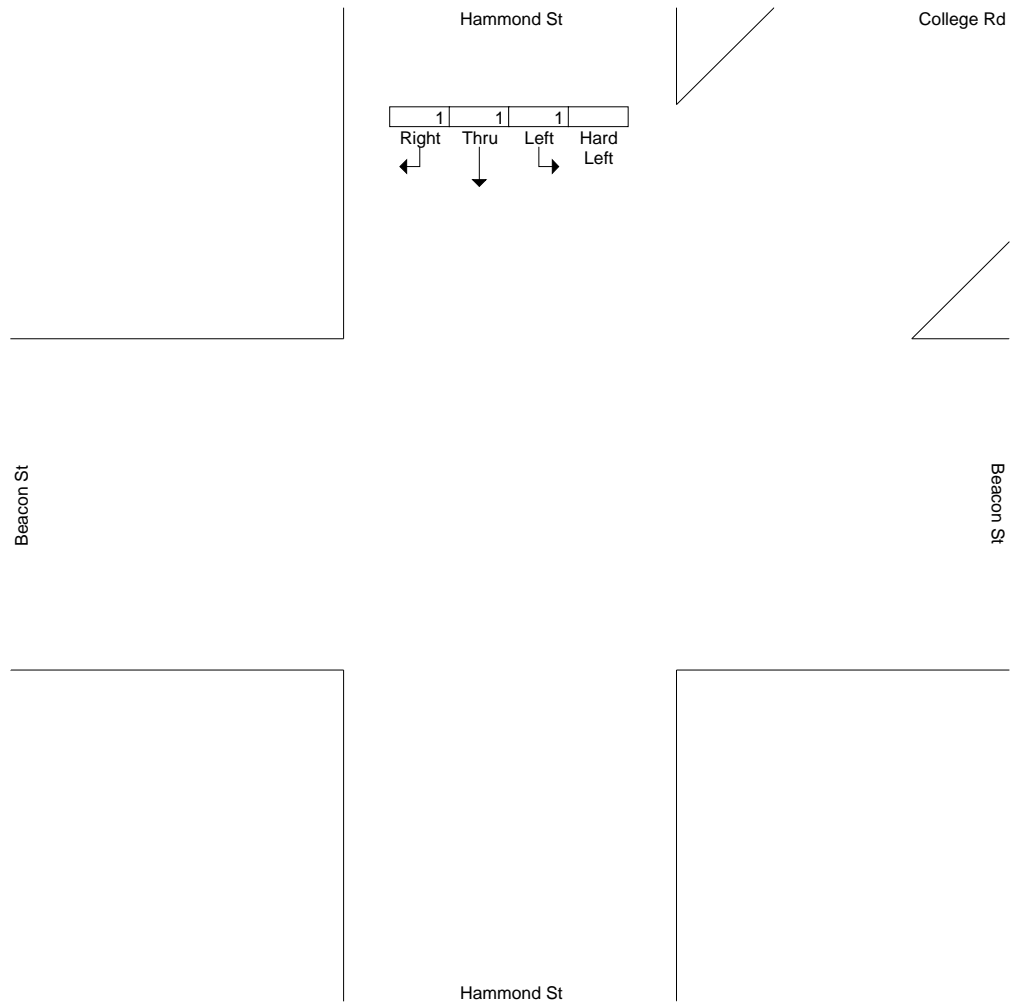

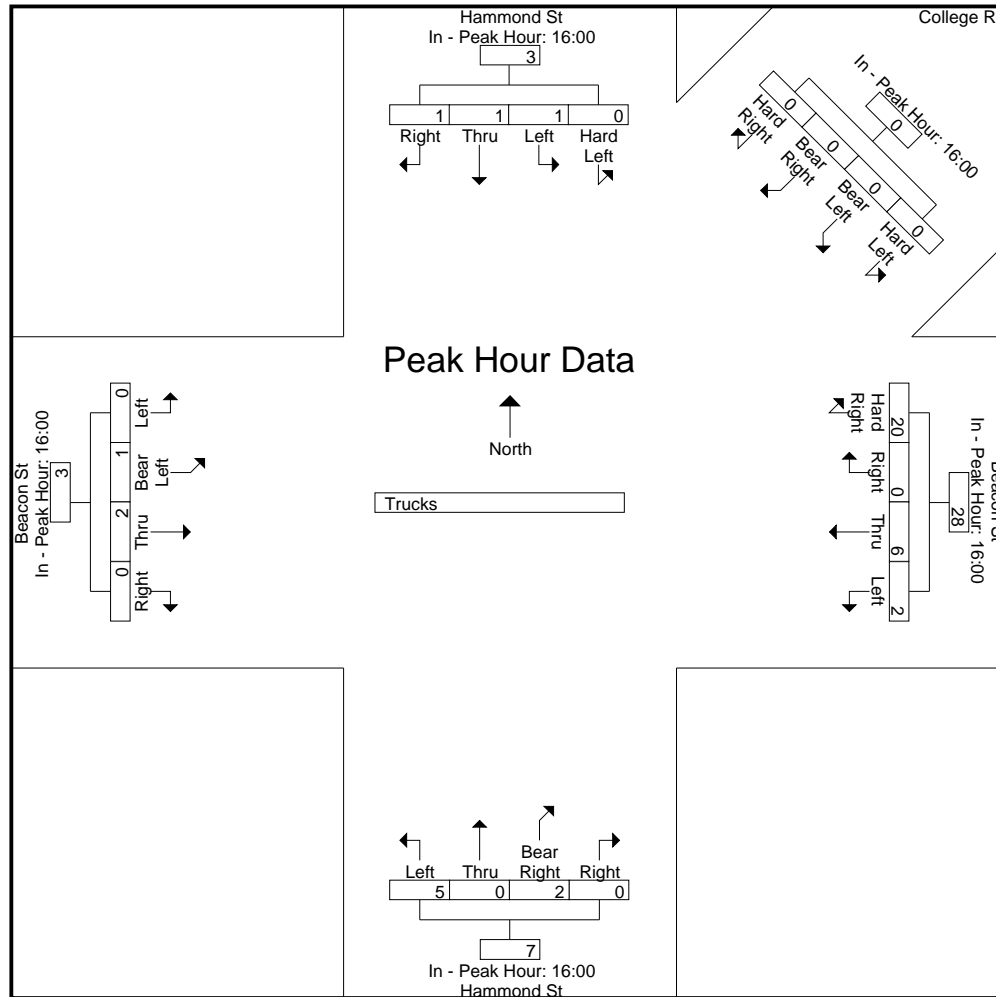

N/S Street : Chestnut Hill Avenue
 E/W Street: Beacon Street
 City/State : Boston, MA
 Weather : Clear

Accurate Counts
 978-664-2565

File Name : 39000008
 Site Code : 39000008
 Start Date : 3/11/2008
 Page No : 1

Groups Printed- Cars - Trucks

Start Time	Chestnut Hill Ave From North				Beacon St From East				Chestnut Hill Ave From South				Beacon St From West				Exclu. Total	Inclu. Total	Int. Total
	Left	Thru	Right	Peds	Left	Thru	Right	Peds	Left	Thru	Right	Peds	Left	Thru	Right	Peds			
07:00	30	82	17	9	33	49	27	39	3	126	22	8	10	60	10	2	58	469	527
07:15	34	137	26	12	41	72	26	64	9	153	12	2	14	81	15	2	80	620	700
07:30	61	165	18	7	39	83	21	100	9	159	9	4	16	89	18	3	114	687	801
07:45	42	141	28	19	42	96	35	83	12	170	25	4	12	134	13	6	112	750	862
Total	167	525	89	47	155	300	109	286	33	608	68	18	52	364	56	13	364	2526	2890
08:00	69	164	24	17	42	86	41	105	15	143	11	6	16	106	18	10	138	735	873
08:15	42	120	27	10	39	125	38	94	30	181	27	3	12	118	11	5	112	770	882
08:30	40	101	27	9	35	101	50	89	16	174	12	2	16	122	6	3	103	700	803
08:45	52	130	18	4	32	99	35	68	27	145	14	3	20	102	18	5	80	692	772
Total	203	515	96	40	148	411	164	356	88	643	64	14	64	448	53	23	433	2897	3330
Grand Total	370	1040	185	87	303	711	273	642	121	1251	132	32	116	812	109	36	797	5423	6220
Apprch %	23.2	65.2	11.6		23.5	55.2	21.2		8	83.2	8.8		11.2	78.3	10.5				
Total %	6.8	19.2	3.4		5.6	13.1	5		2.2	23.1	2.4		2.1	15	2		12.8	87.2	
Cars	361	976	183		293	702	266		120	1192	126		113	803	108		0	0	6040
% Cars	97.6	93.8	98.9	100	96.7	98.7	97.4	100	99.2	95.3	95.5	100	97.4	98.9	99.1	100	0	0	97.1
Trucks	9	64	2		10	9	7		1	59	6		3	9	1		0	0	180
% Trucks	2.4	6.2	1.1	0	3.3	1.3	2.6	0	0.8	4.7	4.5	0	2.6	1.1	0.9	0	0	0	2.9

Start Time	Chestnut Hill Ave From North				Beacon St From East				Chestnut Hill Ave From South				Beacon St From West				Int. Total
	Left	Thru	Right	App. Total	Left	Thru	Right	App. Total	Left	Thru	Right	App. Total	Left	Thru	Right	App. Total	

Peak Hour Analysis From 07:00 to 08:45 - Peak 1 of 1

Peak Hour for Entire Intersection Begins at 07:45:42

07:45 | 42 141 28

Accurate Counts
978-664-2565

File Name : 39000008
Site Code : 39000008
Start Date : 3/11/2008
Page No : 2Out

Chestnut Hill Ave

Out	In	Total
845	787	1632
43	38	81
888	825	1713

Right	Thru	Left
104	495	188
2	31	5
106	526	193

Beacon St

Out	In	Total
736	714	1450
12	16	28
748	730	1478

Right	Thru	Left
159	404	151
5	4	7
164	408	158

Beacon St



Chestnut Hill Ave

Left	Thru	Right
72	631	72
1	37	3
73	668	75

Out	In	Total
693	775	1468
39	41	80
732	816	1548

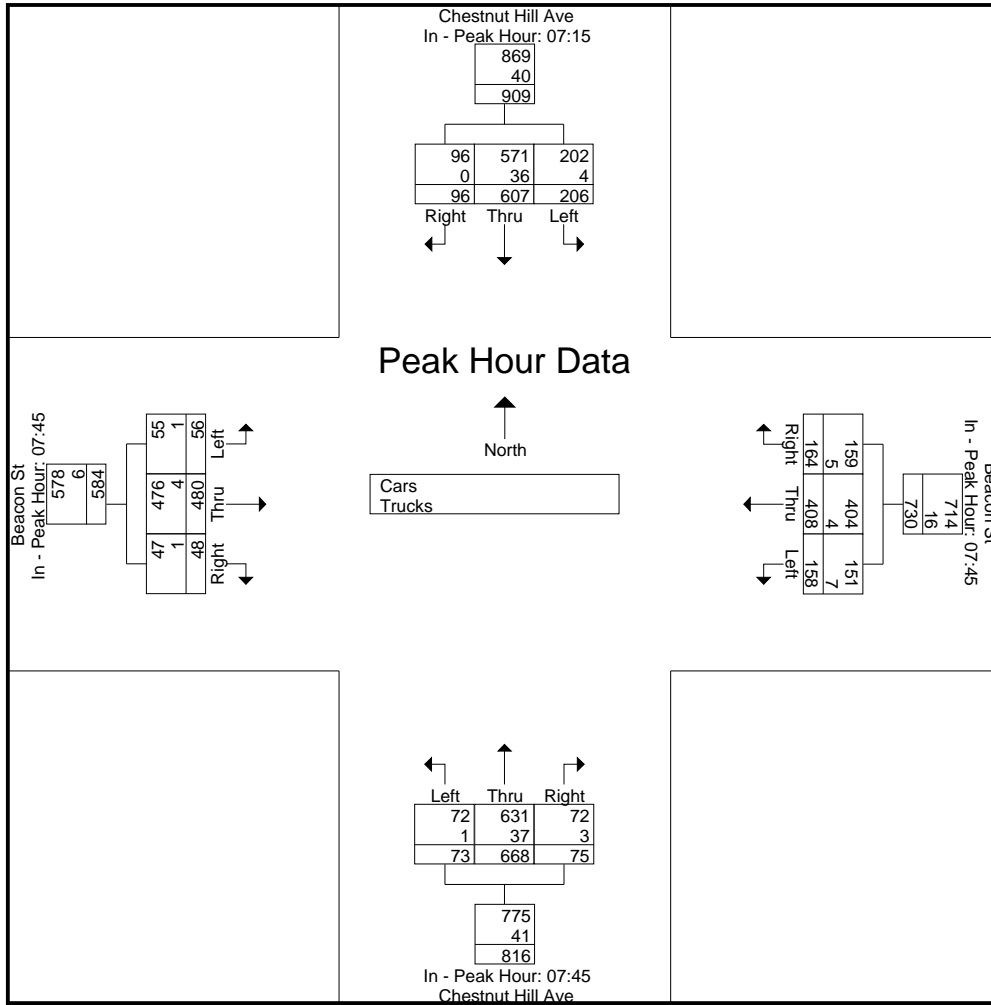

N/S Street : Chestnut Hill Avenue
 E/W Street: Beacon Street
 City/State : Boston, MA
 Weather : Clear

Accurate Counts
 978-664-2565

File Name : 39000008
 Site Code : 39000008
 Start Date : 3/11/2008
 Page No : 1

Groups Printed- Cars

Start Time	Chestnut Hill Ave From North				Beacon St From East				Chestnut Hill Ave From South				Beacon St From West				Exclu. Total	Inclu. Total	Int. Total
	Left	Thru	Right	Peds	Left	Thru	Right	Peds	Left	Thru	Right	Peds	Left	Thru	Right	Peds			
07:00	29	77	17	9	32	48	27	39	3	119	22	8	10	59	10	2	58	453	511

Accurate Counts
978-664-2565

File Name : 39000008
Site Code : 39000008
Start Date : 3/11/2008
Page No : 2

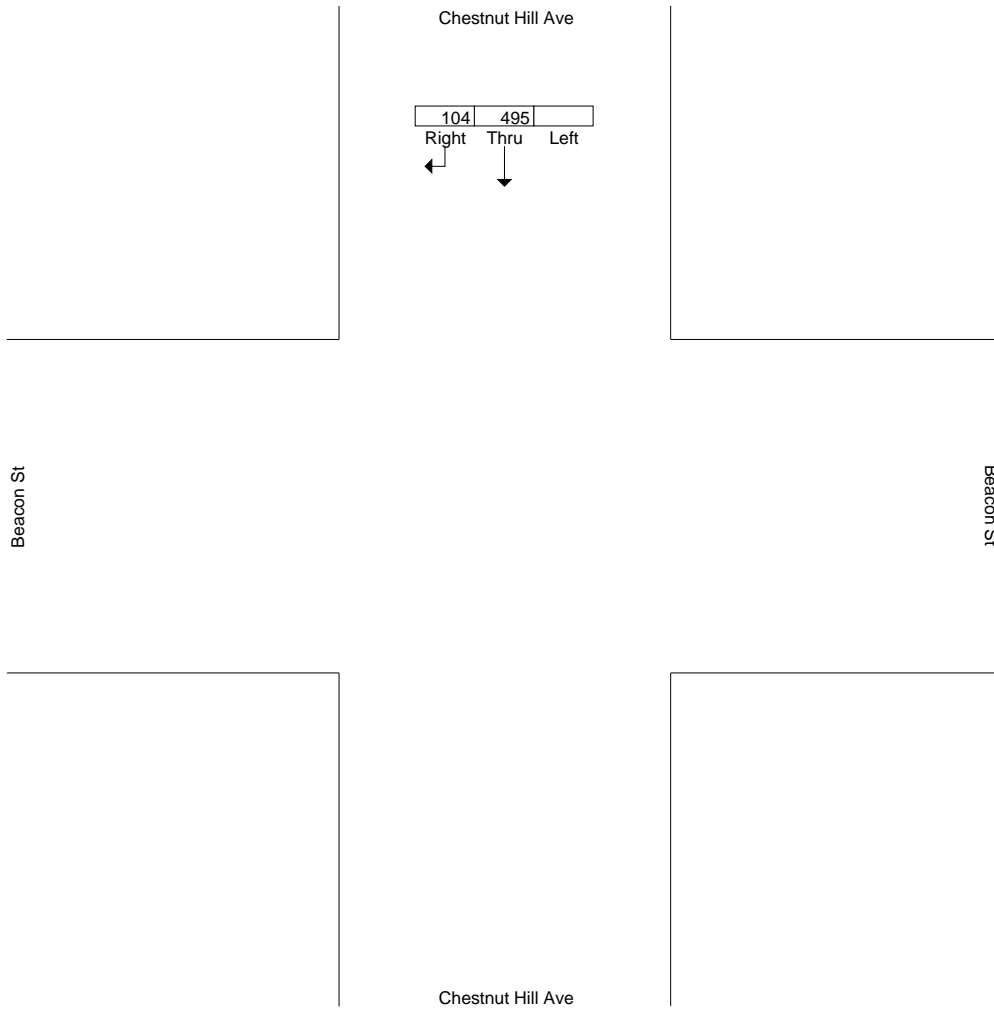

Accurate Counts
978-664-2565

File Name : 39000008
Site Code : 39000008
Start Date : 3/11/2008
Page No : 3

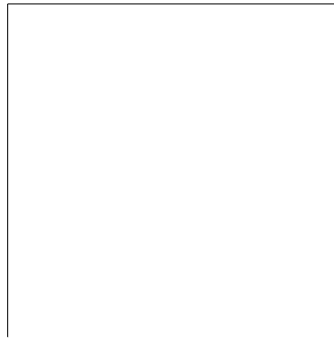
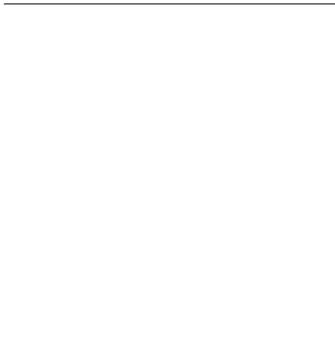
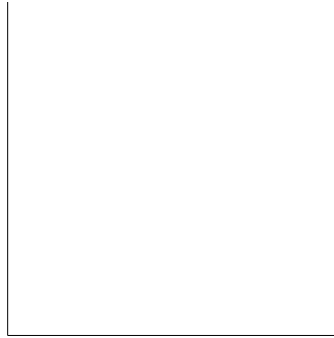

N/S Street : Chestnut Hill Avenue
 E/W Street: Beacon Street
 City/State : Boston, MA
 Weather : Clear

Accurate Counts
 978-664-2565

File Name : 39000008
 Site Code : 39000008
 Start Date : 3/11/2008
 Page No : 1

Groups Printed- Trucks

Start Time	Chestnut Hill Ave From North				Beacon St From East				Chestnut Hill Ave From South				Beacon St From West				Exclu. Total	Inclu. Total	Int. Total	
	Left	Thru	Right	Peds	Left	Thru	Right	Peds	Left	Thru	Right	Peds	Left	Thru	Right	Peds				
07:00	1	5	0	0	1	1	0	0	0	7	0	0	0	1	0	0	0	0	16	16
07:15	1	7	0	0	1	1	2	0	0	6	2	0	0	1	0	0	0	0	21	21
07:30	2	13	0	0	1	1	0	0	0	5	1	0	2	1	0	0	0	0	26	26
07:45	0	7	0	0	3	1	1	0	0	7	1	0	1	2	0	0	0	0	23	23
Total	4	32	0	0	6	4	3	0	0	25	4	0	3	5	0	0	0	0	86	86
08:00	1	9	0	0	1	0	2	0	0	9	1	0	0	0	0	0	0	0	23	23
08:15	2	7	2	0	0	2	1	0	1	12	1	0	0	1	1	0	0	0	30	30
08:30	2	8	0	0	3	1	1	0	0	9	0	0	0	1	0	0	0	0	25	25
08:45	0	8	0	0	0	2	0	0	0	4	0	0	0	2	0	0	0	0	16	16
Total	5	32	2	0	4	5	4	0	1	34	2	0	0	4	1	0	0	0	94	94
Grand Total	9	64	2	0	10	9	7	0	1	59	6	0	3	9	1	0	0	0	180	180
Apprch %	12	85.3	2.7											7.7						

Accurate Counts
978-664-2565

File Name : 39000008
Site Code : 39000008
Start Date : 3/11/2008
Page No : 2

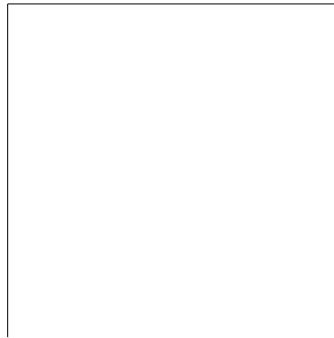
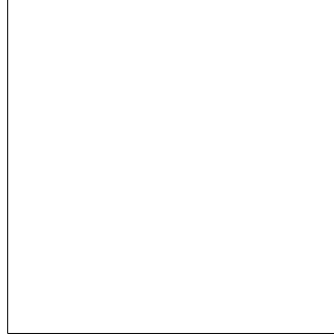

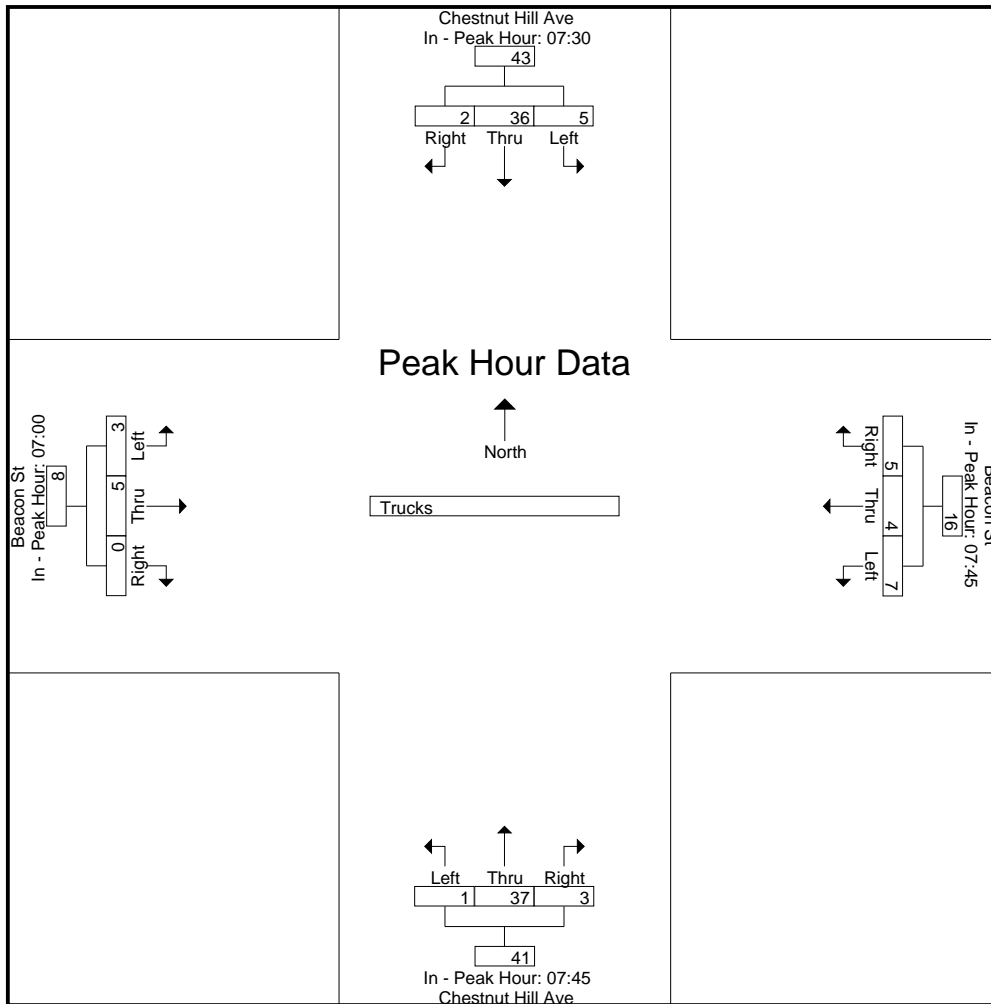

Accurate Counts
978-664-2565

File Name : 39000008
Site Code : 39000008
Start Date : 3/11/2008
Page No : 2

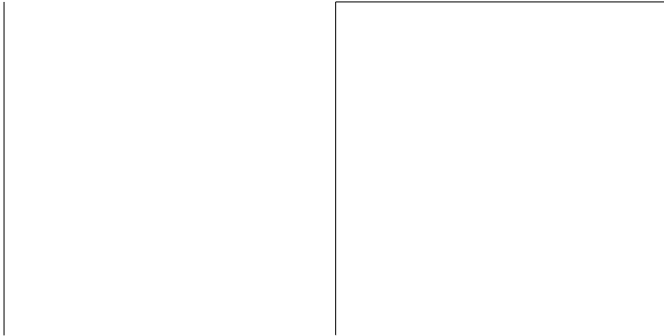
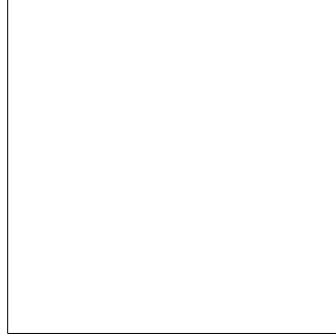

Accurate Counts
978-664-2565

File Name : 39000008
Site Code : 39000008
Start Date : 3/11/2008
Page No : 3

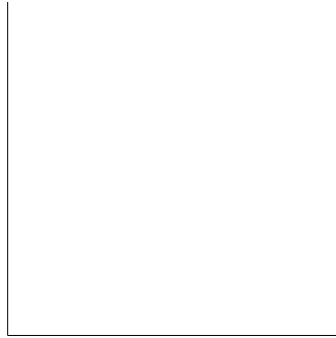

N/S Street : Chestnut Hill Avenue
E/W Street: Beacon Street

Accurate Counts
978-664-2565

File Name : 39000008
Site Code : 39000008
Start Date : 3/11/2008
Page No : 1

Accurate Counts
978-664-2565

File Name : 39000008
Site Code : 39000008
Start Date : 3/11/2008
Page No : 2

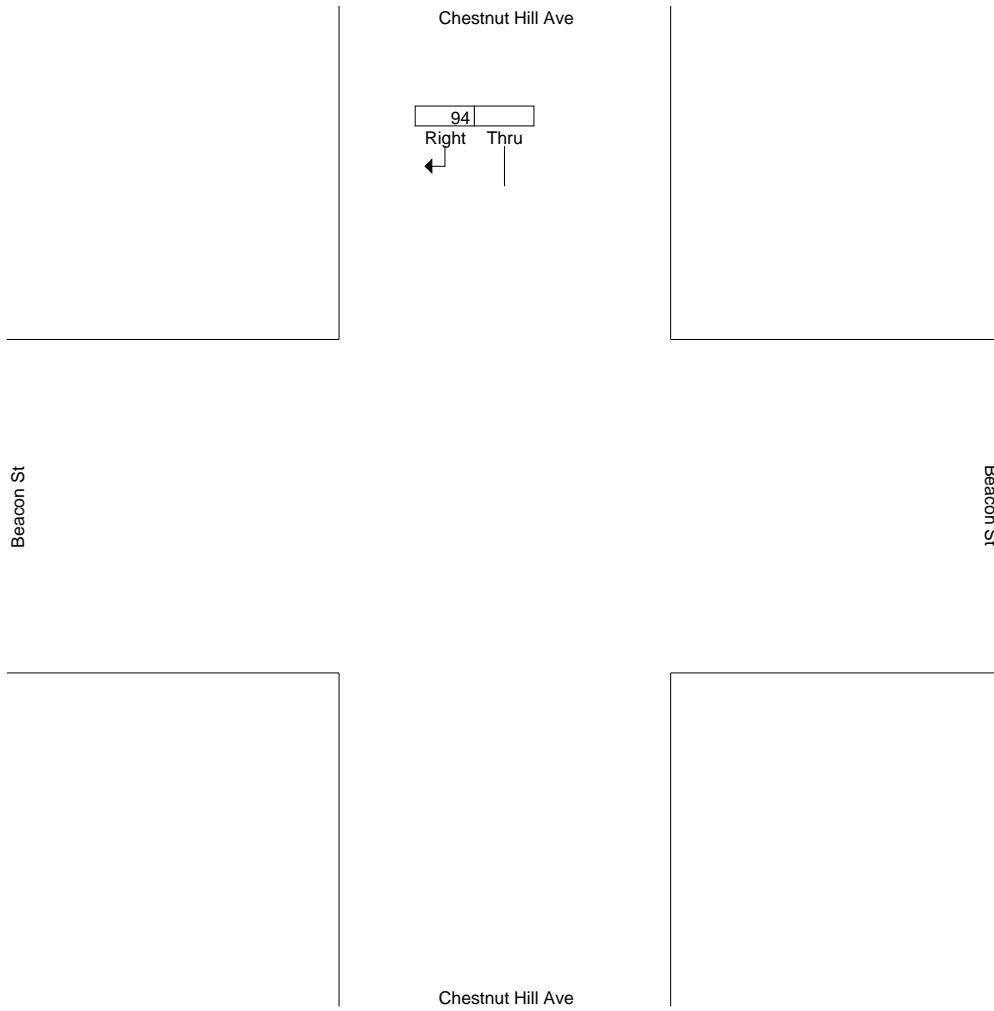

Accurate Counts
978-664-2565

File Name : 39000008
Site Code : 39000008
Start Date : 3/11/2008
Page No : 3

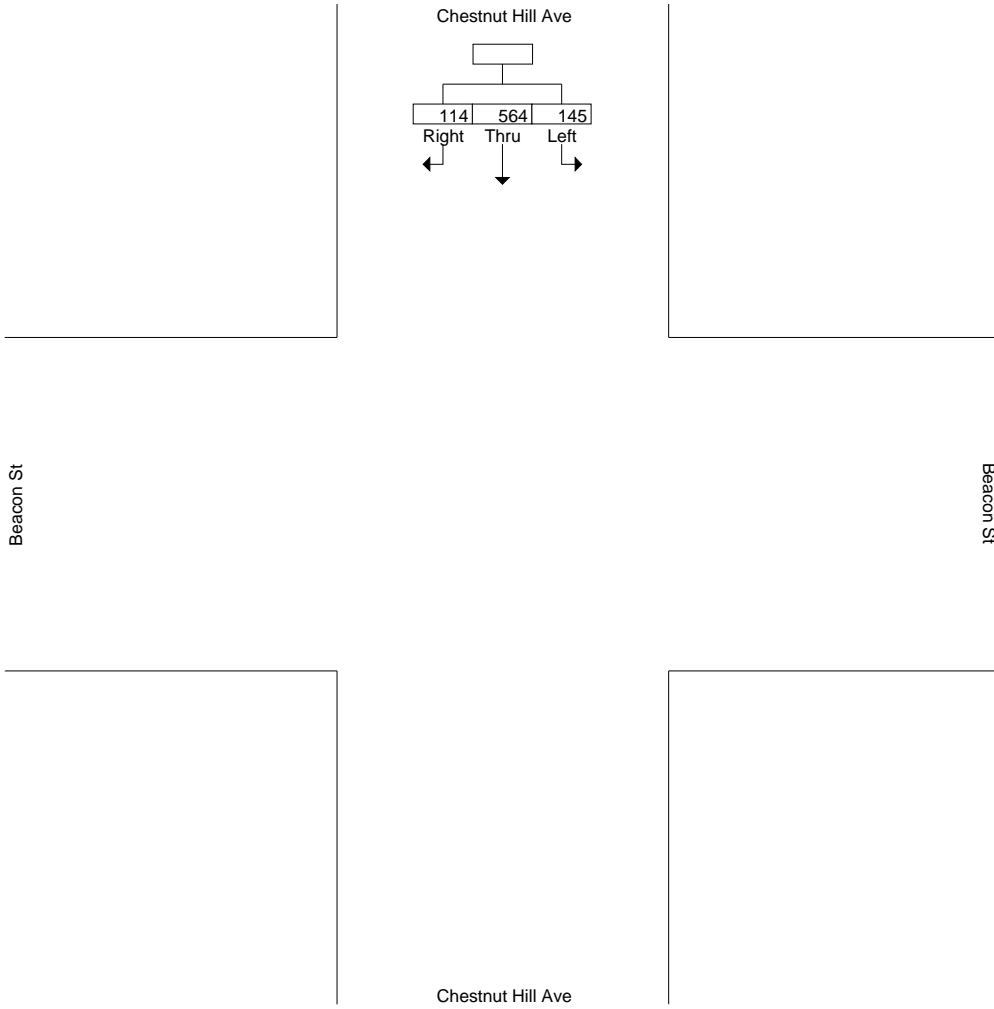

N/S Street : Chestnut Hill Avenue
E/W Street: Beacon Street
City/State : Boston, MA
Weather : Clear

Accurate Counts
978-664-2565

File Name : 39000008
Site Code : 39000008
Start Date : 3/11/2008
Page No : 1

Groups Printed- Trucks

Accurate Counts
978-664-2565

File Name : 39000008
Site Code : 39000008
Start Date : 3/11/2008
Page No : 2

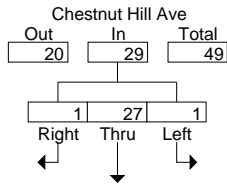

Beacon St

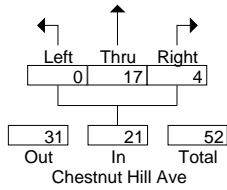
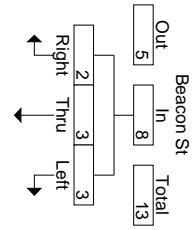

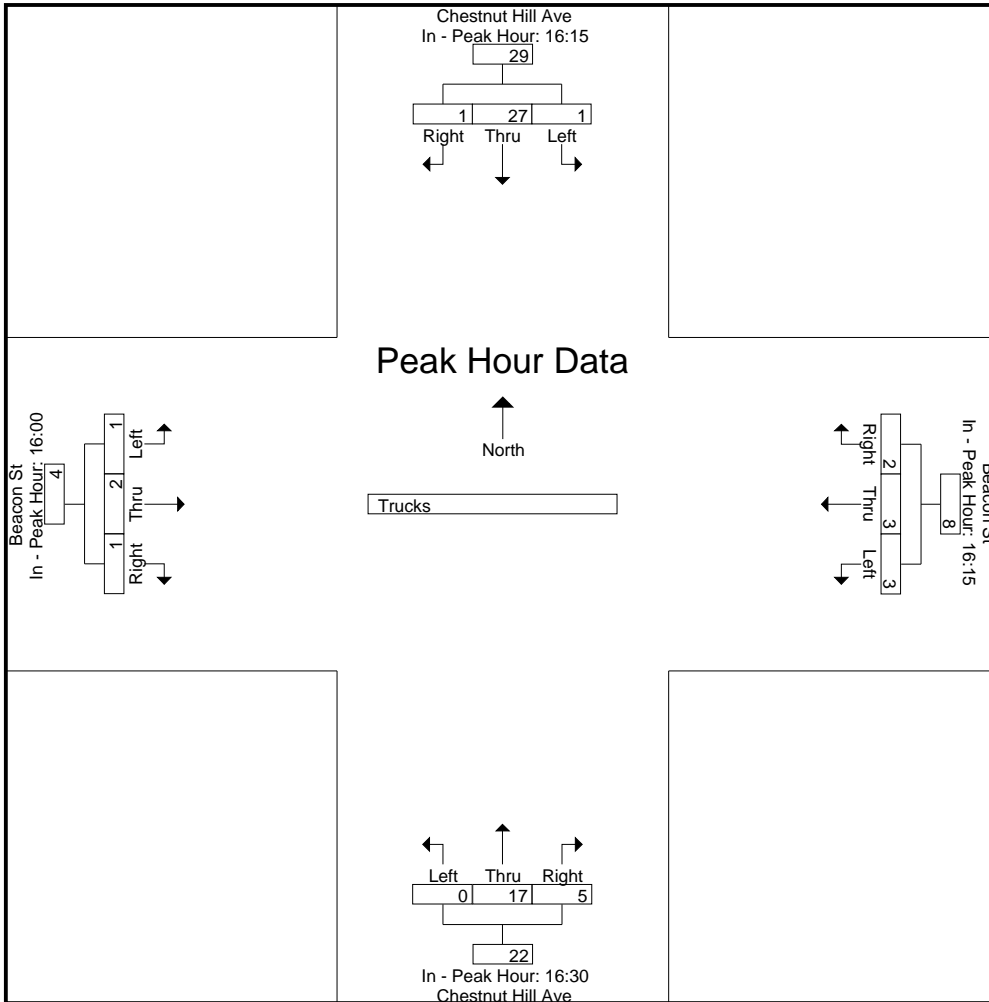

Accurate Counts
978-664-2565

File Name : 39000009
Site Code : 39000009
Start Date : 3/11/2008
Page No : 2

Chestnut Hill Dr

13	
2	
15	

Right Thru
←

Beacon St

Beacon St

Reservoir Ave

Accurate Counts
978-664-2565

File Name : 39000009
Site Code

Accurate Counts
978-664-2565

File Name : 39000009
Site Code : 39000009
Start Date : 3/11/2008
Page No : 3

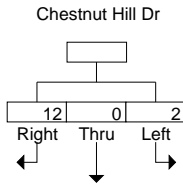

Beacon St

Beacon St

Reservoir Ave

Accurate Counts
978-664-2565

File Name : 39000009

Accurate Counts
978-664-2565

File Name : 39000009
Site Code : 39000009
Start Date : 3/11/2008
Page No : 2

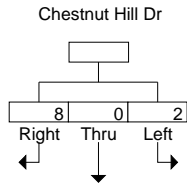

Beacon St

Beacon St

Reservoir Ave

Accurate Counts
978-664-2565

File Name : 39000009
Site Code : 39000009
Start Date : 3/11/2008
Page No : 2

Chestnut Hill Dr

Out	In	Total
51 0	146 0	197 0

	Right	Thru	Left
	96 0	1 0	49 0
	96	1	49

← ↓ →

Beacon St

Beacon St

Reservoir Ave

N/S Street : Reservoir Avenue
E/W Street: Beacon Street
City/State : Newton, MA
Weather : Clear

Accurate Counts
978-664-2565

File Name : 39000009
Site Code : 39000009
Start Date : 3/11/2008
Page No : 1

Groups Printed- Cars

	Chestnut Hill Dr From North		Beacon St From East	Reservoir Ave From South	Beacon St From West
Start Time	Left	Thru			

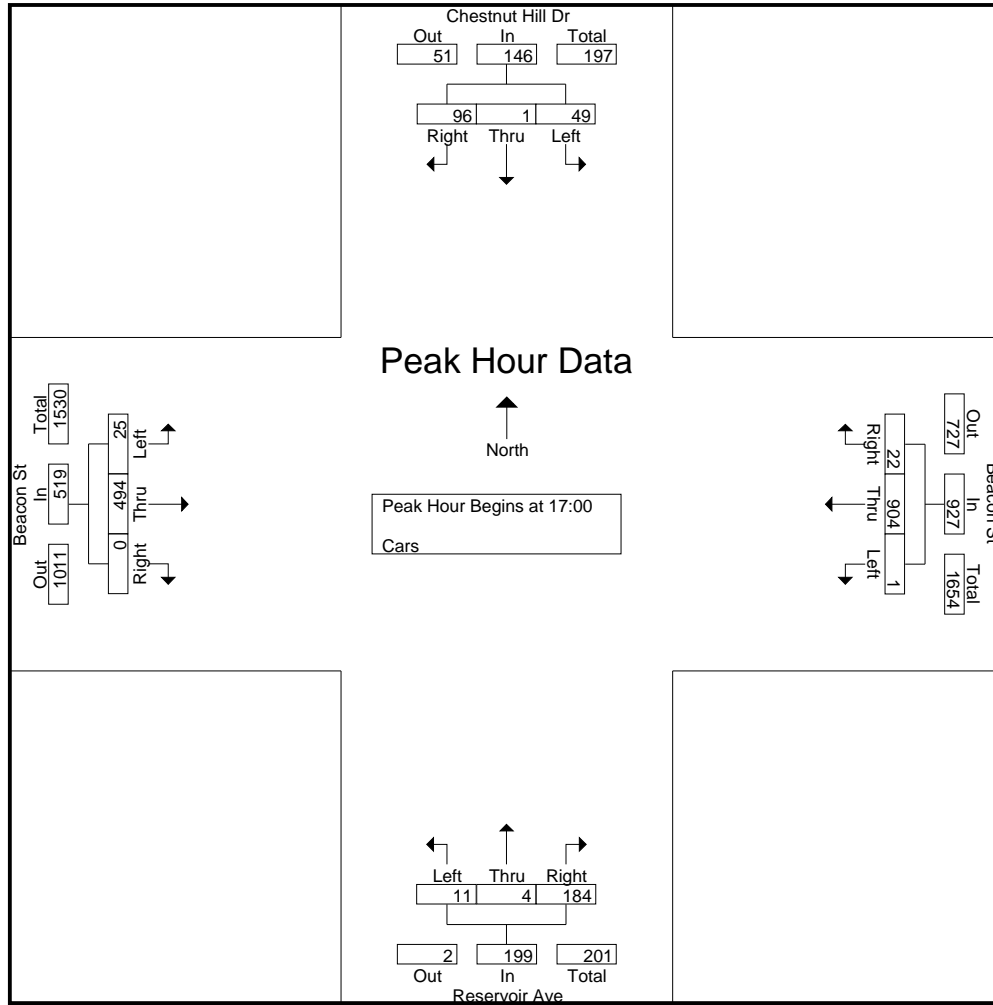

Peak Hour Analysis From 16:00 to 17:45 - Peak 1 of 1

Peak Hour for Each Approach Begins at:

	16:30				17:00				17:00							
+0 mins.	5	0	29	34	0	213	4	217	0	2	41	43	2	109	0	111
+15 mins.	9	0	20	29	0	246	7	253	7	1	43	51	8	136	0	144
+30 mins.	19	1	25	45	0	214	4	218	0	1	51	52	7	141	0	148
+45 mins.	15	0	28	43	1	231	7	239	4	0	49	53	8	108	0	116
Total Volume	48	1	102	151	1	904	22	927	11	4	184	199	25	494	0	519
% App. Total	31.8	0.7	67.5		0.1	97.5	2.4		5.5	2	92.5		4.8	95.2	0	
PHF	.632	.250	.879	.839	.250	.919	.786	.916	.393	.500	.902	.939	.781	.876	.000	.877

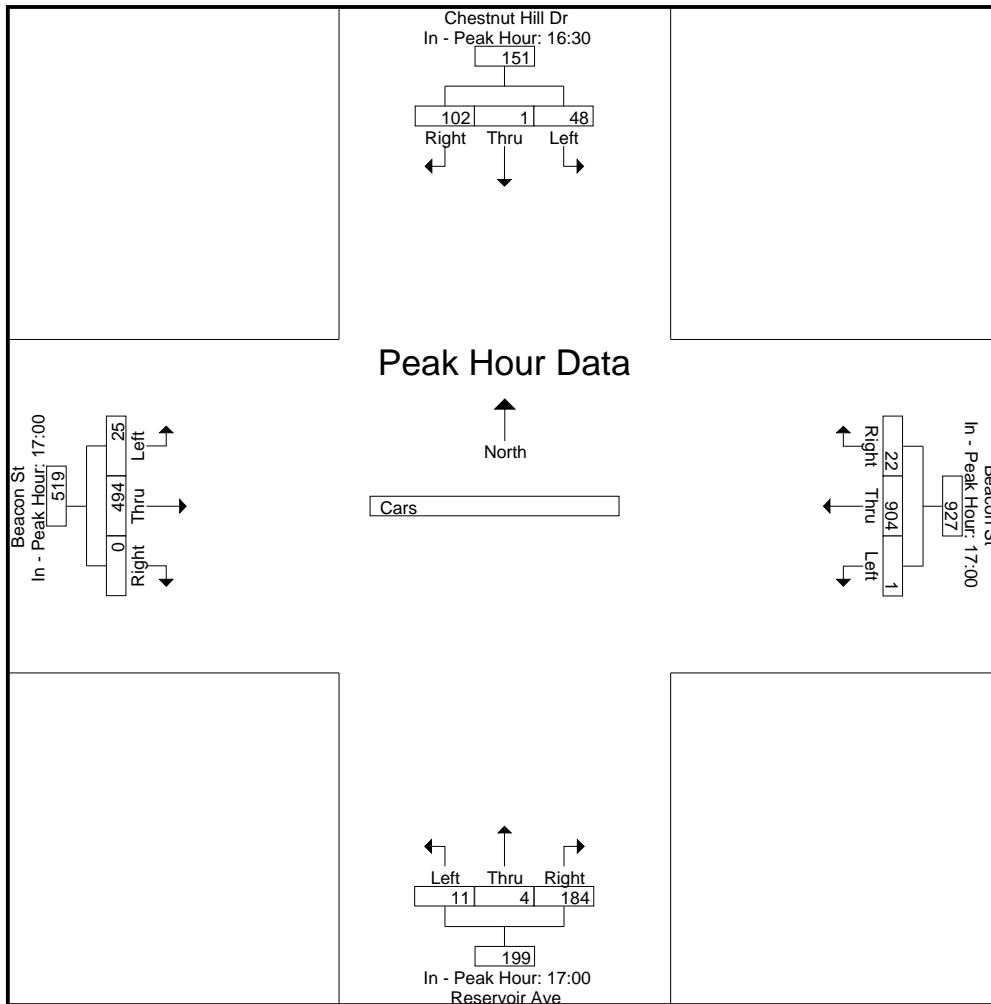

Accurate Counts
978-664-2565

File Name : 39000009
Site Code : 39000009

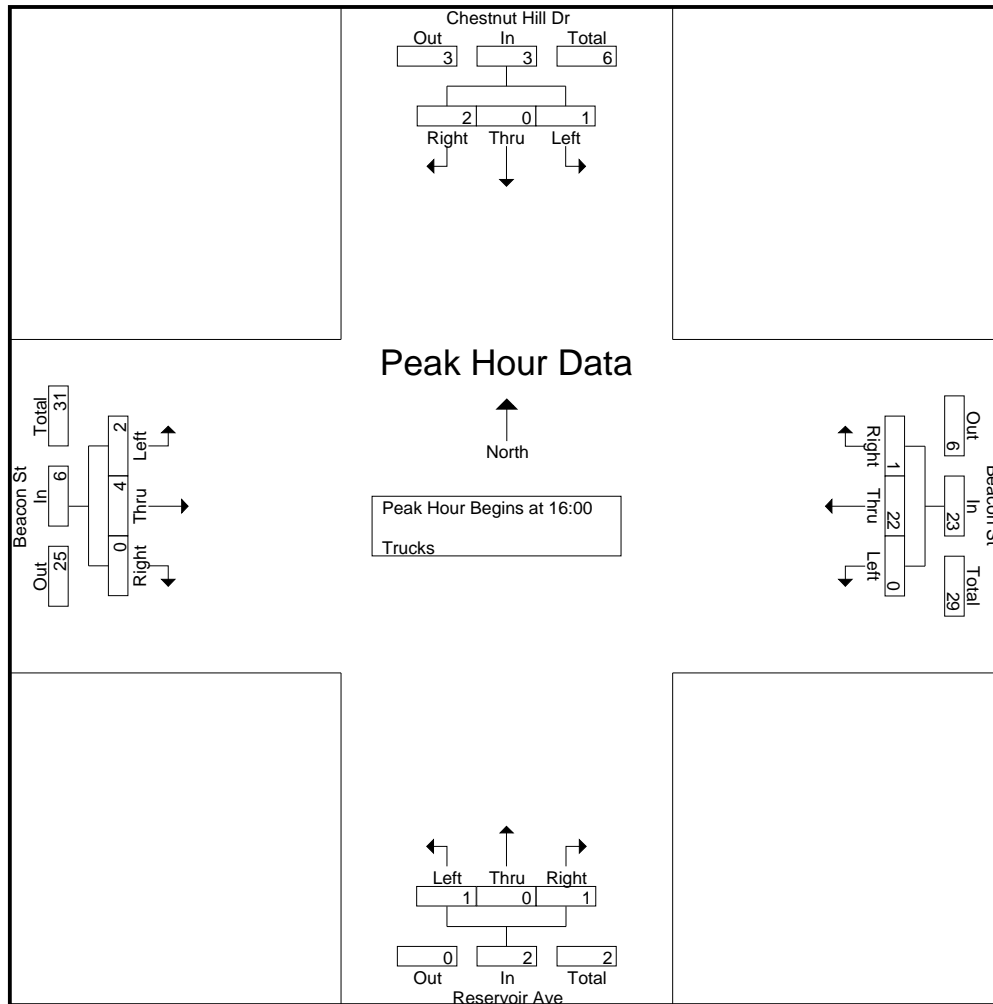

Peak Hour Analysis From 16:00 to 17:45 - Peak 1 of 1

Peak Hour for Each Approach Begins at:

+0 mins.	16:00	16:00	16:00	16:00	16:00
	0	0	0	0	0
	0	5	1	6	

Accurate Counts
978-664-2565

File Name : 39000009
Site Code : 39000009
Start Date : 3/11/2008
Page No : 3

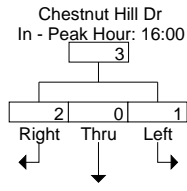

Beacon St

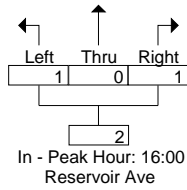
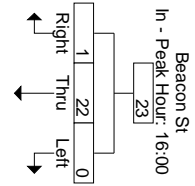

N/S Street : St Thomas Moore Road
 E/W Street: Beacon Street
 City/State : Brighton, MA
 Weather : Clear

Accurate Counts
 978-664-2565

File Name : 39000015
 Site Code : 39000015
 Start Date : 3/11/2008
 Page No : 1

Groups Printed- Cars - Trucks

Start Time	St Thomas Moore Rd From North				Beacon St From East				Gate House Rd From South				Beacon St From West				Exclu. Total	Inclu. Total	Int. Total
	Left	Thru	Right	Peds	Left	Thru	Right	Peds	Left	Thru	Right	Peds	Left	Thru	Right	Peds			
07:00	2	1	32	2	1	66	8	0	0	0	0	3	49	81	1	1	6	241	247
07:15	6	0	36	0	0	89	9	0	2	3	1	0	72	120	1	0	0	339	339
07:30	5	2	56	2	0	113	14	1	1	1	0	0	66	141	1	0	3	400	403
07:45	4	0	52	3	0	131	20	0	1	1	2	2	100	189	3	0	5	503	508
Total	17	3	176	7	1	399	51	1	4	5	3	5	287	531	6	1	14	1483	1497
08:00	8	0	49	2	0	136	7	0	0	0	0	3	89	154	3	0	5	446	451
08:15	5	0	53	2	2	175	27	0	3	3	1	0	90	158	0	0	2	517	519
08:30	6	2	58	1	1	153	18	2	1	1	1	0	92	167	2	0	3	502	505
08:45	8	1	49	0	1	161	28	0	1	0	0	0	92	175	3	2	2	519	521
Total	27	3	209	5	4	625	80	2	5	4	2	3	363	654	8	2	12	1984	1996
Grand Total	44	6	385	12	5	1024	131	3	9	9	5	8	650	1185	14	3	26	3467	3493
Apprch %	10.1	1.4	88.5		0.4	88.3	11.3		39.1	39.1	21.7		35.2	64.1	0.8				
Total %	1.3	0.2	11.1		0.1	29.5	3.8		0.3	0.3	0.1		18.7	34.2	0.4		0.7	99.3	
Cars	42	6	343		3	1003	126		9	9	5		619	1160	9		0	0	3360
% Cars	95.5	100	89.1	100	60	97.9	96.2	100	100	100	100	100	95.2	97.9	64.3	100	0	0	96.2
Trucks	2	0	42		2	21	5		0	0	0		31	25	5		0	0	133
% Trucks	4.5	0	10.9	0	40	2.1	3.8	0	0	0	0	0	4.8	2.1	35.7	0	0	0	3.8

0Thru369.34 .9 (Thru360 70.56 616.8

Start Time	St Thomas Moore Rd From North				Beacon St From East				Gate House Rd From South				Beacon St From West				Exclu. Total	Inclu. Total	Int. Total
	Left	Thru	Right	App. Total	Left	Thru	Right	App. Total	Left	Thru	Right	App. Total	Left	Thru	Right	App. Total			
Peak Hour	584	589.2	406	523.44	489.2	1489.66	8	1489.66	306.72	489.1	278.88	415.61	53.8	415.61	589.2				

Accurate Counts
978-664-2565

File Name : 39000015
Site Code : 39000015
Start Date : 3/11/2008
Page No : 2

St Thomas Moore Rd

Out	In	Total
427	215	642
20	24	44
447	239	686

Right	Thru	Left
187	3	25
22	0	2
209	3	27

Beacon St

Beacon St

Out	In	Total
668	693	1361
15	16	31
683	709	1392

Right	Thru	Left
77	613	3
3	12	1
80	625	4

Left	Thru
5	
0	
5	

Gate House Rd

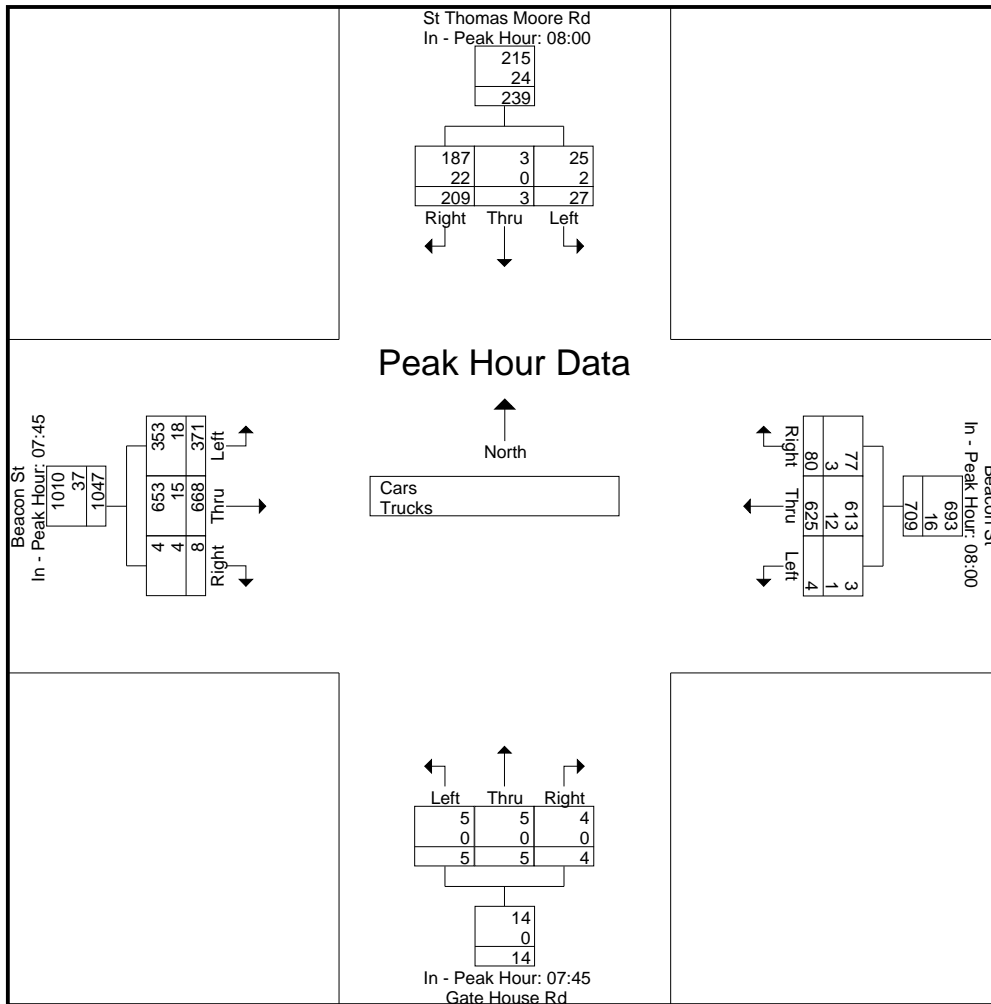

Accurate Counts
978-664-2565

File Name : 39000015

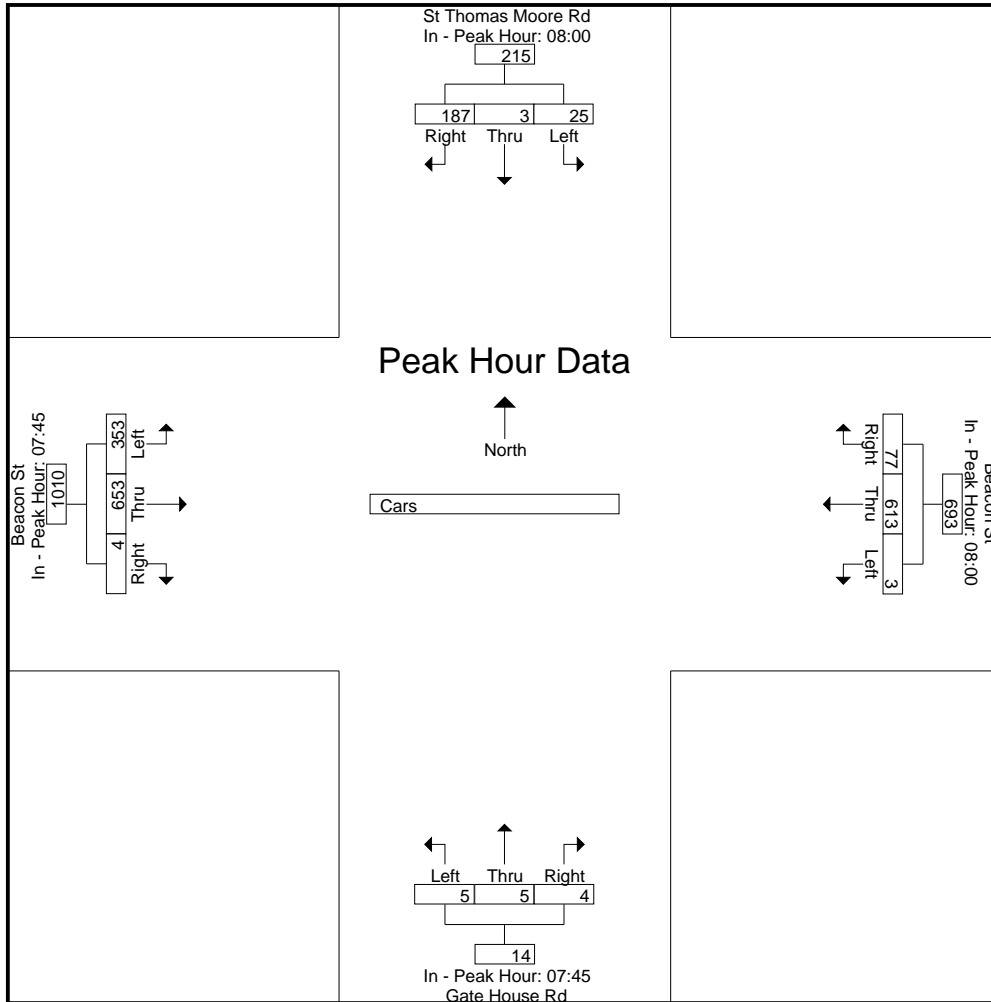

Accurate Counts
978-664-2565

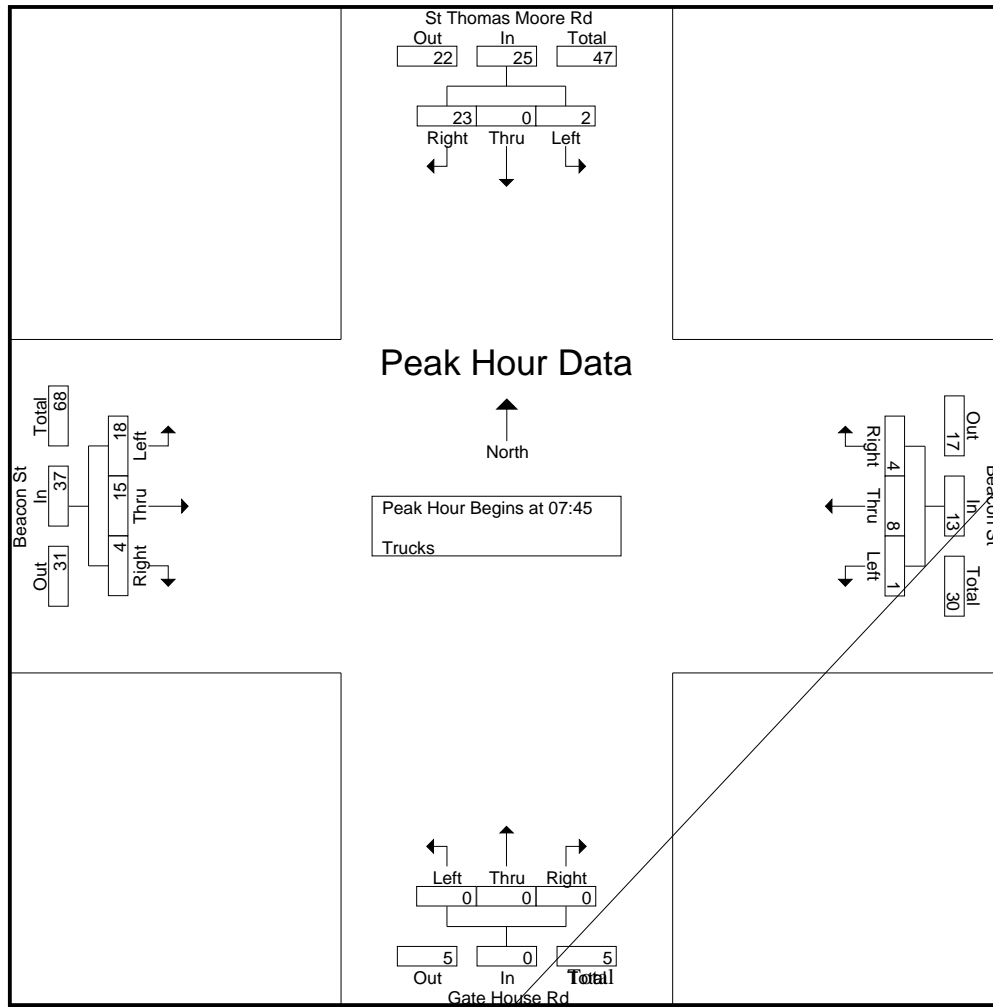

Peak Hour Analysis From 07:00 to 08:45 - Peak 1 of 1
Peak Hour for Each Approach Begins at:



Accurate Counts
978-664-2565

File Name : 39000015
Site Code : 39000015
Start Date : 3/11/2008
Page No : 3

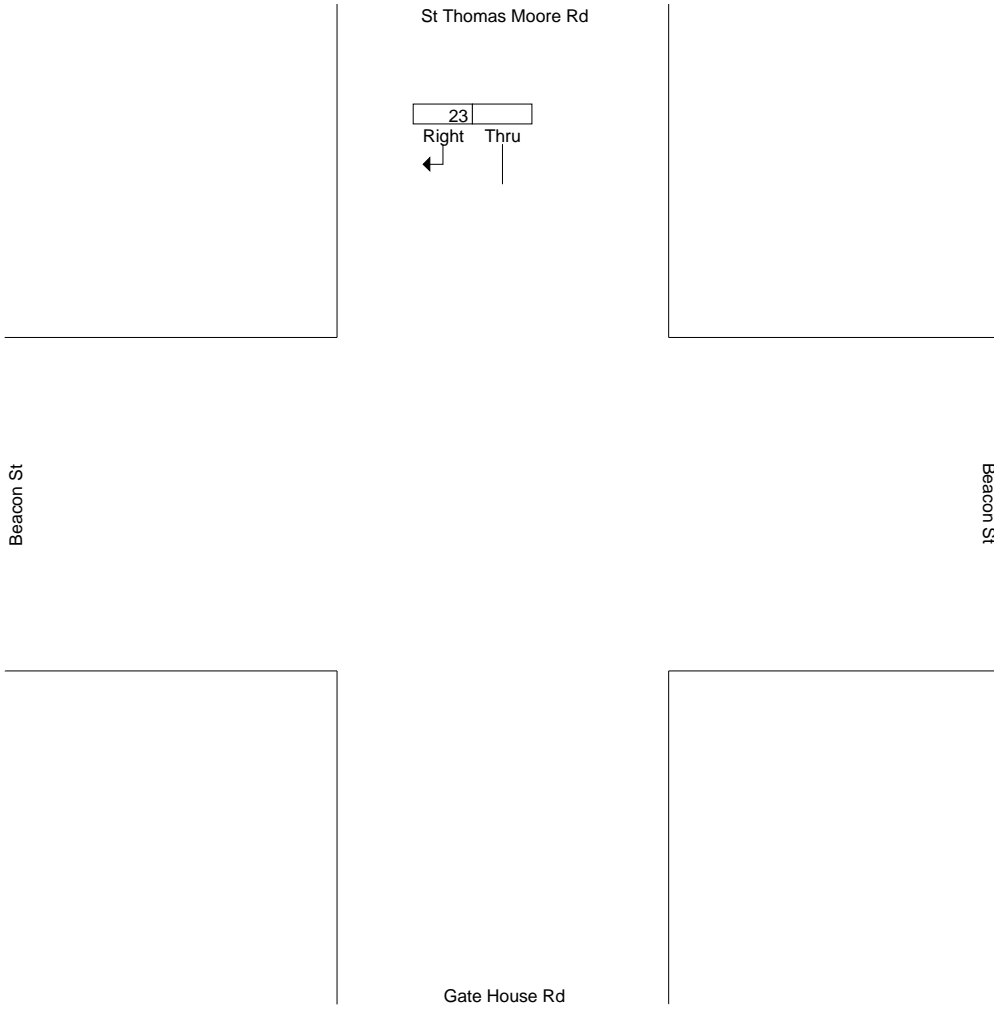

N/S Street : St Thomas Moore Road
E/W Street: Beacon Street

Accurate Counts
978-664-2565

File Name : 39000015
Site Code : 39000015
Start Date : 3/11/2008
Page No : 1

N/S Street : St Thomas Moore Road
 E/W Street: Beacon Street
 City/State : Brighton, MA
 Weather : Clear

Accurate Counts
 978-664-2565

File Name : 39000015
 Site Code : 39000015
 Start Date : 3/11/2008
 Page No : 1

Groups Printed- Cars

Start Time	St Thomas Moore Rd From North				Beacon St From East				Gate House Rd From South				Beacon St From West				Exclu. Total	Inclu. Total	Int. Total
	Left	Thru	Right	Peds	Left	Thru	Right	Peds	Left	Thru	Right	Peds	Left	Thru	Right	Peds			
16:00	19	0	71	4	0	114	22	1	0	1	0	0	64	77	2	0	5	370	375
16:15	17	4	76	8	3	131	20	0	0	2	3	4	51	79	1	0	12	387	399
16:30	23	1	65	3	0	151	16	1	3	0	2	2	43	95	0	0	6	399	405
16:45	10	3	57	8	3	146	13	3	1	0	1	0	59	90	1	0	11	384	395
Total	69	8	269	23	6	542	71	5	4	3	6	6	217	341	4	0	34	1540	1574
17:00	27	0	74	7	2	141	12	0	1	1	0	1	53	103	1	0	8	415	423
17:15	22	1	73	7	0	180	14	1	1	2	3	0	63	141	1	0	8	501	509
17:30	21	2	55	3	1	159	22	0	3	0	0	0	52	128	1	0	3	444	447
17:45	26	3	71	8	0	162	24	0	2	0	0	1	61	106	1	4	13	456	469
Total	96	6	273	25	3	642	72	1	7	3	3	2	229	478	4	4	32	1816	1848
Grand Total	165	14	542	48	9	1184	143	6	11	6	9	8	446	819	8	4	66	3356	3422
Apprch %	22.9	1.9	75.2		0.7	88.6	10.7		42.3	23.1	34.6		35	64.3	0.6				
Total %	4.9	0.4	16.2		0.3	35.3	4.3		0.3	0.2	0.3		13.3	24.4	0.2		1.9	98.1	

Start Time	St Thomas Moore Rd From North				Beacon St From East				Gate House Rd From South				Beacon St From West				Int. Total
	Left	Thru	Right	App. Total	Left	Thru	Right	App. Total	Left	Thru	Right	App. Total	Left	Thru	Right	App. Total	
Peak Hour Analysis From 16:00 to 17:45 - Peak 1 of 1																	
Peak Hour for Entire Intersection Begins at 17:00																	
17:00	27	0	74	101	2	141	12	155	1	1	0	2	53	103	1	157	415
17:15	22	1	73	96	0	180	14	194	1	2	3	6	63	141	1	205	501
17:30	21	2	55	78	1	159	22	182	3	0	0	3	52	128	1	181	444
17:45	26	3	71	100	0	162	24	186	2	0	0	2	61	106	1	168	456
Total Volume	96	6	273	375	3	642	72	717	7	3	3	13	229	478	4	711	1816
% App. Total	25.6	1.6	72.8		0.4	89.5	10		53.8	23.1	23.1		32.2	67.2	0.6		
PHF	.889	.500	.922	.928	.375	.892	.750	.924	.583	.375	.250	.542	.909	.848	1.000	.867	.906

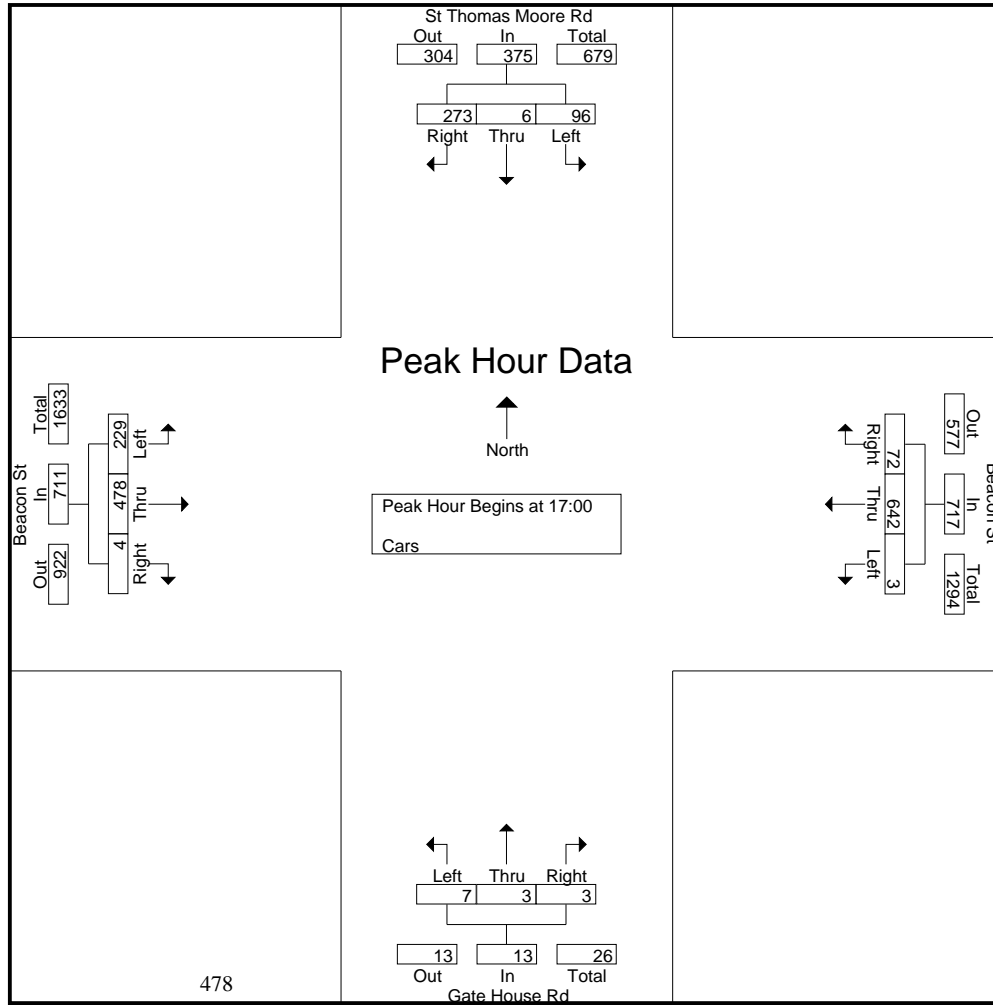

Peak Hour Analysis From 16:00 to 17:45 - Peak 1 of 1

Peak Hour for Each Approach Begins at:

	17:00				17:00				16:30				17:00			
+0 mins.	27	0	74	101	2	141	12	155	3	0	2	5	53	103	1	157
+15 mins.	22	1	73	96	0	180	14	194	1	0	1	2	63	141	1	205
+30 mins.	21	2	55	78	1	159	22	182	1	1	0	2	52	128	1	181
+45 mins.	26	3	71	100	0	162	24	186	1	2	3	6	61	106	1	168
Total Volume	96	6	273	375	3	642	72	717	6	3	6	15	229	478	4	711
% App. Total	25.6	1.6	72.8		0.4	89.5	10		40	20	40					

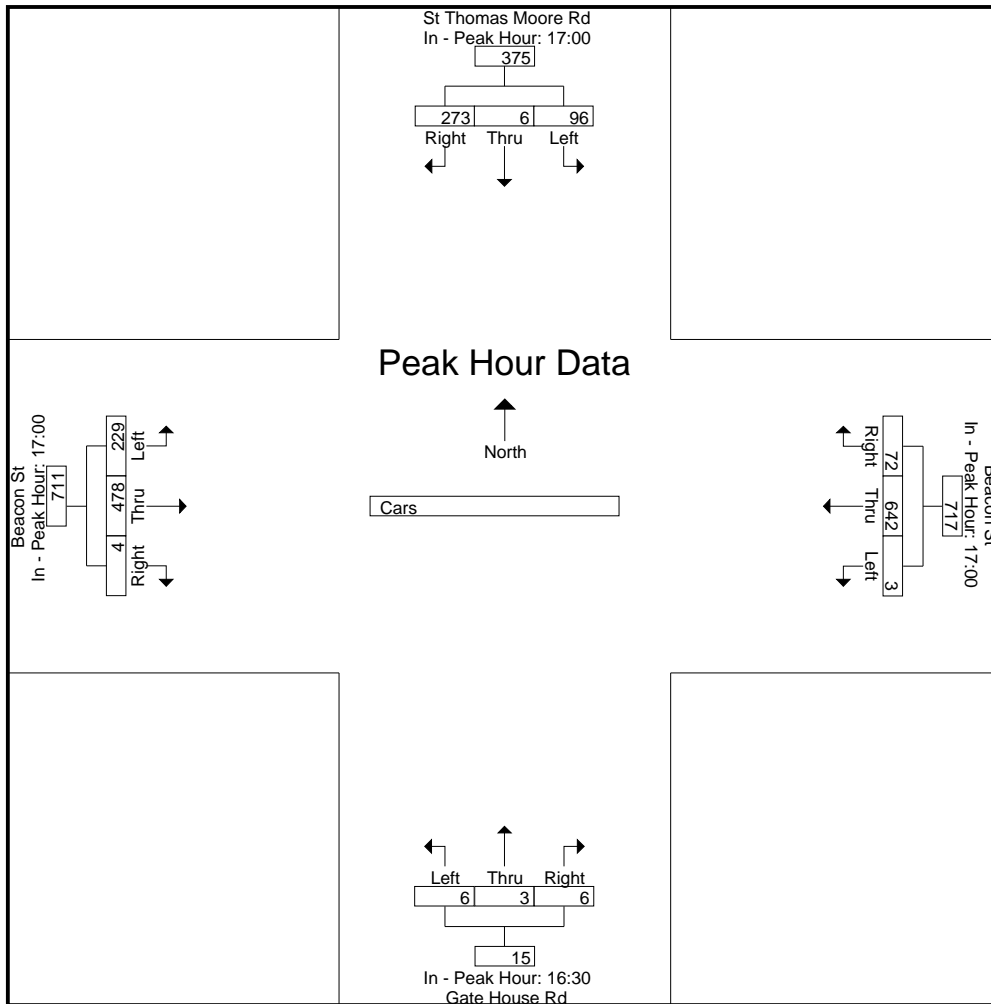

N/S Street : St Thomas Moore Road
E/W Street: Beacon Street

Accurate Counts
978-664-2565

File Name : 39000015
Site Code : 39000015
Start Date : 3/11/2008
Page No : 1

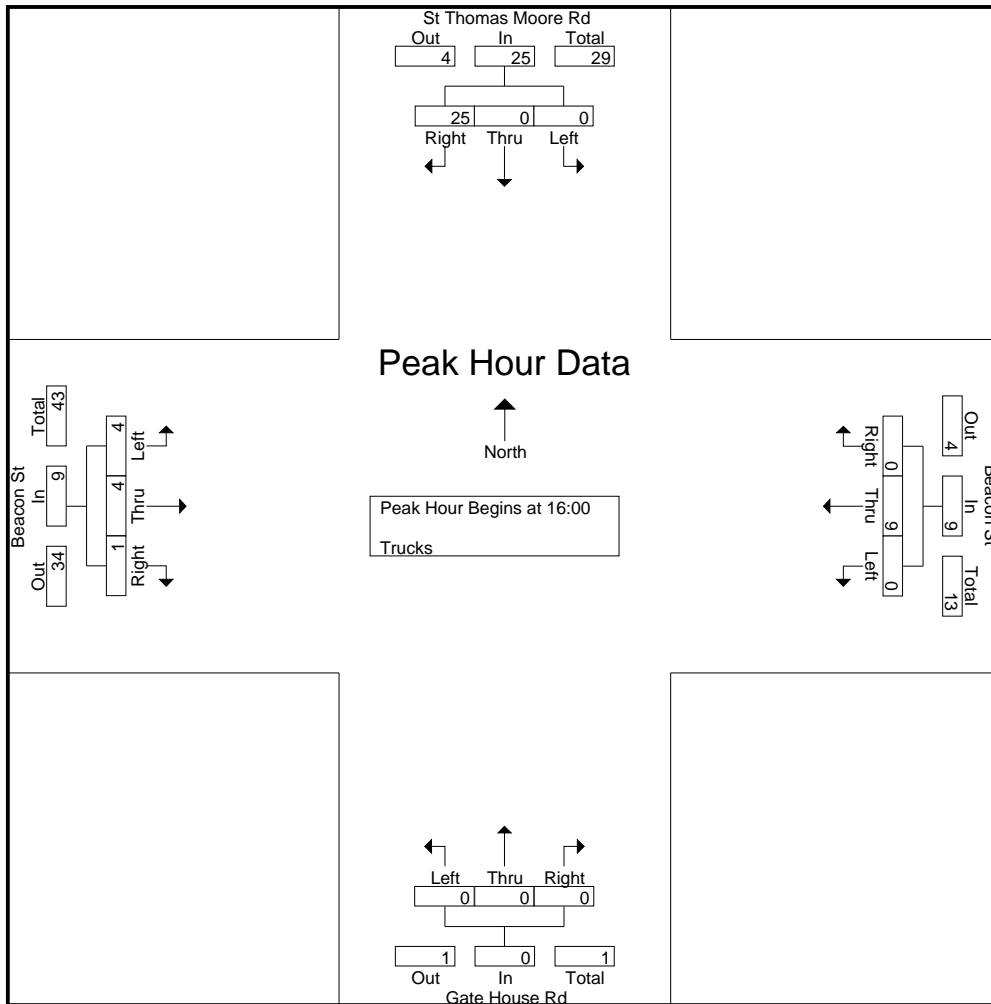

Peak Hour Analysis From 16:00 to 17:45 - Peak 1 of 1

Accurate Counts
978-664-2565

File Name : 39000010
Site Code : 39000010
Start Date : 3/12/2008
Page No : 2

Brock St		
Out	In	Total
327	0	327
3	0	3
330	0	330

Right	Thru	Left
0	0	0
0	0	0
0	0	0

Washington St		
Out	In	Total
501	436	937
25	34	59
526	470	996

Right	Thru	Left
23	413	0
0	34	0
23	447	0

Washington St

Left
1
15

Left	Thru	Right
65	289	99
3	2	3
68	291	102

Lake St		
Out	In	Total
0	453	453
0	8	8
0	461	461

Accurate Counts
978-664-2565

File Name : 39000010
Site Code : 39000010
Start Date : 3/12/2008
Page No : 3

Brock St

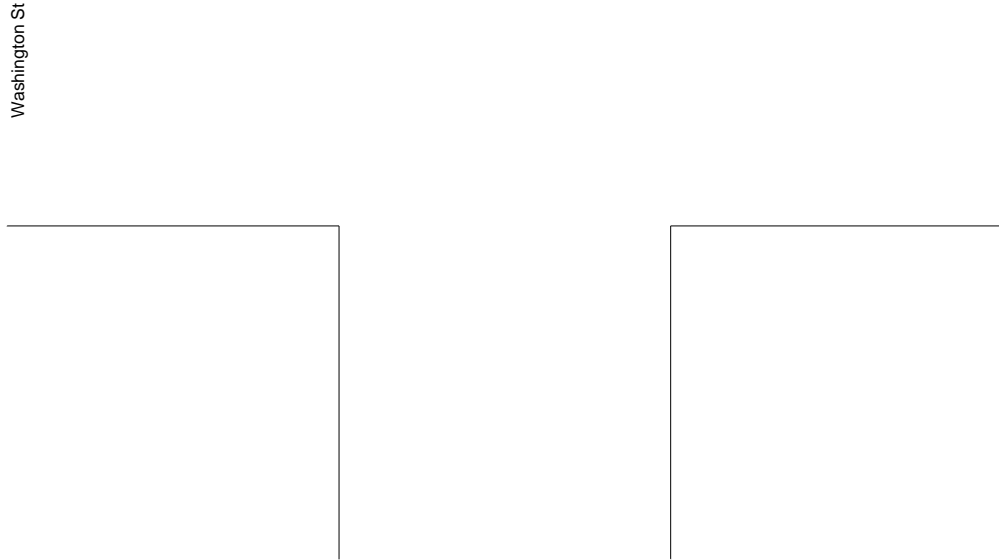
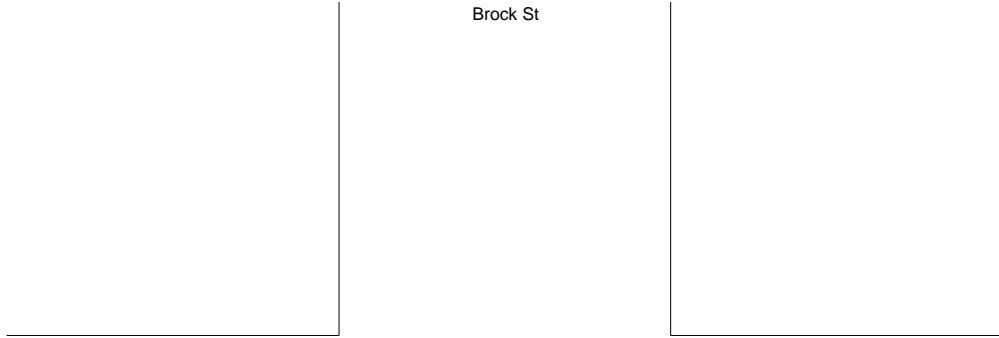

Washington St

N/S Street : Brock St / Lake St
 E/W Street: Washington Street
 City/State : Brighton, MA
 Weather : Rain

Accurate Counts
 978-664-2565

File Name : 39000010
 Site Code : 39000010
 Start Date : 3/12/2008
 Page No : 1

Groups Printed- Cars

Start Time	Brock St From North				Washington St From East				Lake St From South				Washington St From West				Exclu. Total	Inclu. Total	Int. Total
	Left	Thru	Right	Peds	Left	Thru	Right	Peds	Left	Thru	Right	Peds	Left	Thru	Right	Peds			
07:00	0	0	0	4	0	71	3	1	12	34	23	7	7	107	0	6	18	257	275
07:15	0	0	0	4	0	112	4	1	18	56	26	3	2	113	0	8	16	331	347
07:30	0	0	0	8	0	86	8	5	17	77	31	9	5	94	0	12	34	318	352
07:45	0	0	0	6	0	99	5	4	17	81	20	7	4	109	0	17	34	335	369
Total	0	0	0	22	0	368	20	11	64	248	100	26	18	423	0	22			

Accurate Counts
978-664-2565

File Name : 39000010
Site Code : 39000010
Start Date : 3/12/2008
Page No : 2

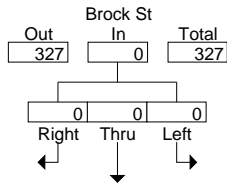

Washington St

Left

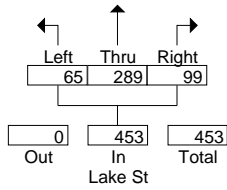
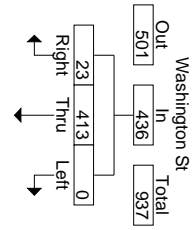

Accurate Counts
978-664-2565

File Name : 39000010
Site Code : 39000010
Start Date : 3/12/2008
Page No : 3

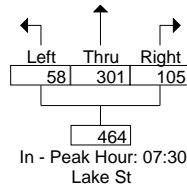
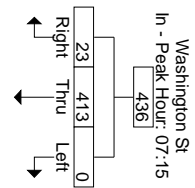
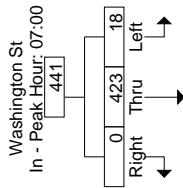
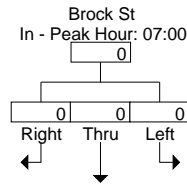

N/S Street : Brock St / Lake St
 E/W Street: Washington Street
 City/State : Brighton, MA
 Weather : Rain

Accurate Counts
 978-664-2565

File Name : 39000010
 Site Code : 39000010
 Start Date : 3/12/2008
 Page No : 1

Groups Printed- Trucks

Start Time	Brock St From North				Washington St From East				Lake St From South				Washington St From West				Exclu. Total	Inclu. Total	Int. Total	
	Left	Thru	Right	Peds	Left	Thru	Right	Peds	Left	Thru	Right	Peds	Left	Thru	Right	Peds				
07:00	0	0	0	0	0	7	1	0	1	0	0	0	0	6	0	0	0	0	15	15
07:15	0	0	0	0	0	8	0	0	0	1	0	0	1	4	0	0	0	0	14	14
07:30	0	0	0	0	0	8	0	0	2	1	2	0	0	9	0	0	0	0	22	22
07:45	0	0	0	0	0	11	0	0	0	0	0	0	0	4	0	0	0	0	15	15
Total	0	0	0	0	0	34	1	0	3	2	2	0	1	23						

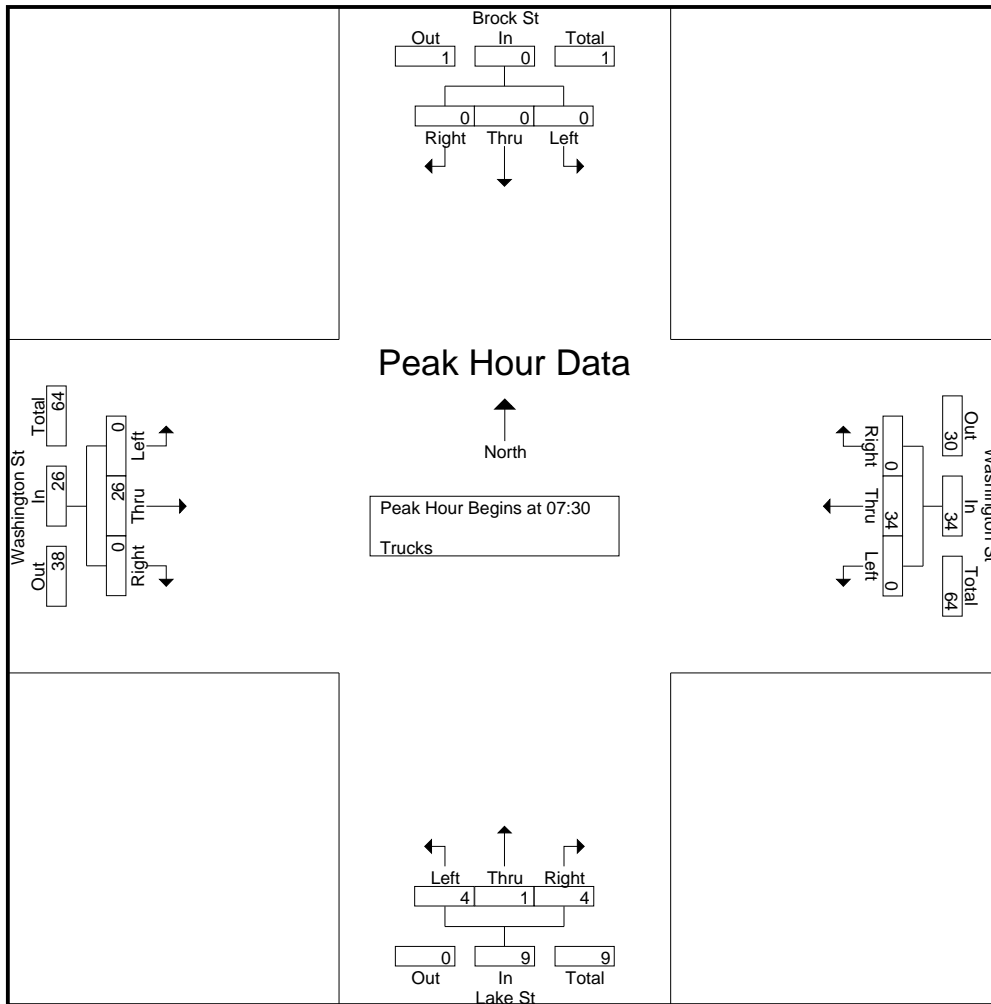

Accurate Counts
978-664-2565

File Name : 39000010
Site Code : 39000010
Start Date : 3/12/2008
Page No : 3

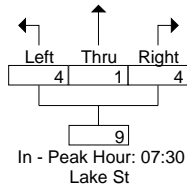
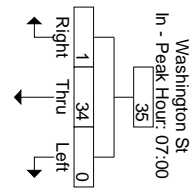
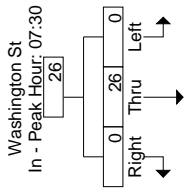
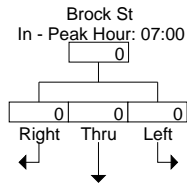

N/S Street : Brock St / s9 Ts (Site Code) Tj

Accurate Counts
978-664-2565

File Name : 39000010
Site Code : 39000010
Start Date : 3/12/2008
Page No : 1

Accurate Counts
978-664-2565

File Name : 39000010
Site Code

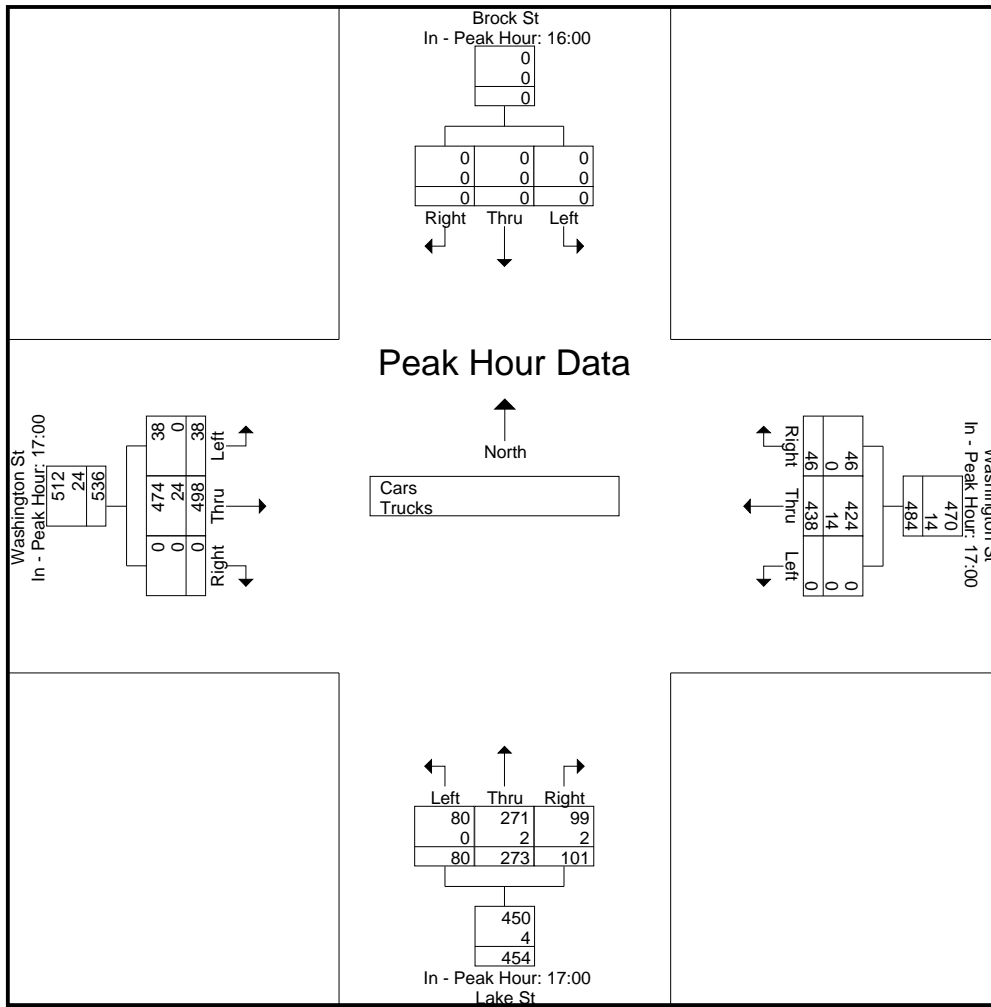

N/S Street : Brock St / Lake St
 E/W Street: Washington Street
 City/State : Brighton, MA
 Weather : Rain

Accurate Counts
 978-664-2565

File Name : 39000010
 Site Code : 39000010
 Start Date : 3/12/2008
 Page No : 1

Groups Printed- Cars

Start Time	Brock St From North				Washington St From East				Lake St From South				Washington St From West				Exclu. Total	Inclu. Total	Int. Total
	Left	Thru	Right	Peds	Left	Thru	Right	Peds	Left	Thru	Right	Peds	Left	Thru	Right	Peds			
16:00	0	0	0	7	0	94	4	2	22	64	33	9	2	89	0	0	186582.308	ET	326576.16
16:15	0	0	0	7	0	91	6	1	16	55	33	7	1	91	0	8	23	293	316
16:30	0	0	0	7	0	106	14	0	20	48	25	15	11	119	0	16	38	343	381
16:45	0	0	0	4	0	79	8	1	18	60	25	9	12	122	0	13	27	324	351
Total	0	0	0	25	0	370	32	4	76	227	116	40	26	421	0	116			

658268 60BT 18 609.T 54.98 m 385 -8 Ts5268 60BT 18 609.T 54.98 m 82. Tsj 268 60T 82. Tsj 1 B2065ET 35. Tsl 268 60BT 18 609.T 54.98 m 385206591.268 60BT 1

Accurate Counts
978-664-2565

File Name : 39000010
Site Code : 39000010
Start Date : 3/12/2008
Page No : 3

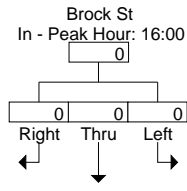

Washington St

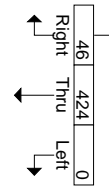

Washington St

Lake St

N/S Street : Brock St / Lake St
 E/W Street: Washington Street
 City/State : Brighton, MA
 Weather : Rain

Accurate Counts
 978-664-2565

File Name : 39000010
 Site Code : 39000010
 Start Date : 3/12/2008
 Page No : 1

Groups Printed- Trucks

Start Time	Brock St From North				Washington St From East				Lake St From South				Washington St From West				Exclu. Total	Inclu. Total	Int. Total
	Left	Thru	Right	Peds	Left	Thru	Right	Peds	Left	Thru	Right	Peds	Left	Thru	Right	Peds			
16:00	0	0	0	0	0	3	1	0	0	0	1	0	0	5	0	0	0	10	10
16:15	0	0	0	0	0	4	0	0	2	0	0	0	0	5	0	0	0	11	11
16:30	0	0	0	0	0	2	0	0	0	0	1	0	0	5	0	0	0	8	8
16:45	0	0	0	0	0	7	0	0	1	1	0	0	0	7	0	0	0	16	16
Total	0	0	0	0	0	16	1	0	3	1	2	0	0	22	0	0	0	45	45
17:00	0	0	0	0	0	4	0	0	0	0	0	0	0	7	0	0	0	11	11
17:15	0	0	0	0	0	2	0	0	0	1	0	0	0	6	0	0	0	9	9
17:30	0	0	0	0	0	4	0	0	0	1	0	0	0	5	0	0	0	10	10
17:45	0	0	0	0	0	4	0	0	0	0	2	0	0	6	0	0	0	12	12
Total	0	0	0	0	0	14	0	0	0	2	2	0	0	24	0	0	0	42	42
Grand Total	0	0	0	0	0	30	1	0	3	3	4	0	0	46	0	0	0	87	87
Apprch %	0	0	0		0	96.8	3.2		30	30	40		0	100	0				
Total %	0	0	0		0	34.5	1.1		3.4	3.4	4.6		0	52.9	0		0	100	

Start Time	Brock St From North				Washington St From East				Lake St From South				Washington St From West				Int. Total
	Left	Thru	Right	App. Total	Left	Thru	Right	App. Total	Left	Thru	Right	App. Total	Left	Thru	Right	App. Total	

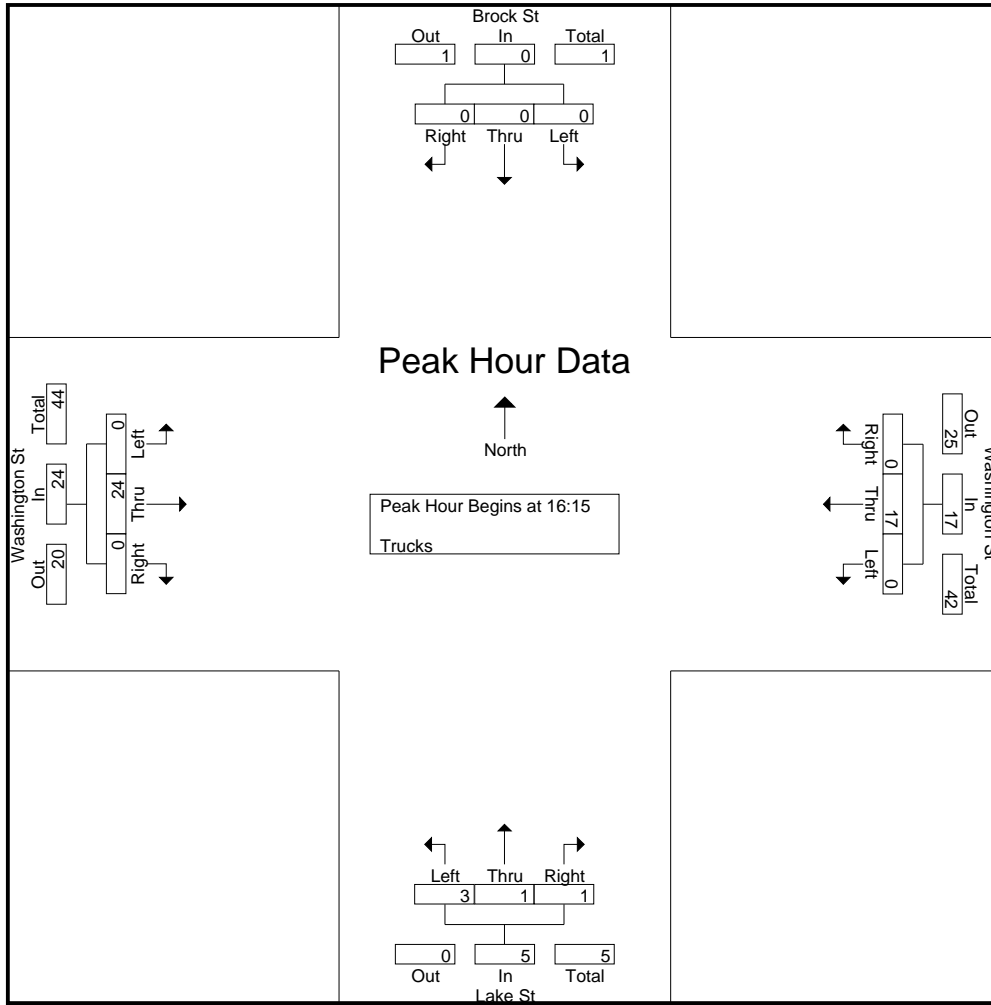

Peak Hour Analysis From 16:00 to 17:45 - Peak 1 of 1

Peak Hour for Each Approach Begins at:

	16:00				16:00				16:00				16:30			
+0 mins.	0	0	0	0	0	3	1	4	0	0	1	1	0	5	0	5
+15 mins.	0	0	0	0	0	4	0	4	2	0	0	2	0	7	0	7
+30 mins.	0	0	0	0	0	2	0	2	0	0	1	1	0	7	0	7
+45 mins.	0	0	0	0	0	7	0	7	1	1	0	2	0	6	0	6
Total Volume	0	0	0	0	0	16	1	17	3	1	2	6	0	25	0	25
% App. Total	0	0	0	0	0	94.1	5.9		50	16.7	33.3		0	100	0	
PHF	.000	.000	.000	.000	.000	.571	.250	.607	.375	.250	.500	.750	.000	.893	.000	.893

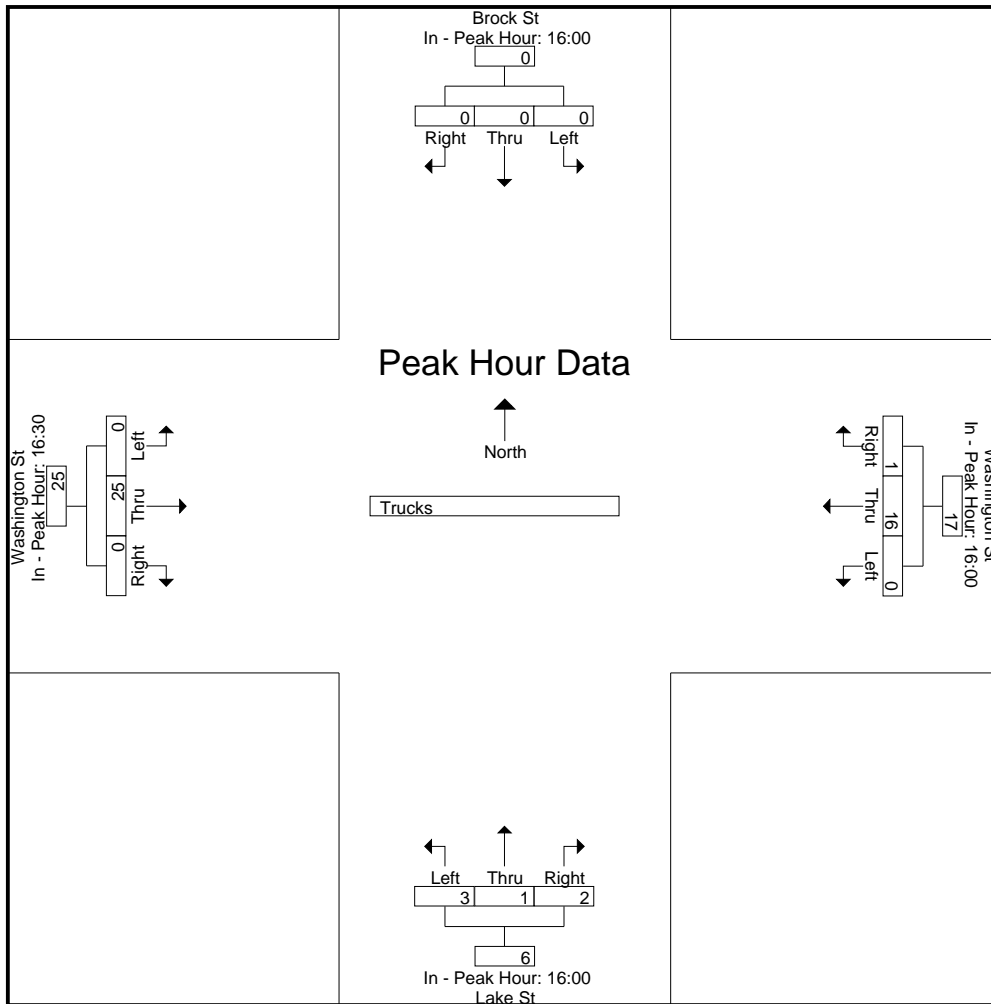

Accurate Counts
978-664-2565

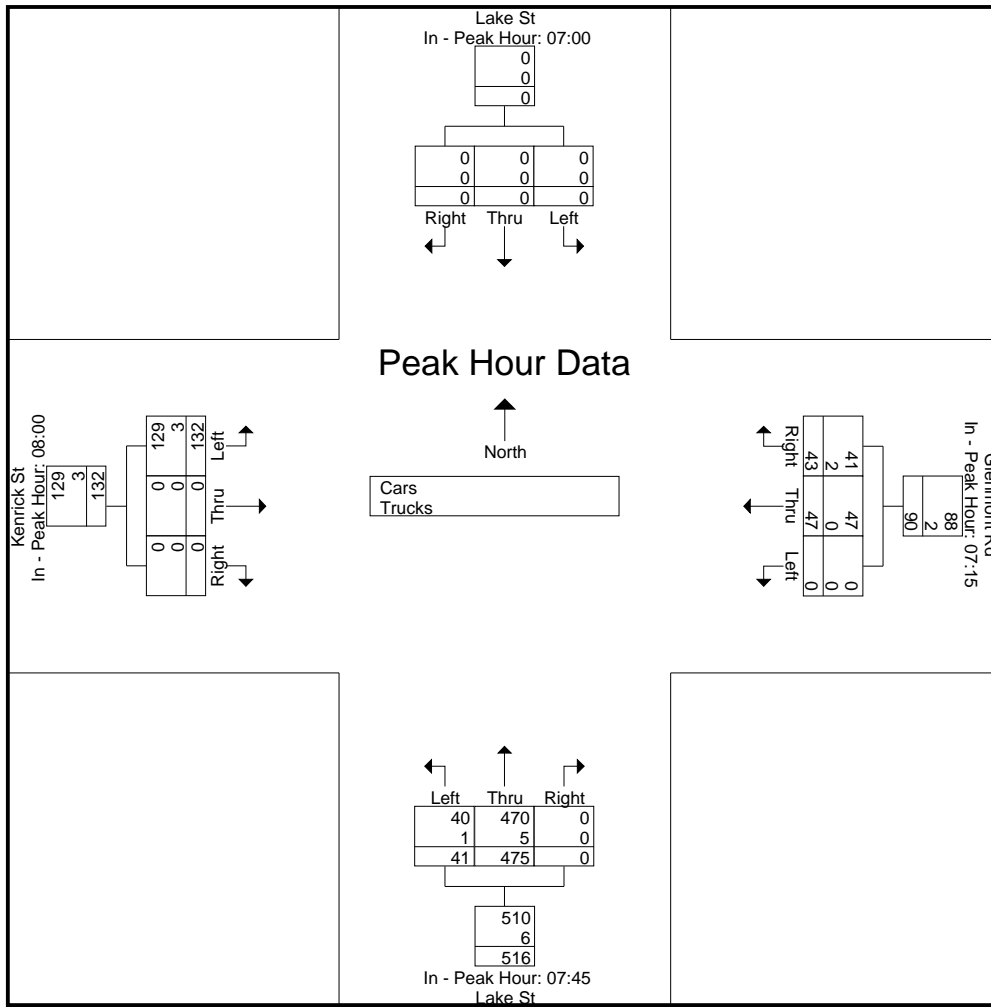

Accurate Counts
978-664-2565

File Name : 39000011
Site Code

N/S Street : Lake Street
 E/W Street: Kenrick St / Glenmont Rd
 City/State : Brighton, MA
 Weather : Rain

Accurate Counts
 978-664-2565

File Name : 39000011
 Site Code : 39000011
 Start Date : 3/12/2008
 Page No : 1

Groups Printed- Trucks

Start Time	Lake St From North				Glenmont Rd From East				Lake St From South				Kenrick St From West				Exclu. Total	Inclu. Total	Int. Total
	Left	Thru	Right	Peds	Left	Thru	Right	Peds	Left	Thru	Right	Peds	Left	Thru	Right	Peds			
07:00	0	0	0	0	0	0	1	0	0	1	0	0	0	0	0	0	0	2	2
07:15	0	0	0	0	0	0	0	0	0	0	0	0	0	0	0	0	0	0	0
07:30	0	0	0	0	0	0	2	0	0	3	0	0	0	0	0	0	0	5	5
07:45	0	0	0	0	0	0	0	0	0	0	0	0	0	0	0	0	0	0	0
Total	0	0	0	0	0	0	3	0	0	4	0	0	0	0	0	0	0	7	7
08:00	0	0	0	0	0	0	0	0	0	1	0	0	1	0	0	0	0	2	2
08:15	0	0	0	0	0	0	0	0	1	3	0	0	1	0	0	0	0	5	5
08:30	0	0	0	0	0	1	1	0	0	1	0	0	1	0	0	0	0	4	4
08:45	0	0	0	0	0	0	0	0	0	0	0	0	0	0	0	0	0	0	0
Total	0	0	0	0	0	1	1	0	1	5	0	0	3	0	0	0	0	11	11
Grand Total	0	0	0	0	0	1	4	0	1	9	0	0	3	0	0	0	0	18	18
Apprch %	0	0	0		0	20	80		10	90	0		100	0	0				
Total %	0	0	0		0	5.6	22.2		5.6	50	0		16.7	0	0		0	100	

Start Time	Lake St From North				Glenmont Rd From East				Lake St From South				Kenrick St From West				Int. Total
	Left	Thru	Right	App. Total	Left	Thru	Right	App. Total	Left	Thru	Right	App. Total	Left	Thru	Right	App. Total	
Peak Hour Analysis From 07:00 to 08:45 - Peak 1 of 1																	
Peak Hour for Entire Intersection Begins at 07:30																	
07:30	0	0	0	0	0	0	2	2	0	3	0	3	0	0	0	0	5
07:45	0	0	0	0	0	0	0	0	0	0	0	0	0	0	0	0	0
08:00	0	0	0	0	0	0	0	0	0	1	0	1	1	0	0	1	2
08:15	0	0	0	0	0	0	0	0	1	3	0	4	1	0	0	1	5
Total Volume	0	0	0	0	0	0	2	2	1	7	0	8	2	0	0	2	12
% App. Total	0	0	0		0	0	100		12.5	87.5	0		100	0	0		
PHF	.000	.000	.000	.000	.000	.000	.250	.250	.250	.583	.000	.500	.500	.000	.000	.500	.600

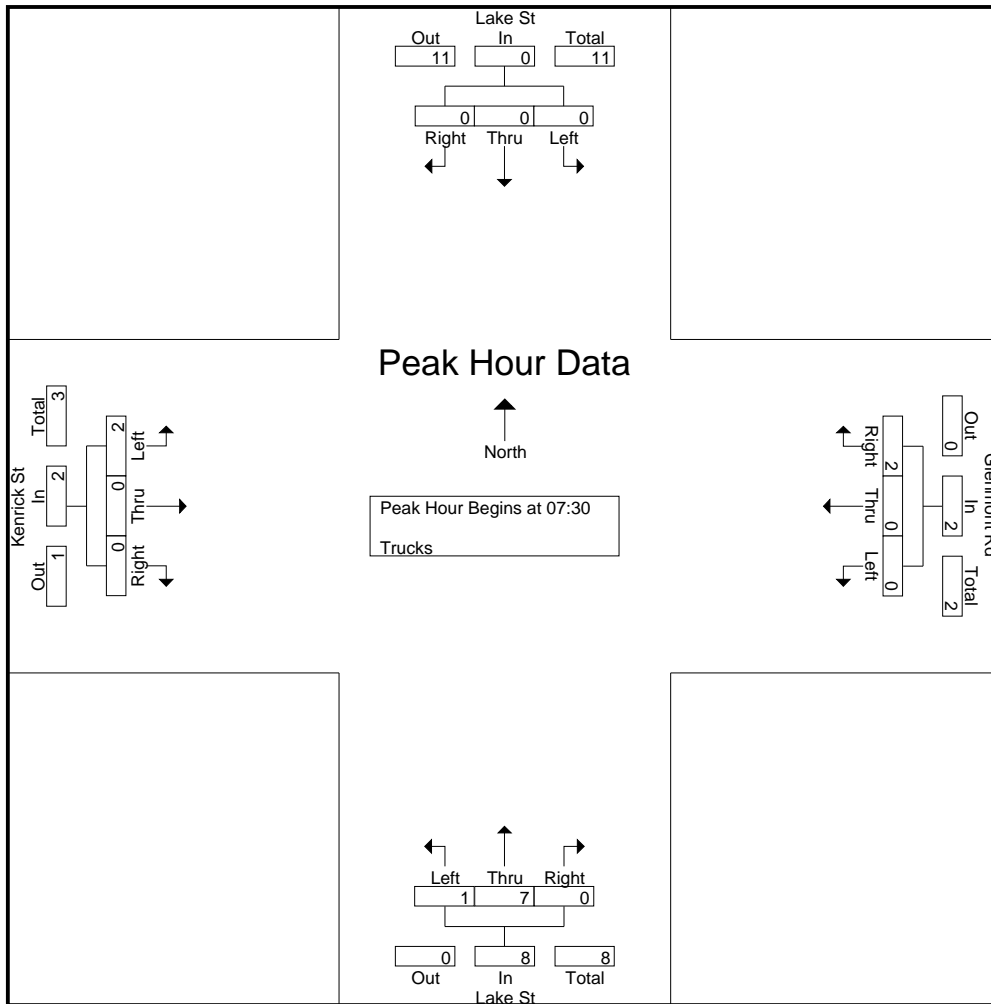

Peak Hour Analysis From 07:00 to 08:45 - Peak 1 of 1
Peak Hour for Each ApG Peak BT 17.88 314f0

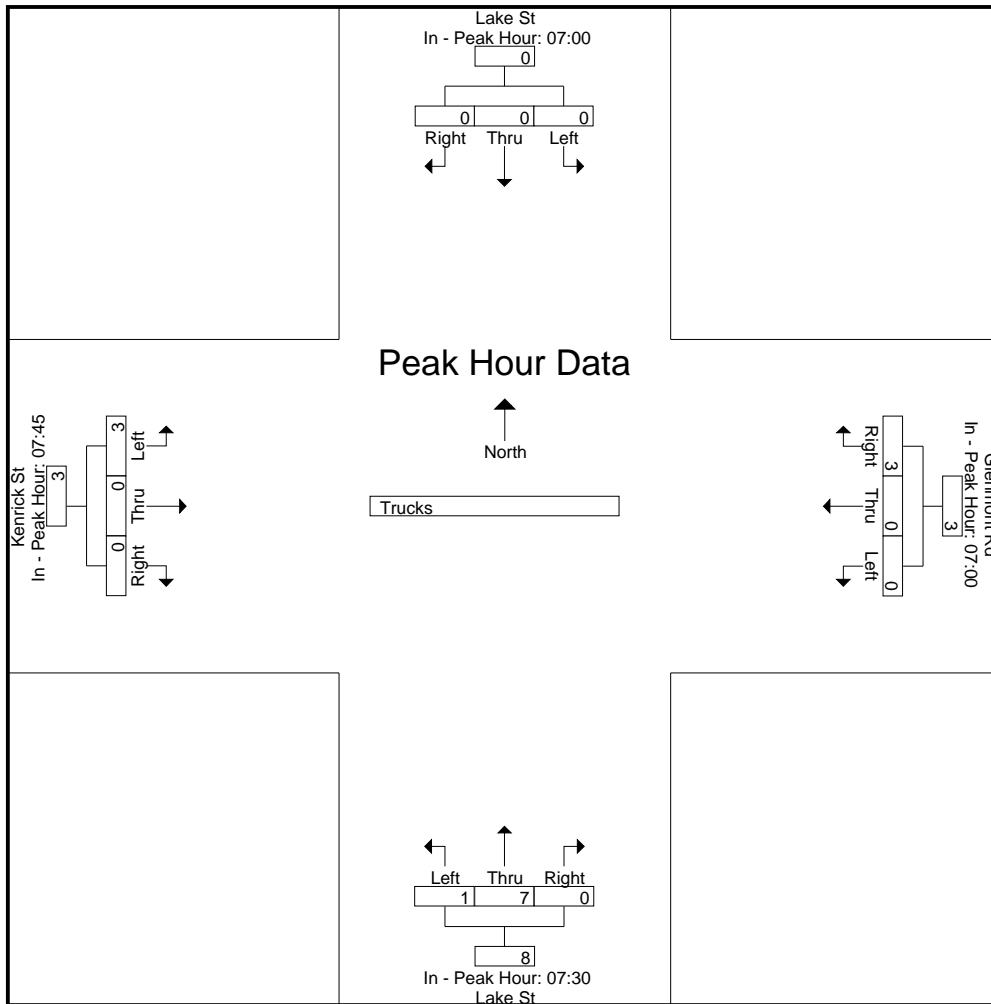

Accurate Counts

Accurate Counts
978-664-2565

File Name : 39000011
Site Code : 39000011
Start Date : 3/12/2008
Page No : 3

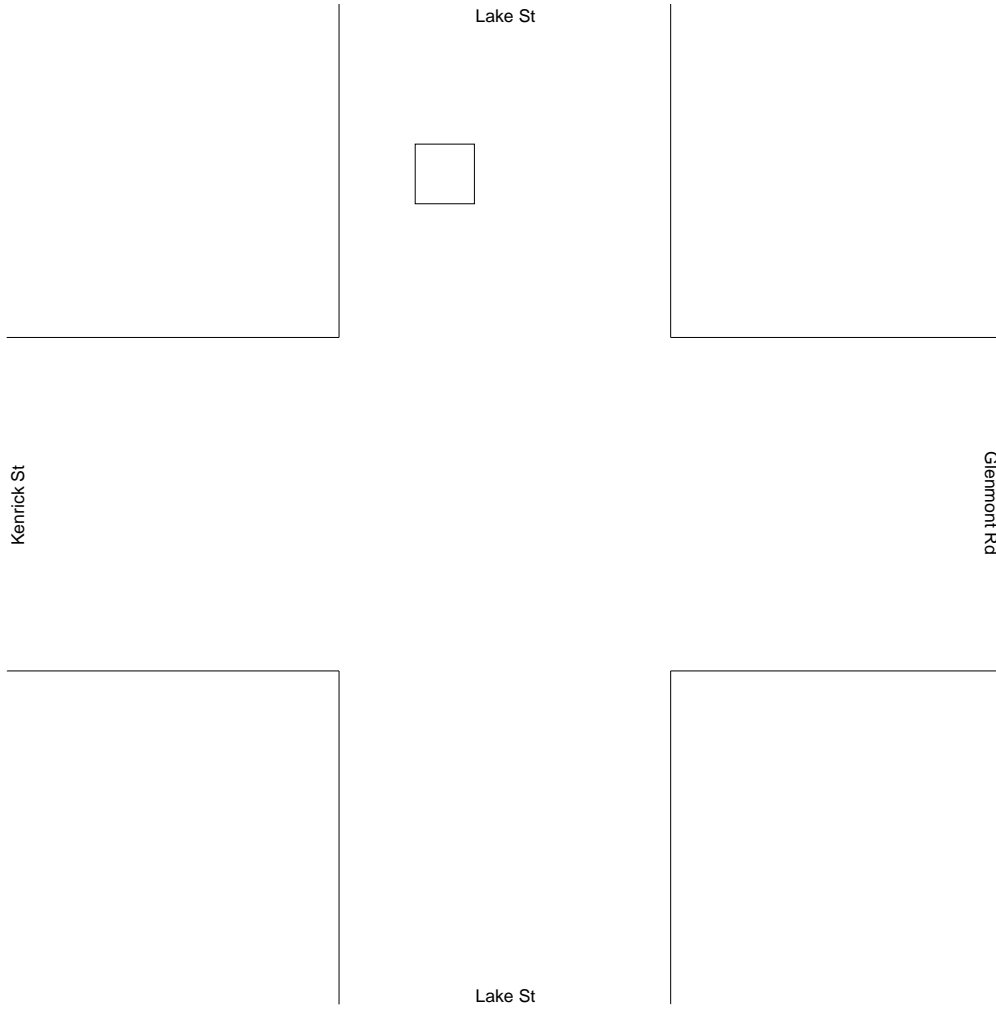

Accurate Counts
978-664-2565

Accurate Counts
978-664-2565

File Name : 39000011
Site Code : 39000011
Start Date : 3/12/2008
Page No : 3

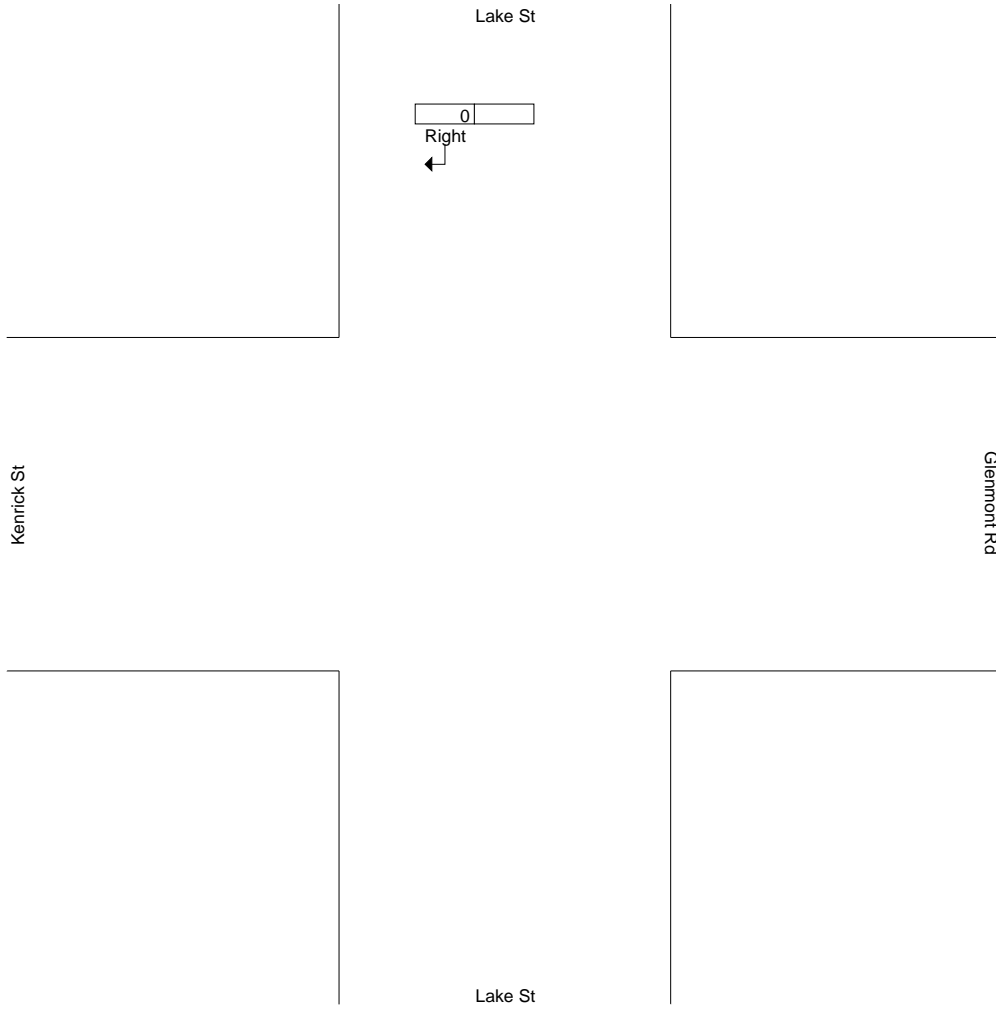

N/S Street : Lake Street
E/W Street: Kenrick St / Glenmont Rd

Accurate Counts
978-664-2565

File Name : 39000011
Site Code : 39000011
Start Date : 3/12/2008
Page No : 1

Accurate Counts
978-664-2565

File Name : 39000011
Site Code : 39000011
Start Date : 3/12/2008
Page No : 2

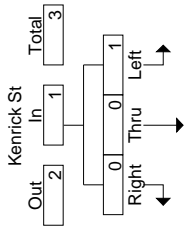
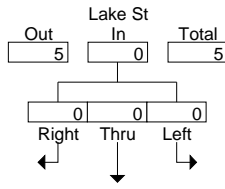

G8 515.74 Td -6.61 Ts (G8 515.74 Td -6.61 /F15 k Hour 6 Tm -6.61 Ts)

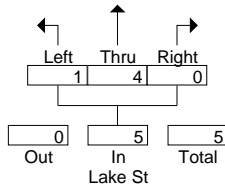
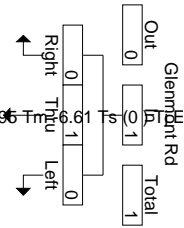

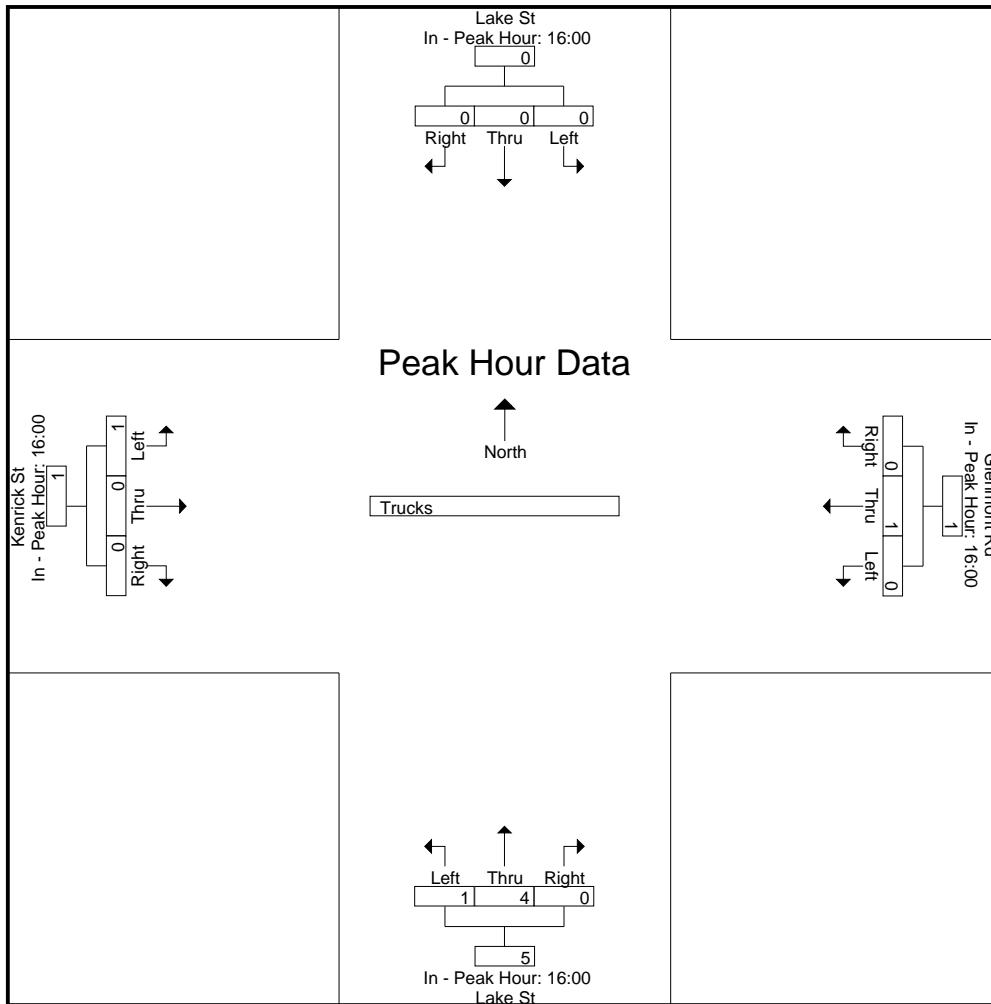

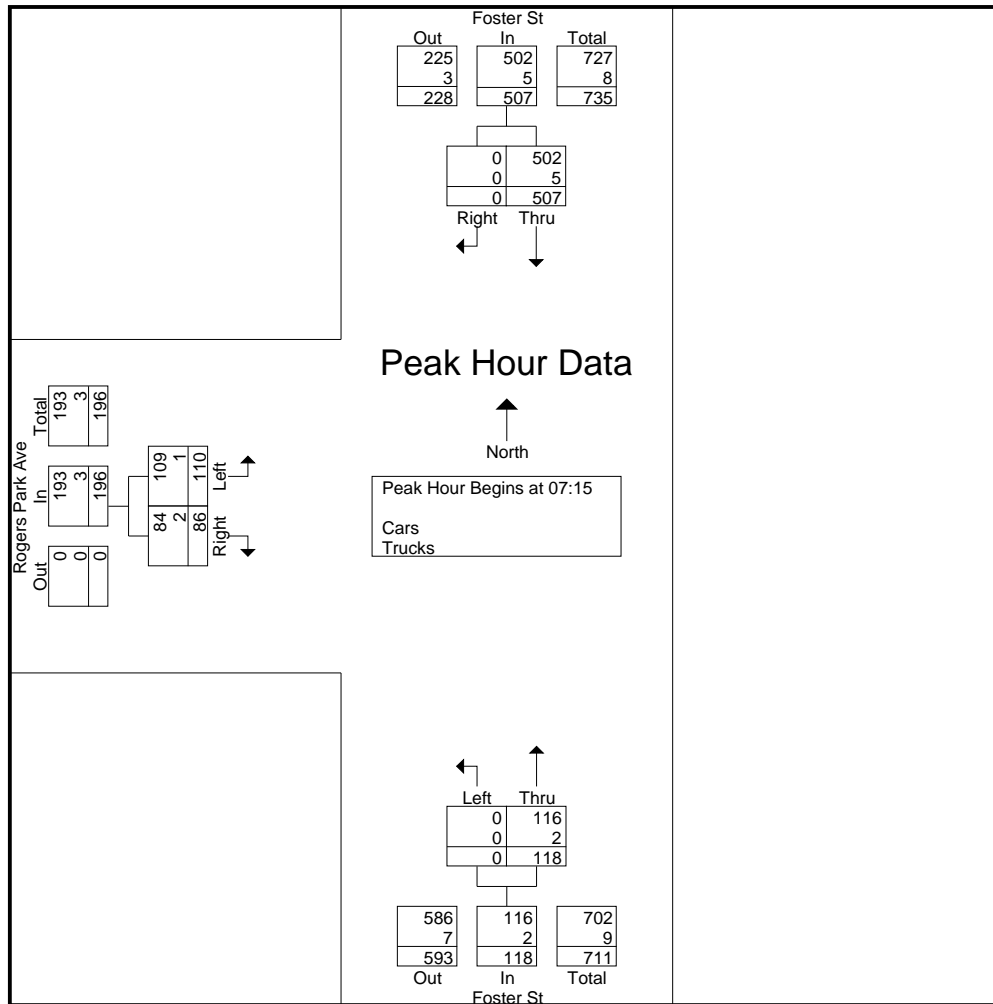

Peak Hour Analysis From 07:00 to 08:45 - Peak 1 of 1

Peak Hour for Each Approach Begins at:

	07:15			07:45			07:15		
+0 mins.	132	0	132	0	34	34	32	22	54
+15 mins.	128	0	128	0	37	37	21	23	44
+30 mins.	115	0	115	0	33	33	24	23	47
+45 mins.	132	0	132	0	30	30	33	18	51
Total Volume	507	0	507	0	134	134	110	86	196
% App. Total	100	0		0	100		56.1	43.9	
PHF	.960	.000	.960	.000	.905	.905	.833	.935	.907
Cars	502	0	502	0	133	133	109	84	193
% Cars	99	0	99	0	99.3	99.3	99.1	97.7	98.5
Trucks	5	0	5	0	1	1	1	2	3
% Trucks	1	0	1	0	0.7	0.7	0.9	2.3	1.5

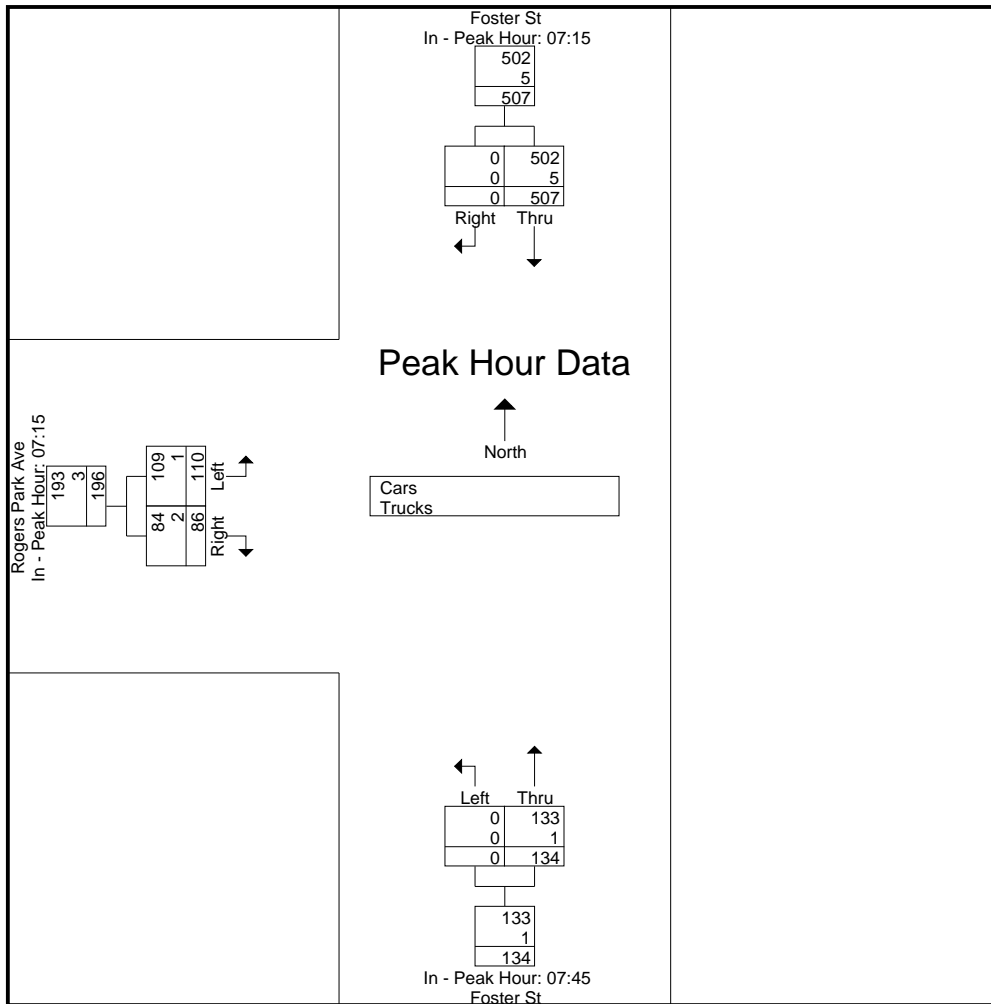

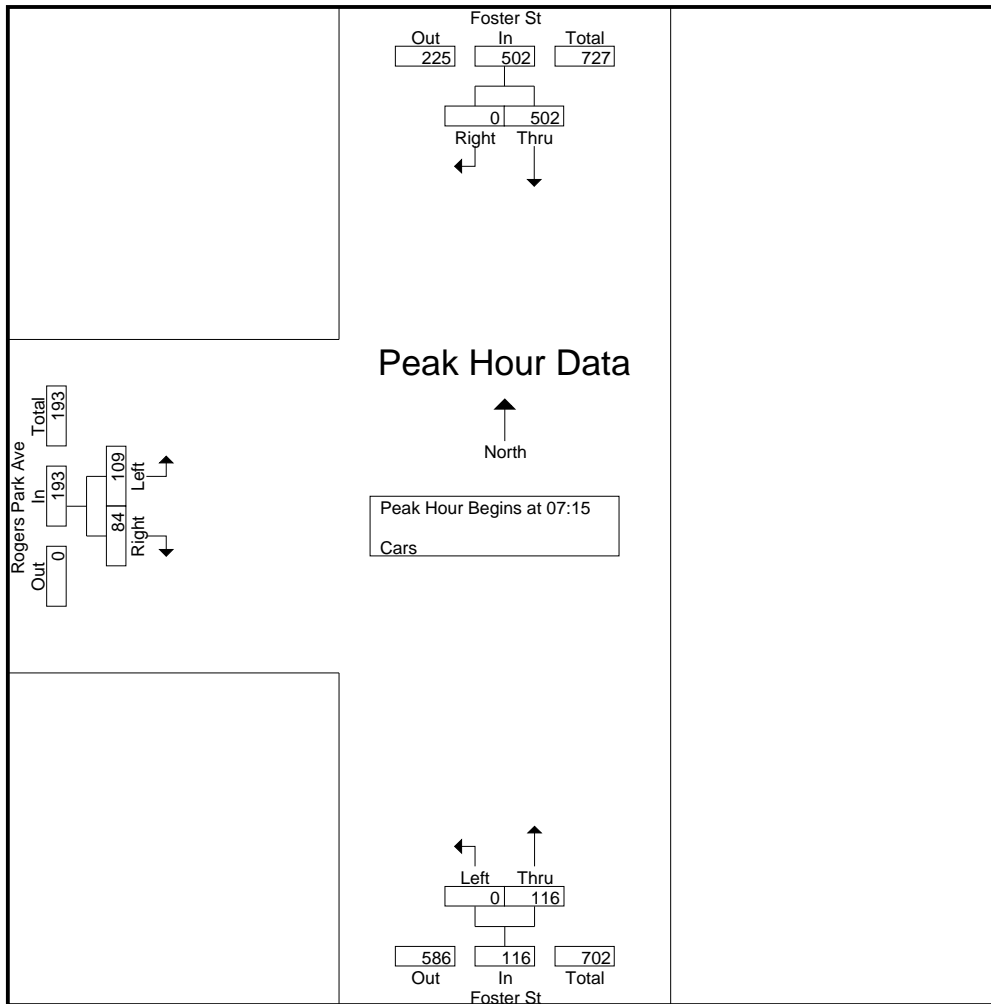

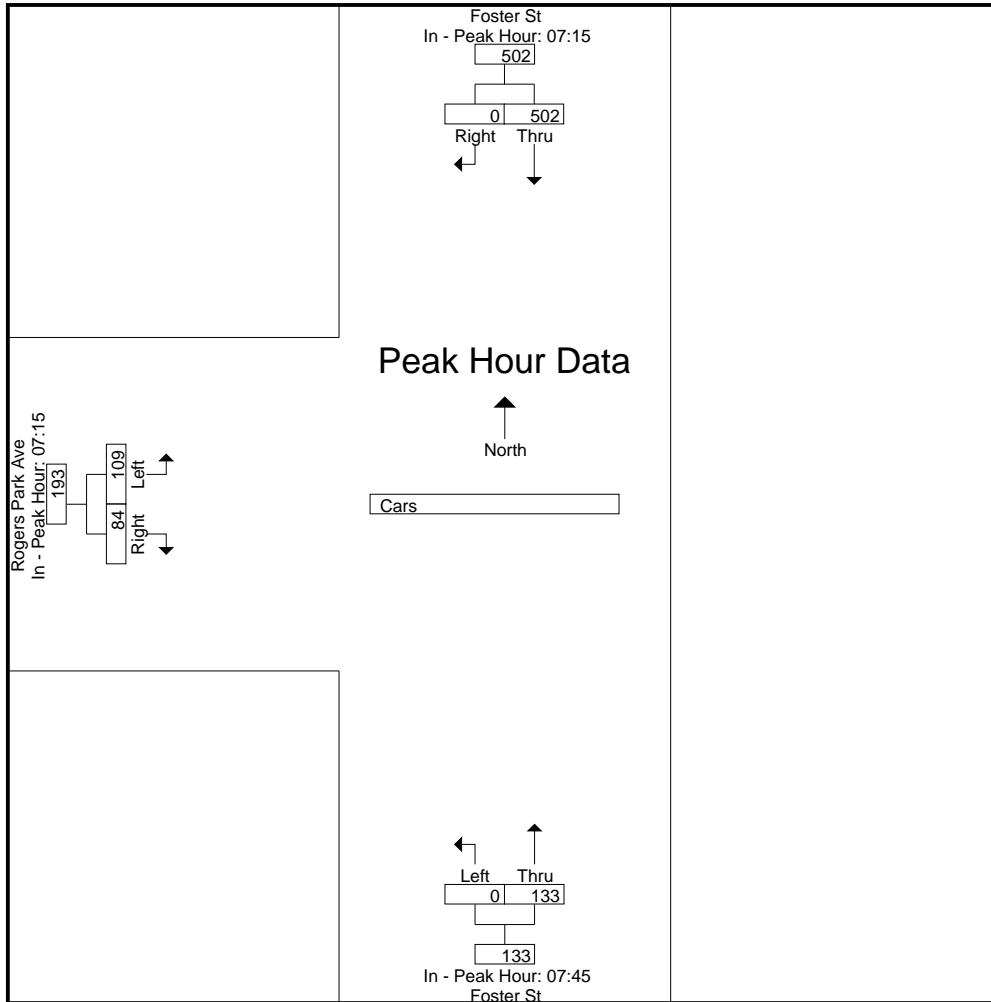

N/S Street : Foster Street
 E/W Street: Rogers Park Avenue
 City/State : Brighton, MA
 Weather : Rain

Accurate Counts
 978-664-2565

File Name : 39000012
 Site Code : 39000012
 Start Date : 3/12/2008
 Page No : 1

Groups Printed- Trucks

Start Time	Foster St From North			Foster St From South			Rogers Park Ave From West			Exclu. Total	Inclu. Total	Int. Total
	Thru	Right	Peds	Left	Thru	Peds	Left	Right	Peds			
07:00	7	0	0	0	2	0	2	0	0	0	11	11
07:15	3	0	0	0	1	0	1	2	0	0	7	7

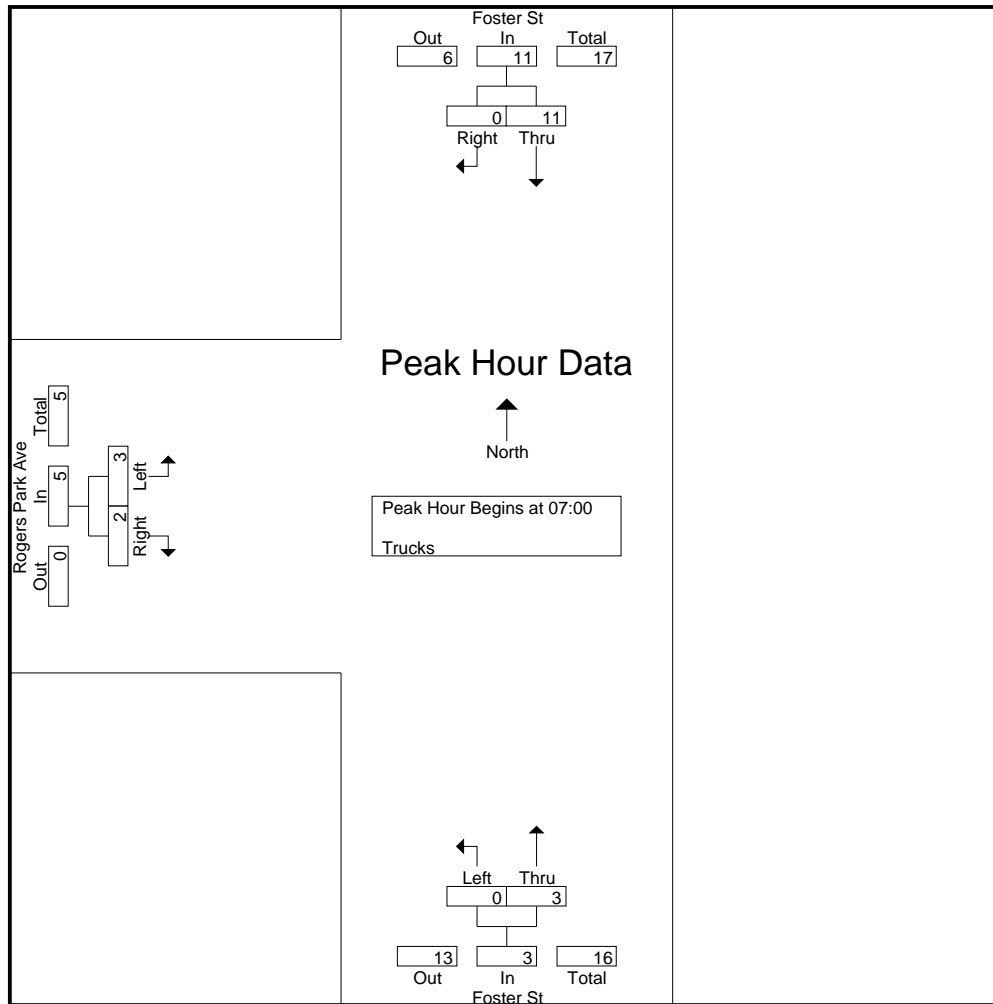

Peak Hour Analysis From 07:00 to 08:45 - Peak 1 of 1

Peak Hour for Each Approach Begins at:

	07:00			07:00			07:00		
+0 mins.	7	0	7	0	2	2	2	0	2
+15 mins.	3	0	3	0	1	1	1	2	3
+30 mins.	1	0	1	0	0	0	0	0	0
+45 mins.	0	0	0	0	0	0	0	0	0
Total Volume	11	0	11	0	3	3	3	2	5
% App. Total	100	0		0	100		60	40	
PHF	.393	.000	.393	.000	.375	.375	.375	.250	.417

Accurate Counts
978-664-2565

File Name : 39000012
Site Code : 39000012
Start Date : 3/12/2008
Page No : 3

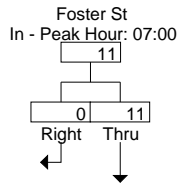

Rogers Park Ave

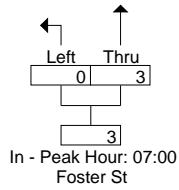
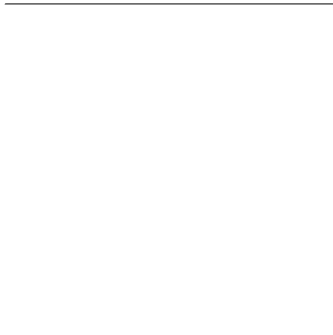

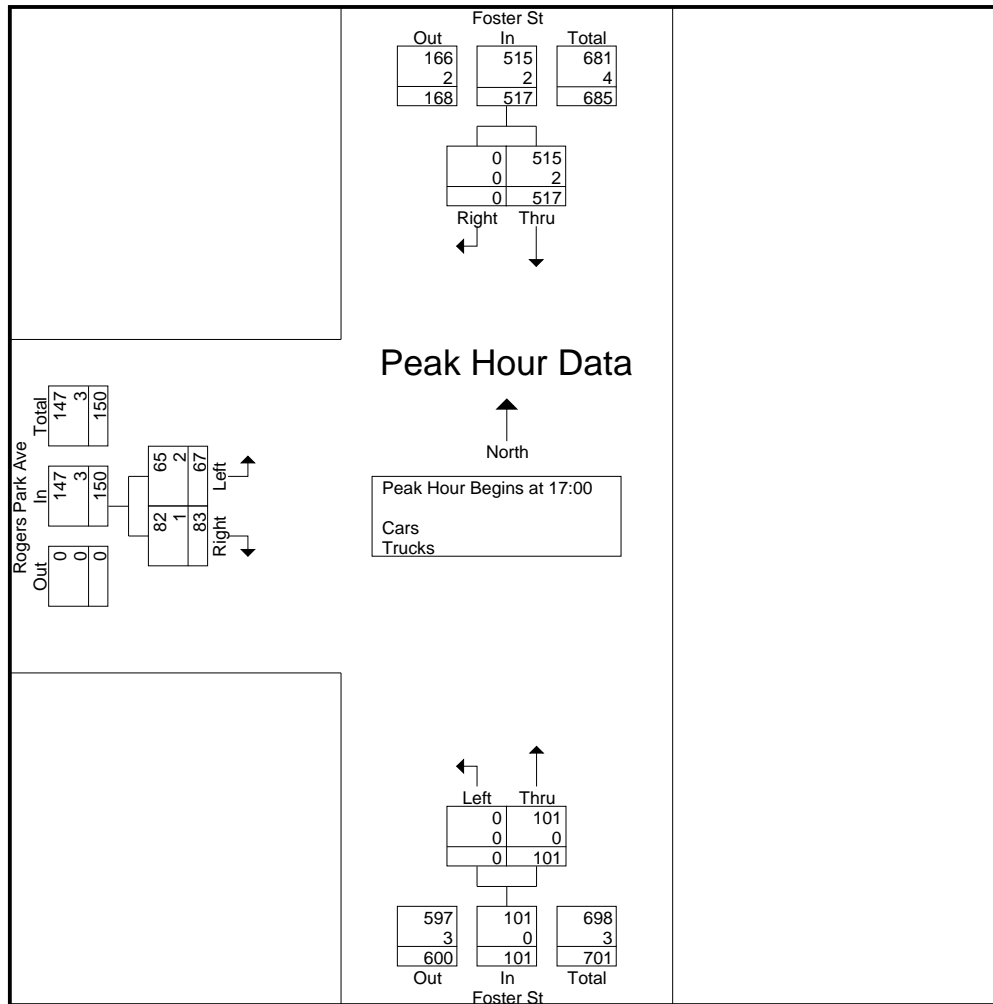

Peak Hour Analysis From 16:00 to 17:45 - Peak 1 of 1

12 322 73.44.2922 176 2 322 r for Each Ap8 324.5 373.44390s5 32 322 Q 390s5 32q 18 73.44538 532 322 Q 538 532q 18 73.44390s5 32 322 Q 538 52

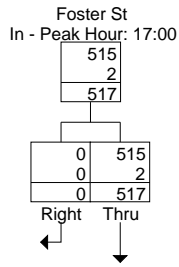

Peak Hour Data

Cars
Trucks

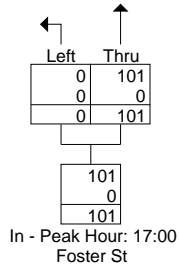
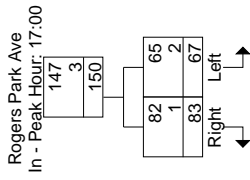

Accurate Counts
978-664-2565

File Name : 39000012
Site Code : 39000012
Start Date : 3/12/2008
Page No : 2

Foster St

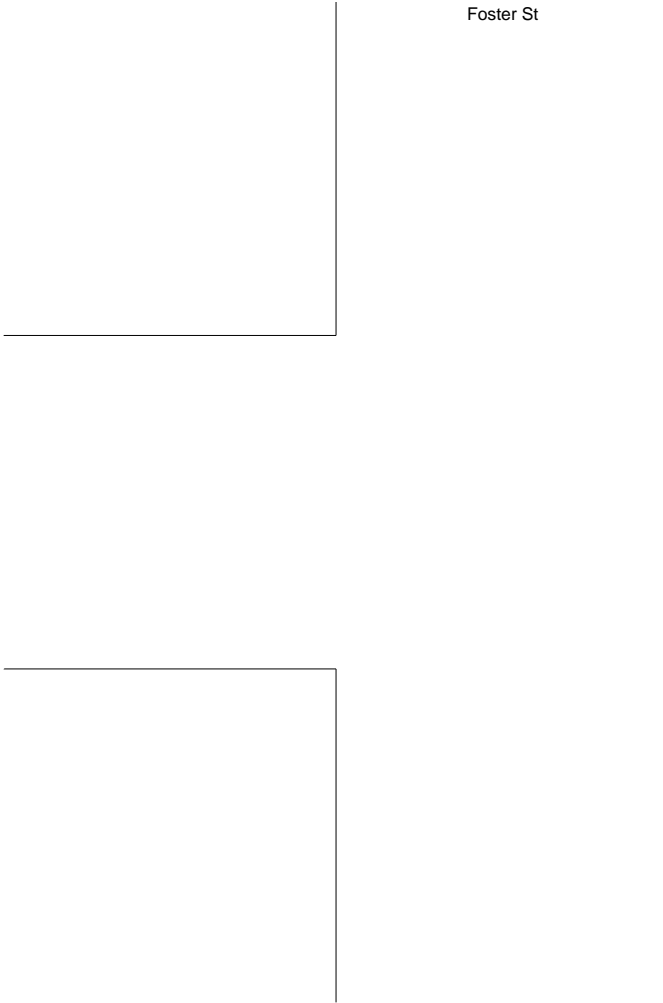

Accurate Counts
978-664-2565

File Name : 39000012
Site Code : 39000012
Start Date : 3/12/2008
Page No : 3

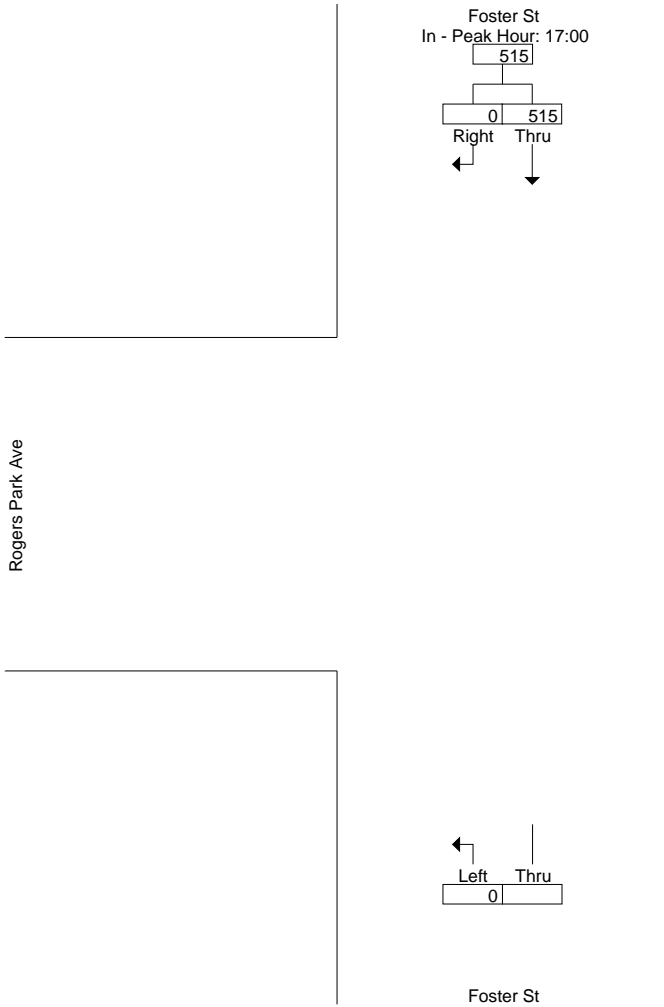

Accurate Counts
978-664-2565

File Name : 39000012
Site Code : 39000012
Start Date

Accurate Counts
978-664-2565

File Name : 39000012
Site Code : 39000012
Start Date : 3/12/2008
Page No : 2

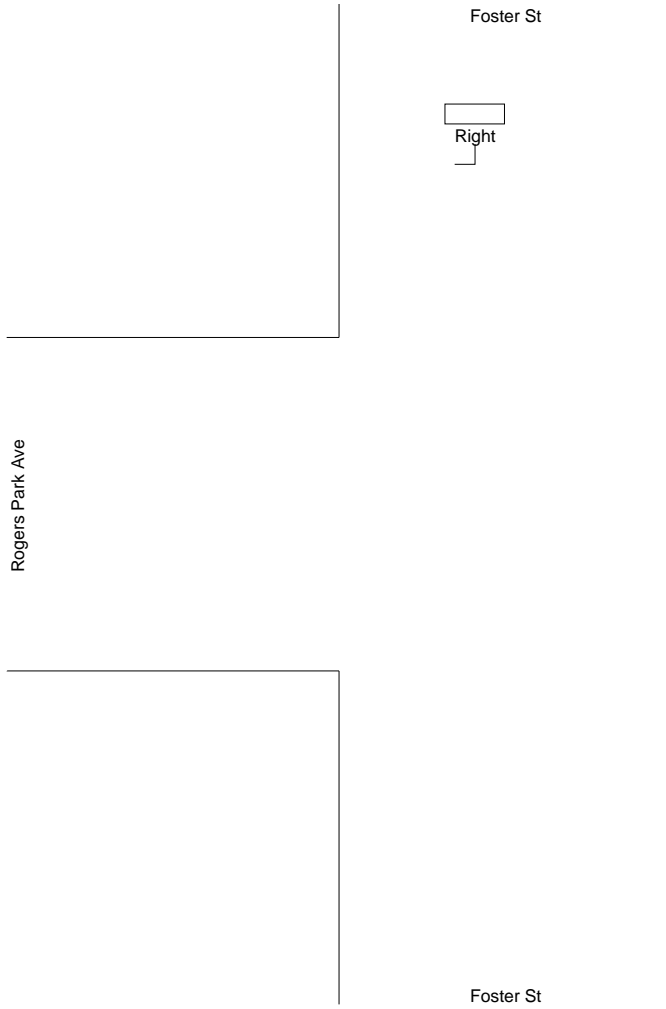

Accurate Counts
978-664-2565

File Name : 39000012
Site Code : 39000012
Start Date : 3/12/2008
Page No : 3

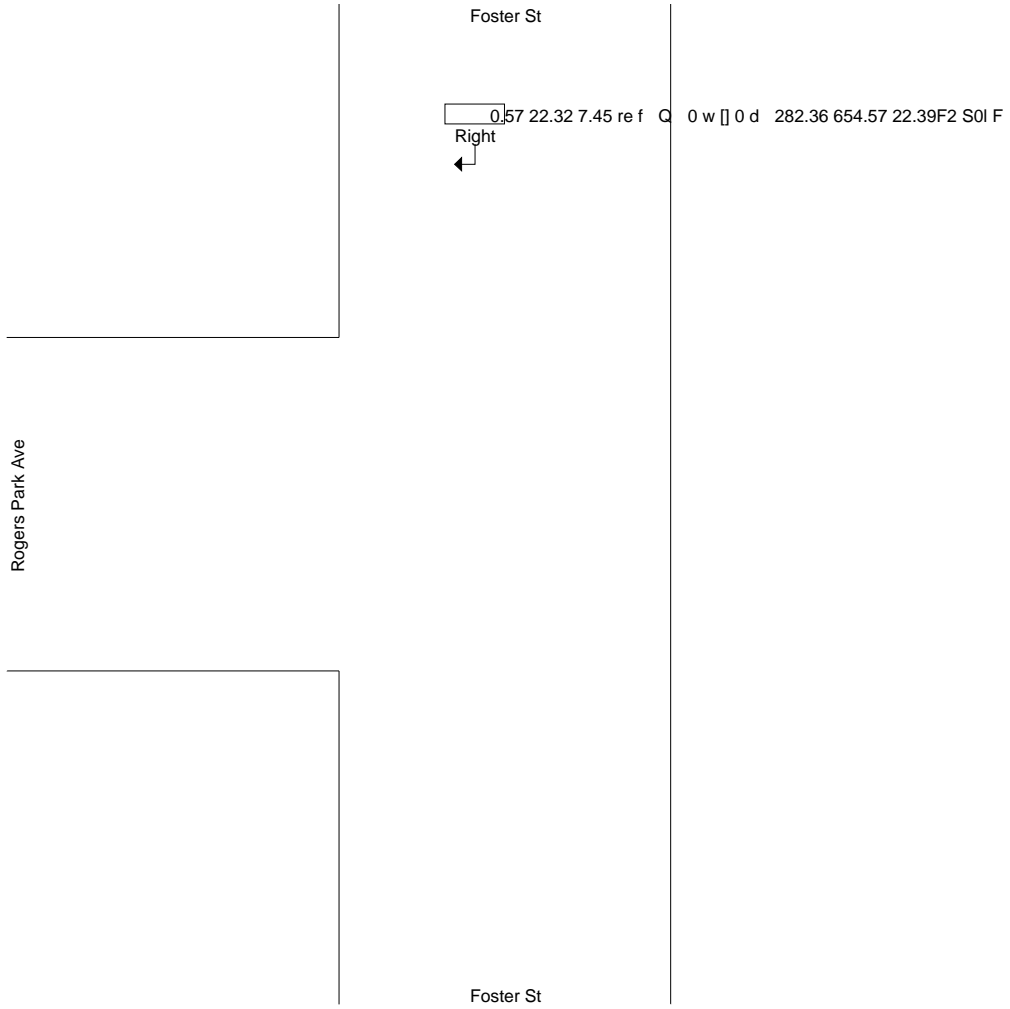

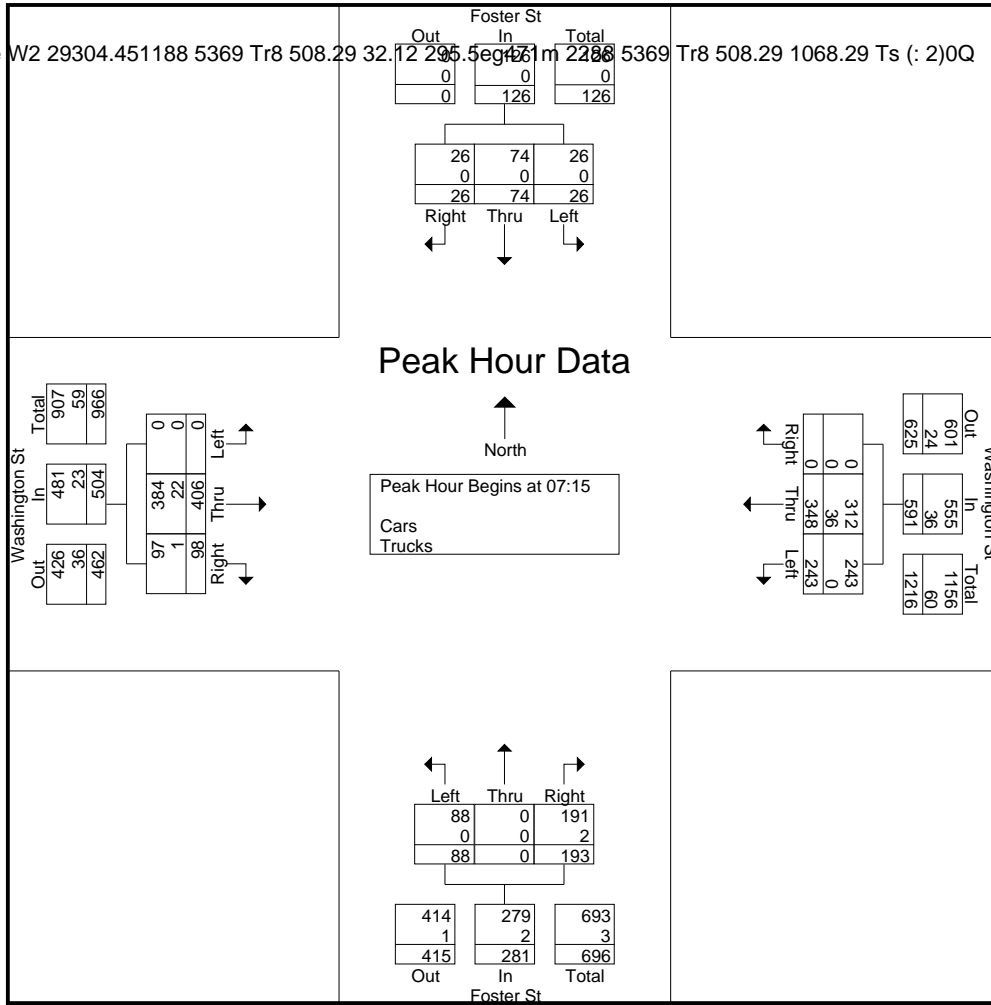

Peak Hour Analysis From 07:00 to 08:45 - Peak 1 of 1

Peak Hour for Each Approach Begins at:

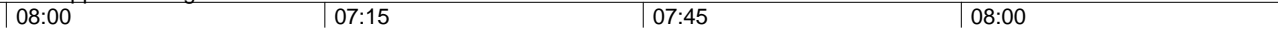

Accurate Counts
978-664-2565

Accurate Counts
978-664-2565

File Name : 39000013
Site Code : 39000013
Start Date : 3/12/2008
Page No : 2

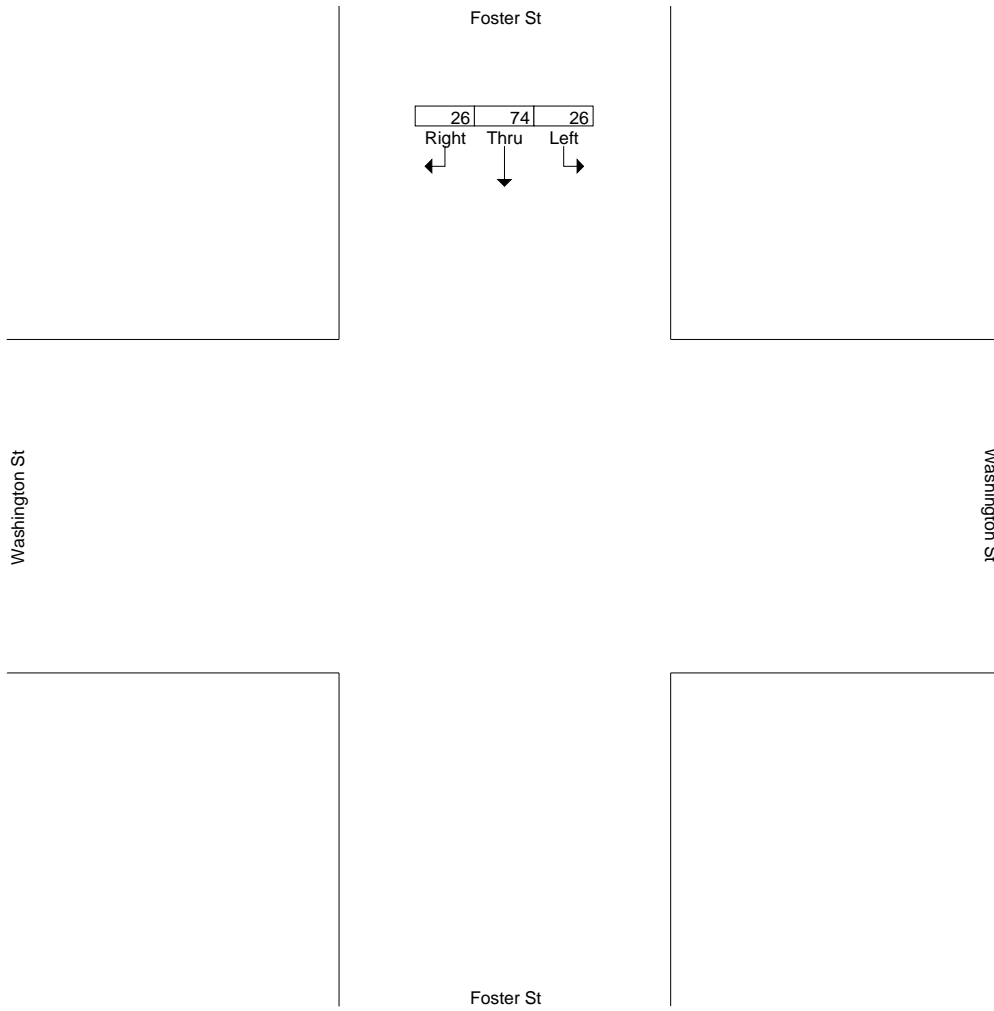

Accurate Counts
978-664-2565

File Name : 39000013
Site Code : 39000013
Start Date : 3/12/2008
Page No : 3

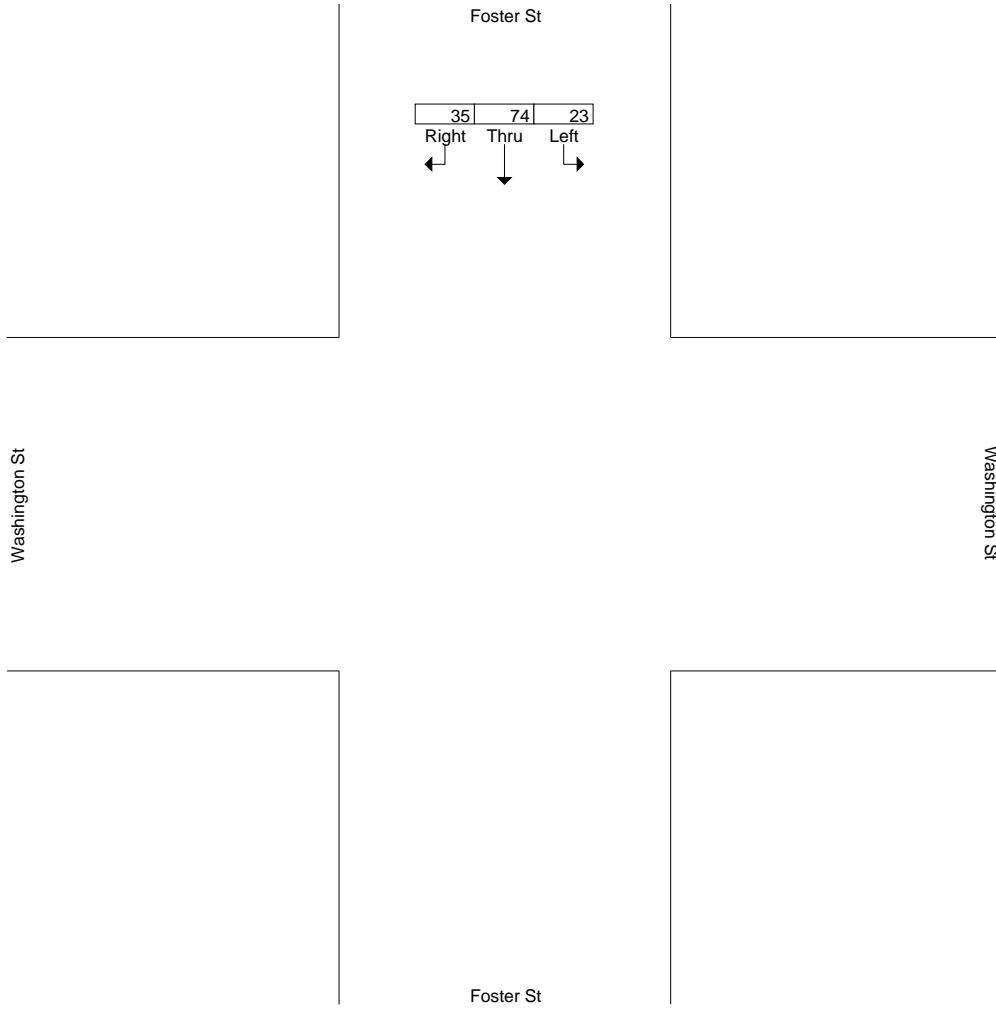

N/S Street : Foster Street
 E/W Street: Washington Street
 City/State : Brighton, MA
 Weather : Rain

Accurate Counts
 978-664-2565

File Name : 39000013
 Site Code : 39000013
 Start Date : 3/12/2008
 Page No : 1

Groups Printed- Trucks

Start Time	Foster St From North				Washington St From East				Foster St From South				Washington St From West				Exclu. Total	Inclu. Total	Int. Total
	Left	Thru	Right	Peds	Left	Thru	Right	Peds	Left	Thru	Right	Peds	Left	Thru	Right	Peds			
07:00	0	0	0	0	7	8	0	0	1	0	2	0	0	4	1	0	0	23	23
07:15	0	0	0	0	0	8	0	0	0	0	1	0	0	4	0	0	0	13	13
07:30	0	0	0	0	0	12	0	0	0	0	0	0	0	10	1	0	0	23	23
07:45	0	0	0	0	0	8	0	0	0	0	1	0	0	3	0	0	0	12	12
Total	0	0	0	0	7	36	0	0	1	0	4	0	0	21	2	0	0	71	71
08:00	0	0	0	0	0	8	0	0	0	0	0	0	0	5	0	0	0	13	13
08:15	0	0	0	0	0	6	0	0	0	0	0	0	0	7	0	0	0	13	13
08:30	0	0	0	0	0	7	0	0	0	0	0	0	0	5	1	0	0	13	13
08:45	0	0	0	0	0	6	0	0	0	0	1	0	0	6	0	0	0	13	13
Total	0	0	0	0	0	27	0	0	0	0	1	0	0	23	1	0	0	52	52
Grand Total	0	0	0	0	7	63	0	0	1	0	5	0	0	44	3	0	0	123	123
Apprch %	0	0	0		10	90	0		16.7	0	83.3		0	93.6	6.4				
Total %	0	0	0		5.7	51.2	0		0.8	0									

0

0

Accurate Counts
978-664-2565

File Name : 39000013
Site Code : 39000013
Start Date : 3/12/2008
Page No : 2

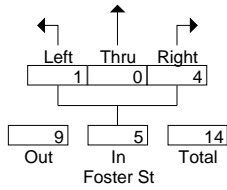
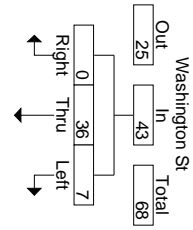
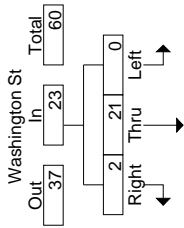
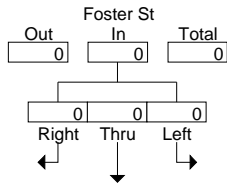

Accurate Counts
978-664-2565

File Name : 39000013
Site Code : 39000013
Start Date : 3/12/2008
Page No : 3

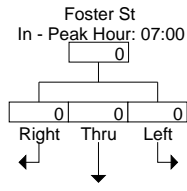

Washington St

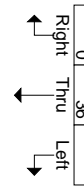

Washington St

Foster St

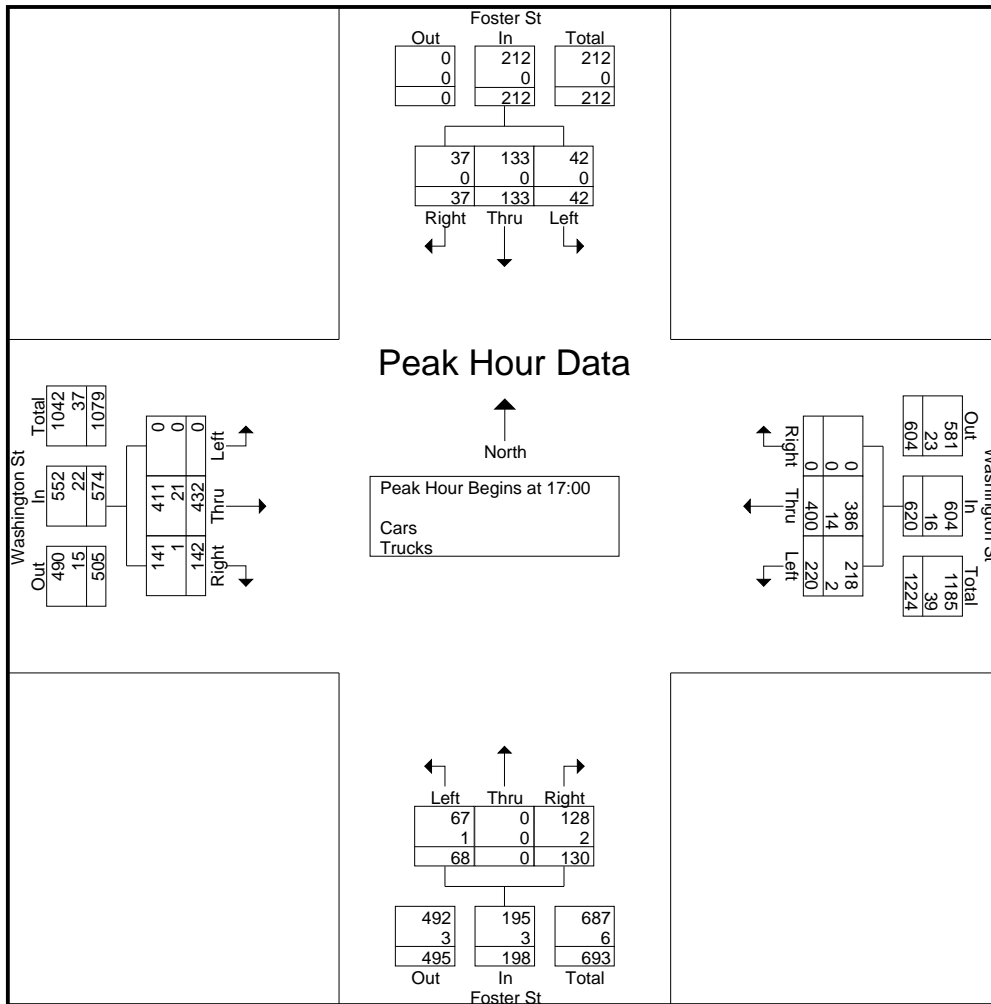

Peak Hour Analysis From 16:00 to 17:45 - Peak 1 of 1
Peak Hour for Each Approach Begins at: In 3512.92 Tm -6.61 Ts (In) Tj ET Q q 118 473.44 375 re In

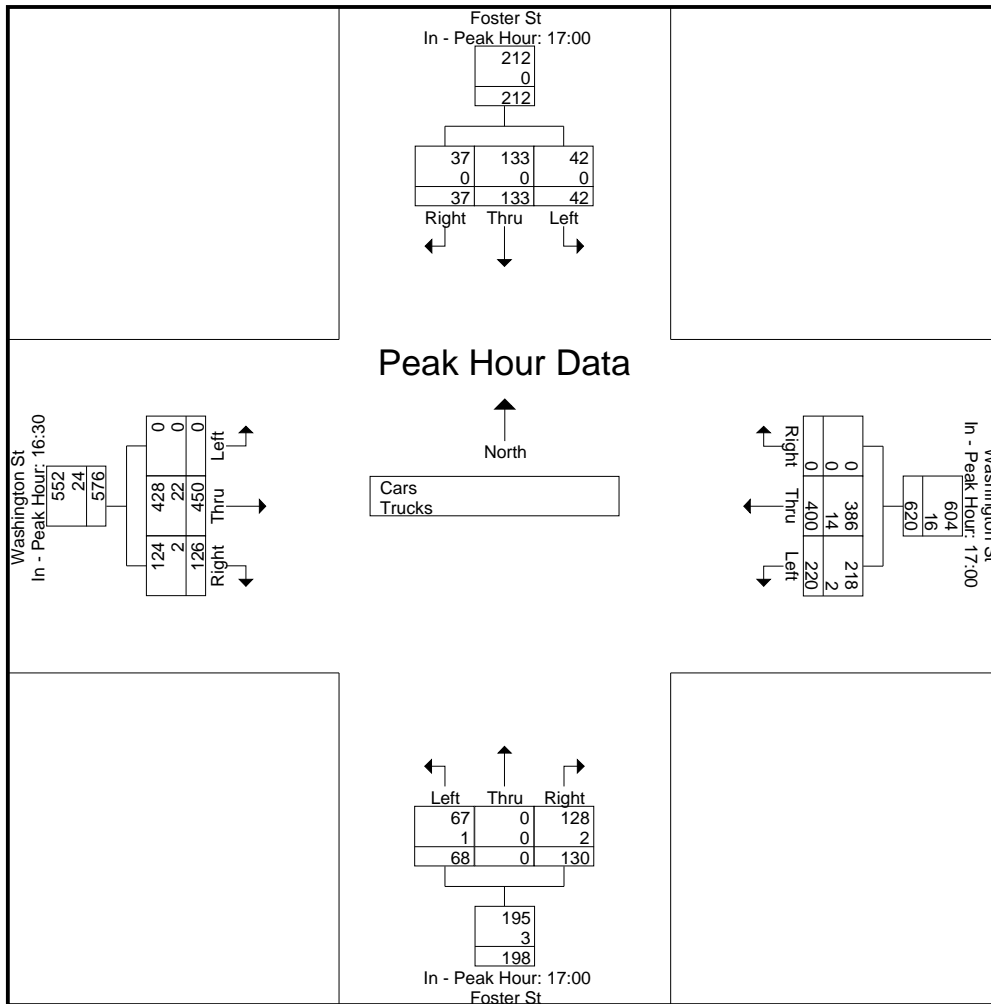

Accurate Counts
978-664-2565

File Name : 39000013
Site Code : 39000013
Start Date : 3/12/2008
Page No : 2Total

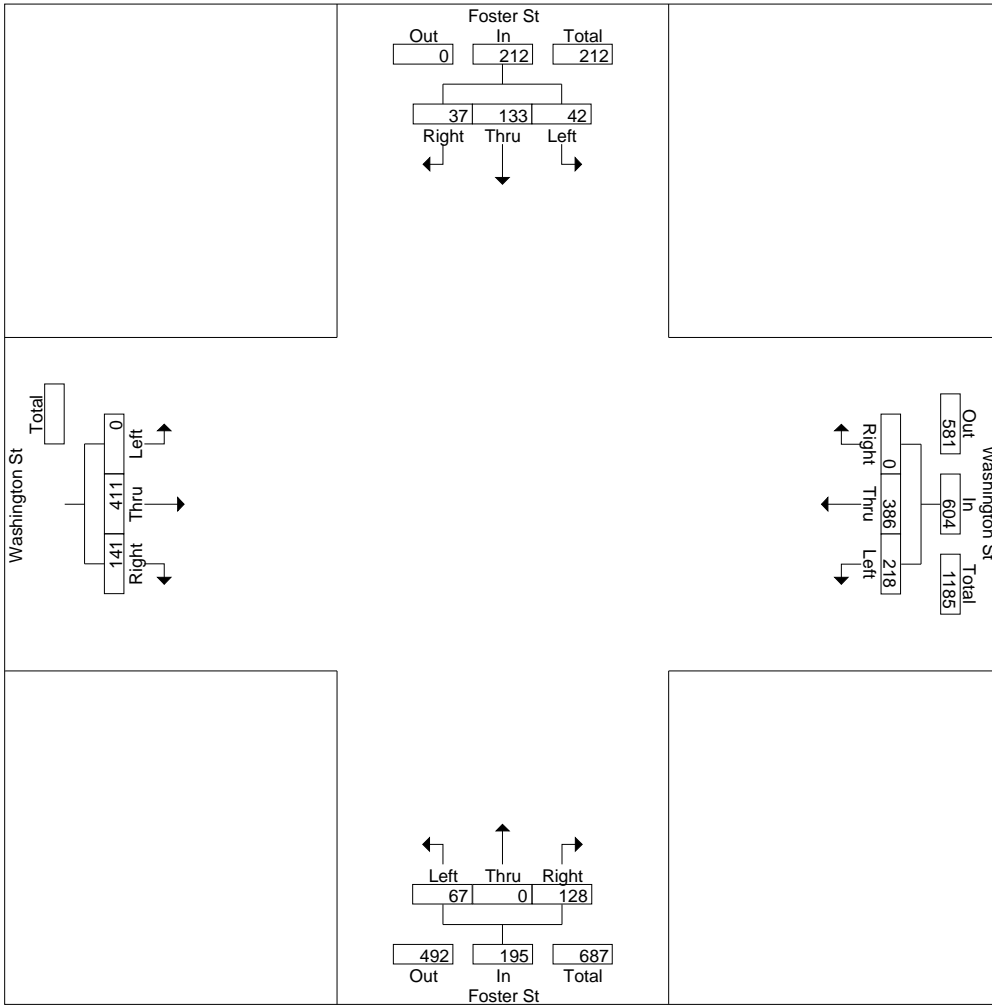

Accurate Counts
978-664-2565

File Name : 39000013
Site Code : 39000013
Start Date : 3/12/2008
Page No : 3

FosQ 0 w [] 0 d 0 0 0 R Gm 242.64 6997t m 2i..29 Ts (: 39000013)

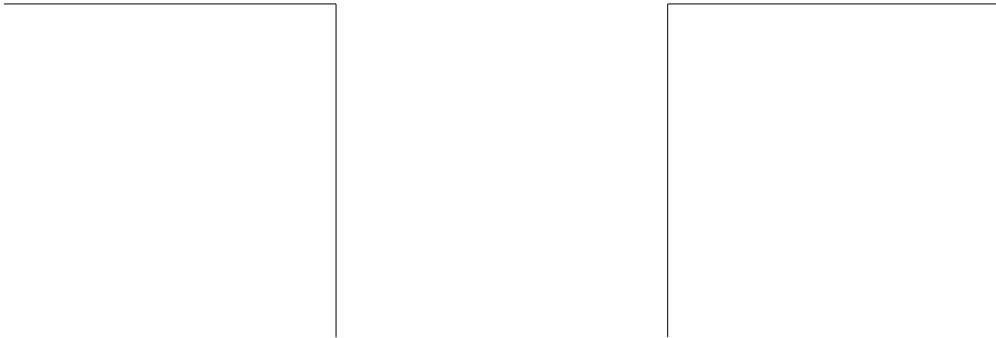
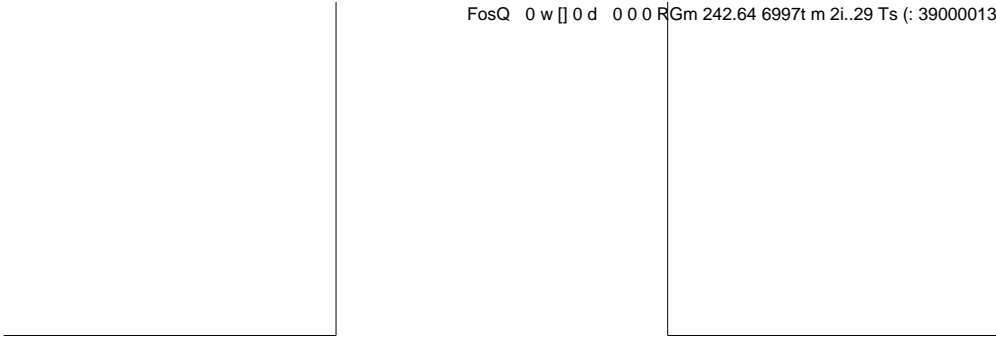

N/S Street : Foster Street
 E/W Street: Washington Street
 City/State : Brighton, MA
 Weather : Rain

Accurate Counts
 978-664-2565

File Name : 39000013
 Site Code : 39000013
 Start Date : 3/12/2008
 Page No : 1

Groups Printed- Trucks

Start Time	Foster St From North				Washington St From East				Foster St From South				Washington St From West			
	Left	Thru	Right	Peds	Left	Thru	Right	Peds	Left	Thru	Right	Peds	Left	Thru	Right	Peds

Accurate Counts
978-664-2565

Accurate Counts
978-664-2565

File Name : 39000013
Site Code : 39000013
Start Date : 3/12/2008
Page No : 3

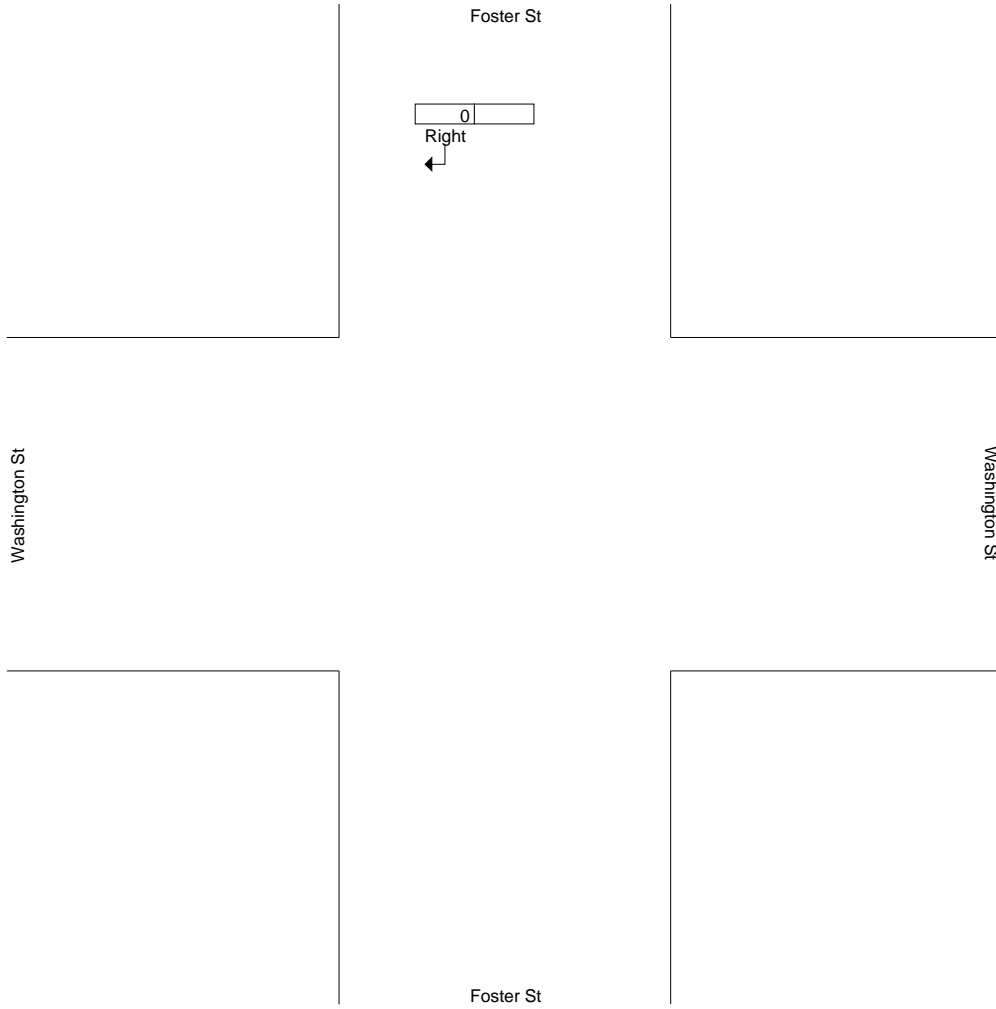

N/S Street : Market St / Chestnut Hill
E/W Street: Washington Street

Accurate Counts
978-664-2565

File Name : 39000014
Site Code : 39000014
Start Date : 3/12/2008
Page No : 1

Accurate Counts
978-664-2565

File Name : 39000014
Site Code : 39000014
Start Date : 3/12/2008
Page No : 2

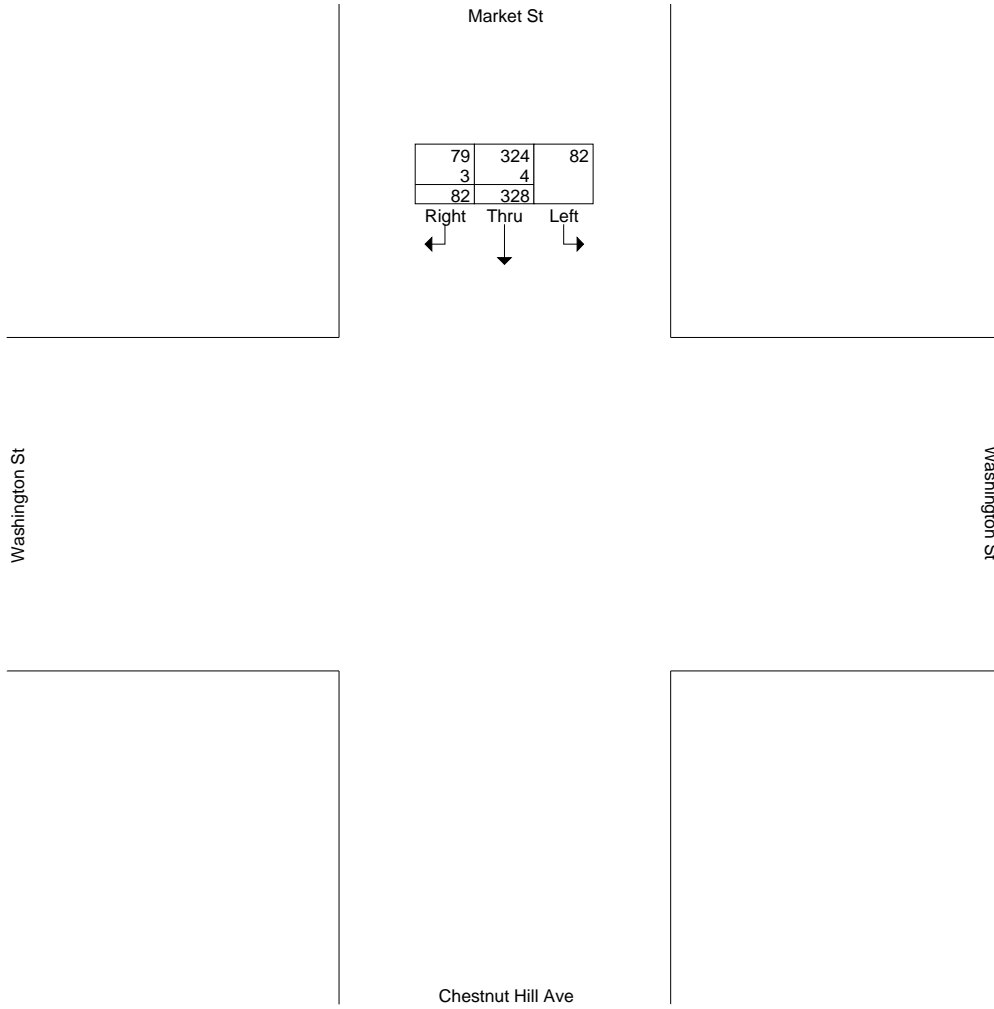

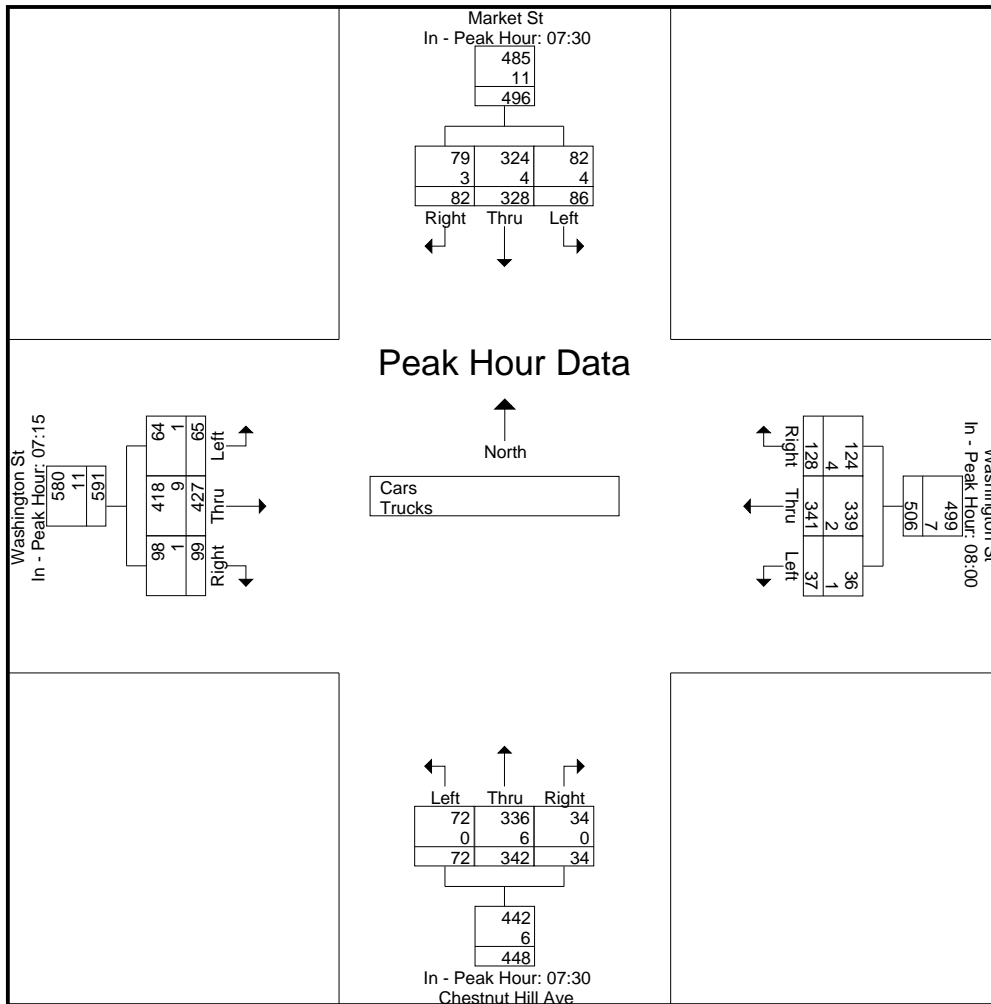

N/S Street : Market St / Chestnut Hill
 E/W Street: Washington Street
 City/State : Brighton, MA
 Weather : Rain

Accurate Counts
 978-664-2565

File Name : 39000014
 Site Code : 39000014
 Start Date : 3/12/2008
 Page No : 1

Groups Printed- Cars

Start Time	Market St From North				Washington St From East				Chestnut Hill Ave From South				Washington St From West				Exclu. Total	Inclu. Total	Int. Total
	Left	Thru	Right	Peds	Left	Thru	Right	Peds	Left	Thru	Right	Peds	Left	Thru	Right	Peds			
07:00	17	51	13	0	3	97	17	3	21	71	6	1	9	90	31	2	6	426	432
07:15	17	69	29	0	4	102	9	7	21	54	8	2	26	109					

Accurate Counts
978-664-2565

File Name : 39000014
Site Code : 39000014
Start Date : 3/12/2008
Page No : 2

Market St

Washington St

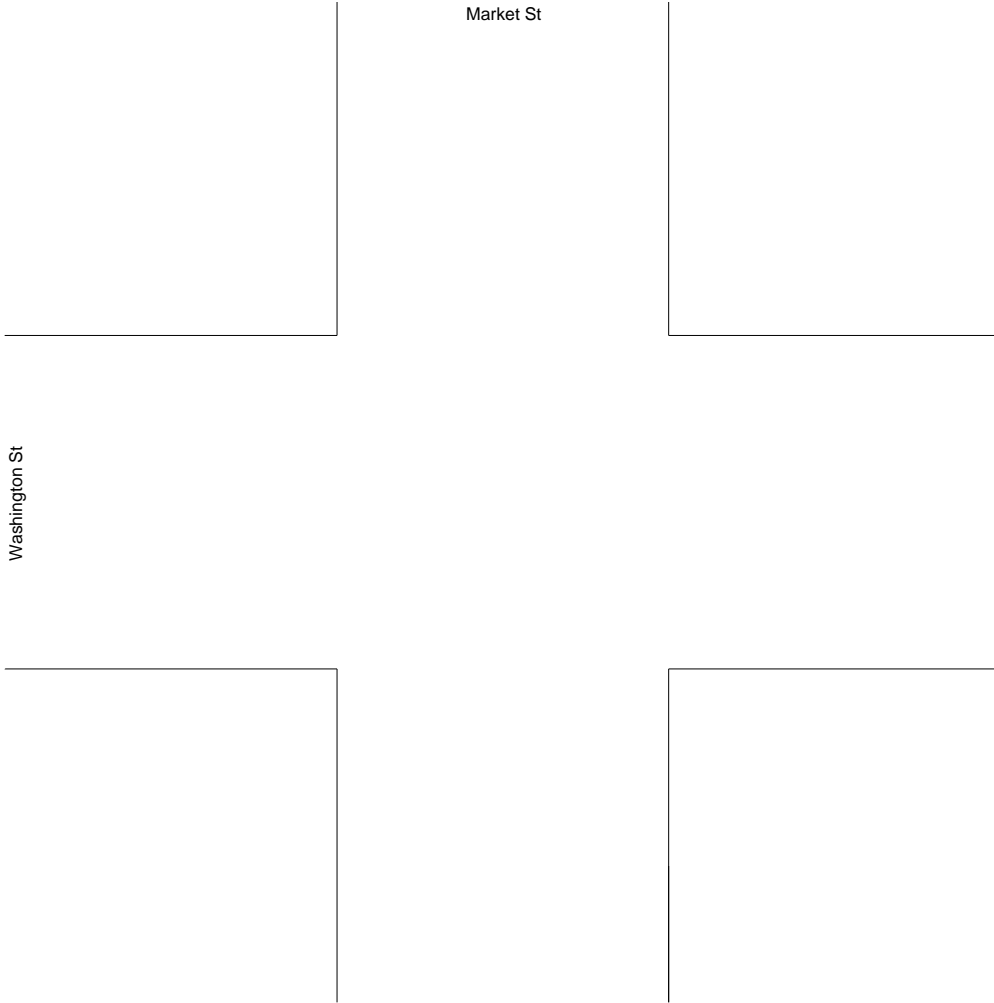

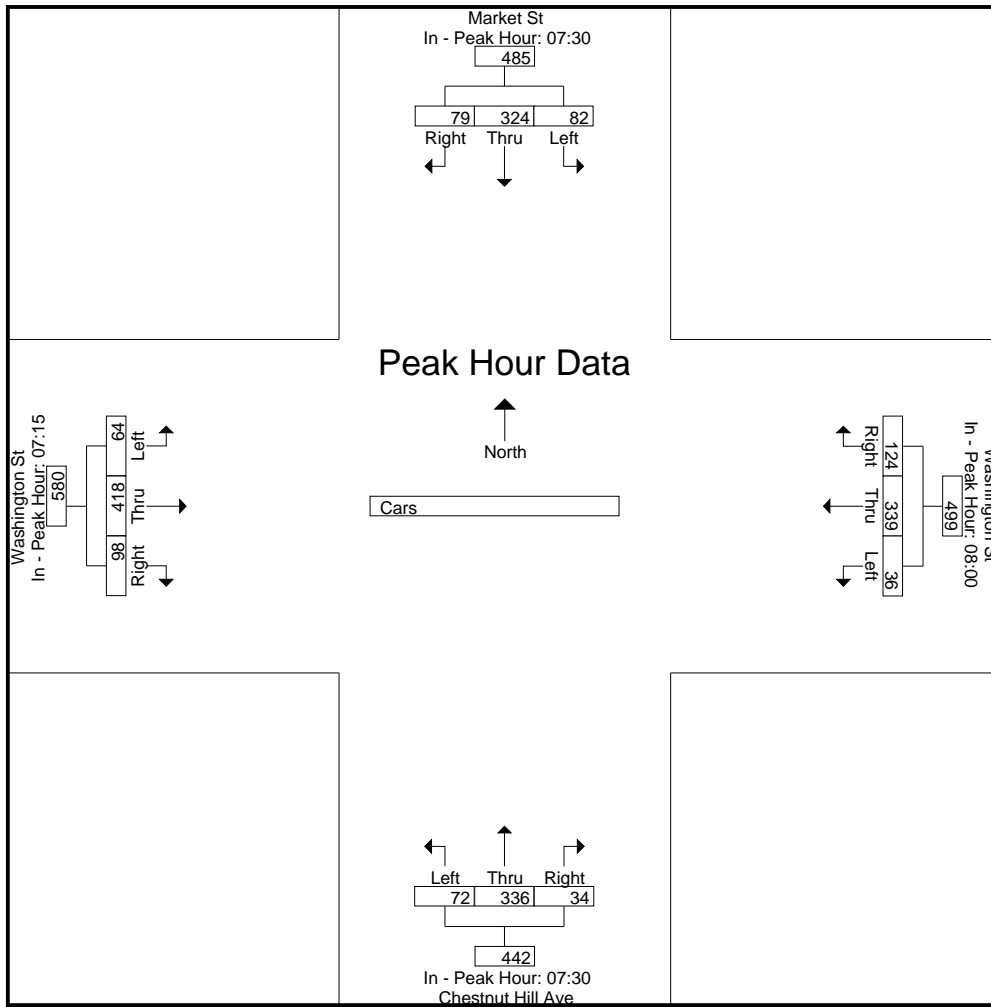

N/S Street : Market St / Chestnut Hill
E/W Street: Washington Street
City/State : Brighton, MA
Weather : Rain

Accurate Counts
978-664-2565

File Name : 39000014
Site Code : 39000014
Start Date : 3/12/2008
Page No : 1

Groups Printed- Trucks



Accurate Counts
978-664-2565

File Name : 39000014
Site Code : 39000014
Start Date : 3/12/2008
Page No : 2

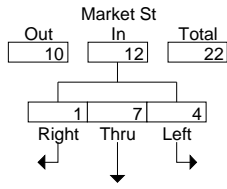

Washington St

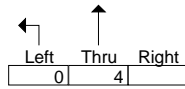
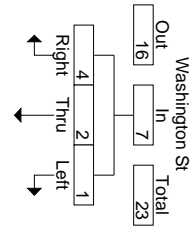

Chestnut Hill Ave

Accurate Counts
978-664-2565

File Name : 39000014
Site Code : 39000014
Start Date : 3/12/2008
Page No : 3

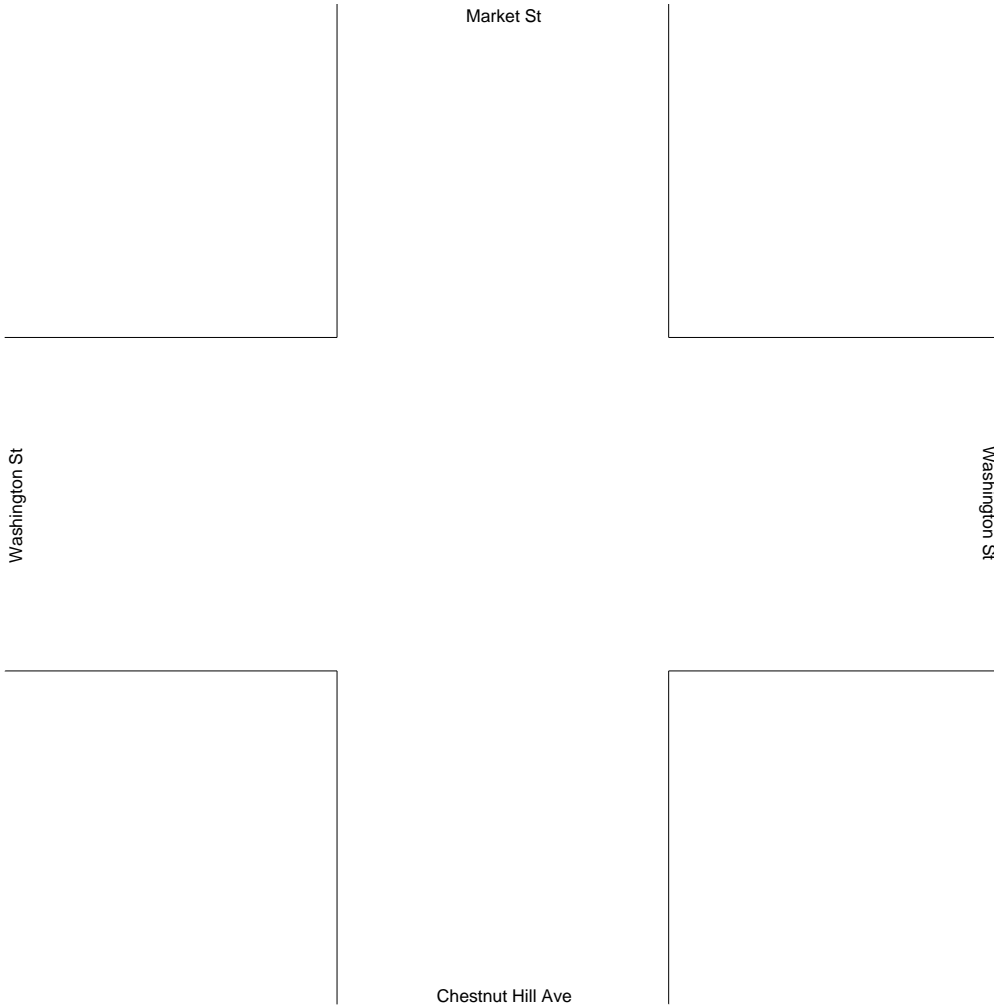

N/S Street : Market St / Chestnut Hill
E/W Street: Washington Street
City/State : Brighton, MA
Weather : Rain

Accurate Counts
978-664-2565

File Name : 39000014
Site Code : 39000014
Start Date : 3/12/2008
Page No : 1

Groups Printed- Cars - Trucks

	Market St From North	Washington St From East	Chestnut Hill Ave From South	Washington St From West
Start Time	Left			

Accurate Counts
978-664-2565

File Name : 39000014
Site Code : 39000014
Start Date : 3/12/2008
Page No : 2

Market St		
Out	In	Total
482	635	1117
5	1	6
487	636	1123

Right	Thru	Left
78	428	129
0	1	0
78	429	129

Washington St

Washington St		
Out	In	Total
492	573	1065
2	5	7
494	578	1072

Right	Thru	Left
133	418	22
1	4	0
134	422	22

Left	Thru	Right
86	269	20
1	4	
87	273	

Chestnut Hill Ave

N/S Street : Market St / Chestnut Hill
E/W Street: Washington Street
City/State : Brighton, MA
Weather : Rain

Accurate Counts
978-664-2565

File Name : 39000014
Site Code : 39000014
Start Date : 3/12/2008
Page No : 1

Groups Printed- Cars

	Market St From North	Washington St From East	Chestnut Hill Ave From South	Washington St From West
Start Time	Left			

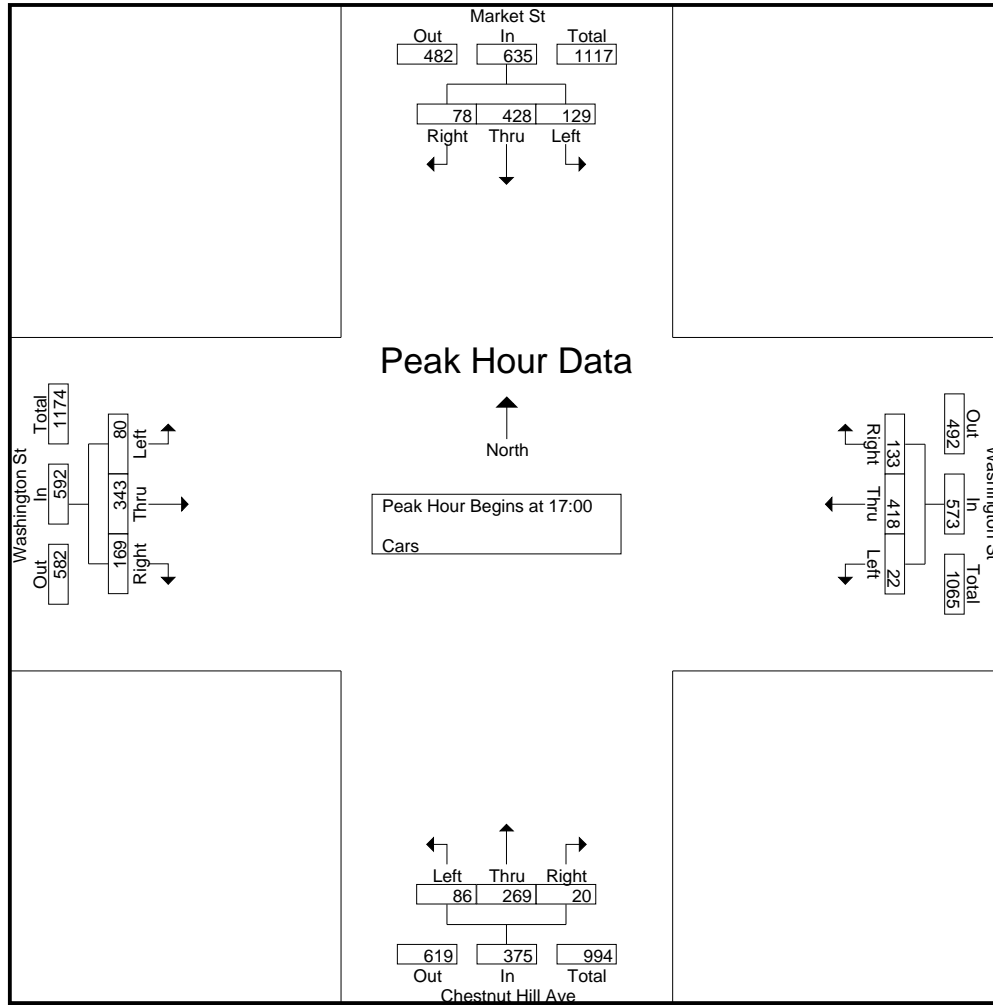

Peak Hour Analysis From 16:00 to 17:45 - Peak 1 of 1

Peak Hour for Each Approach Begins at:

	17:00				17:00				16:00				17:00			
+0 mins.	37	104	12	153	7	91	30	128	27	67	10	104	20	86	38	144
+15 mins.	28	104	11	143	4	115	25	144	20	77	5	102	17	94	38	149
+30 mins.	31	111	26	168	3	111	46	160	13	57	9	79	16	71	46	133
+45 mins.	33	109	29	171	8	101	32	141	19	72	8	99	27	92	47	166
Total Volume	129	428	78	635	22	418	133	573	79	273	32	384	80	343	169	592
% App. Total	20.3	67.4	12.3		3.8	72.9	23.2		20.6	71.1	8.3		13.5	57.9	28.5	
PHF	.872	.964	.672	.928	.688	.909	.723	.895	.731	.886	.800	.923	.741	.912	.899	.892

Accurate Counts
978-664-2565

File Name : 39000014
Site Code : 39000014
Start Date : 3/12/2008
Page No : 3

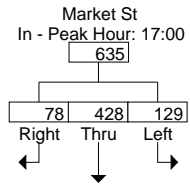

Washington St



Washington St

Chestnut Hill Ave

Accurate Counts
978-664-2565

Accurate Counts
978-664-2565

File Name : 39000014
Site Code : 39000014
Start Date : 3/12/2008
Page No : 3

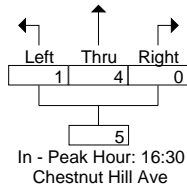
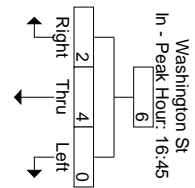
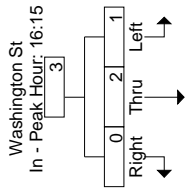
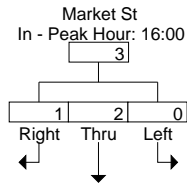

Accurate Counts
978-664-2565

Accurate Counts
978-664-2565

File Name : 39000016
Site Code : 39000016
Start Date : 3/25/2008
Page No : 2

Accurate Counts
978-664-2565

File Name : 39000016
Site Code : 39000016
Start Date : 3/25/2008
Page No : 3

St Thomas More Rd
In - Peak Hour: 08:00

203	
7	
210	
0	203
0	7
0	210
Right	Thru

Campanella Way

Left	Thru
0	
0	
0	

St Thomas More Rd

N/S Street : St. Thomas More Road
 E/W Street: Campanella Way
 City/State : Brighton, MA
 Weather : Clear

Accurate Counts
 978-664-2565

File Name : 39000016
 Site Code : 39000016
 Start Date : 3/25/2008
 Page No : 1

Groups Printed- Cars

Start Time	St Thomas More Rd From North			St Thomas More Rd From South			Campanella Way From West			Exclu. Total	Inclu. Total	Int. Total
	Thru	Right	Peds	Left	Thru	Peds	Left	Right	Peds			
07:00	29	0	0	0	44	1	10	12	4	5	95	100
07:15	21	0	0	0	67	0	21	24	1	1	133	134
07:30	26	0	0	0	50	0	13	22	5	5	111	116
07:45	37	0	0	0	80	2	18	13	4	6	148	154
Total	113	0	0	0	241	3	62	71	14	17	487	504
08:00	43	0	0	0	80	0	17	8	1	1	148	149
08:15	44	0	0	0	98	4	15	10	4	8	167	175
08:30	52	0	0	0	94	2	14	9	5	7	169	176
08:45	64	0	0	0	107	4	17	23	6	10	211	221
Total	203	0	0	0	379	10	63	50	16	26	695	721
Grand Total	316	0	0	0	620	13	125	121	30	43	1182	1225
Apprch %	100	0		0	100		50.8	49.2				
Total %	26.7	0		0	52.5		10.6	10.2		3.5	96.5	

Start Time	St Thomas More Rd From North			St Thomas More Rd From South			Campanella Way From West			Int. Total
	Thru	Right	App. Total	Left	Thru	App. Total	Left	Right	App. Total	
Peak Hour Analysis From 07:00 to 08:45 - Peak 1 of 1										
Peak Hour for Entire Intersection Begins at 08:00										
08:00	43	0	43	0	80	80	17	8	25	148
08:15	44	0	44	0	98	98	15	10	25	167
08:30	52	0	52	0	94	94	14	9	23	169
08:45	64	0	64	0	107	107	17	23	40	211
Total Volume	203	0	203	0	379	379	63	50	113	695
% App. Total	100	0		0	100		55.8	44.2		
PHF	.793	.000	.793	.000	.886	.886	.926	.543	.706	.823

Accurate Counts
978-664-2565

Accurate Counts
978-664-2565

File Name : 39000016
Site Code : 39000016
Start Date : 3/25/2008

Accurate Counts
978-664-2565

File Name : 39000016
Site Code : 39000016
Start Date : 3/25/2008
Page No : 1

Accurate Counts
978-664-2565

File Name : 39000016
Site Code : 39000016
Start Date : 3/25/2008
Page No : 2

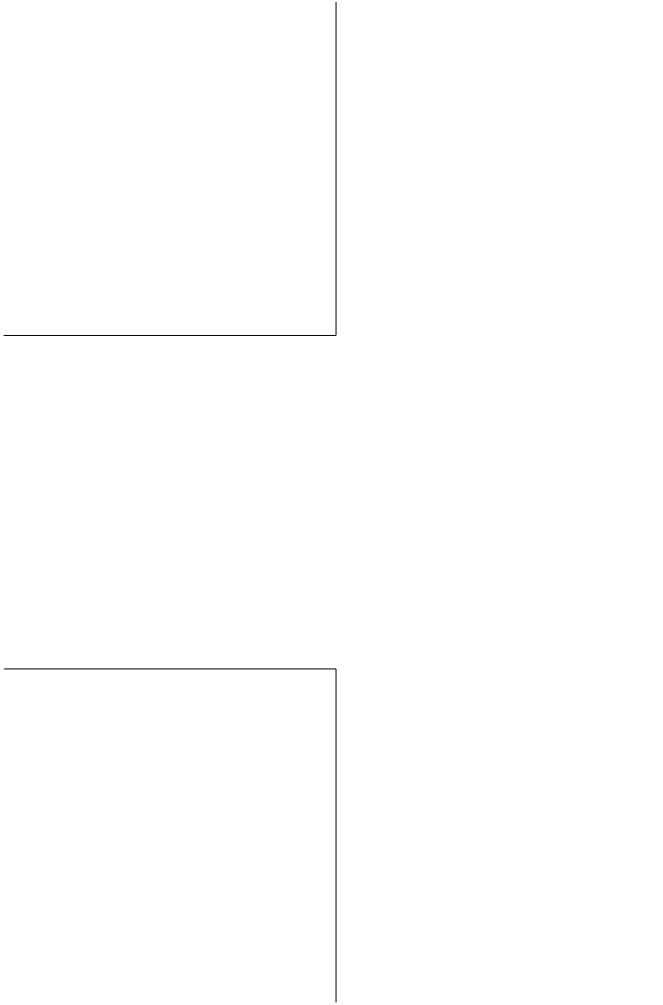

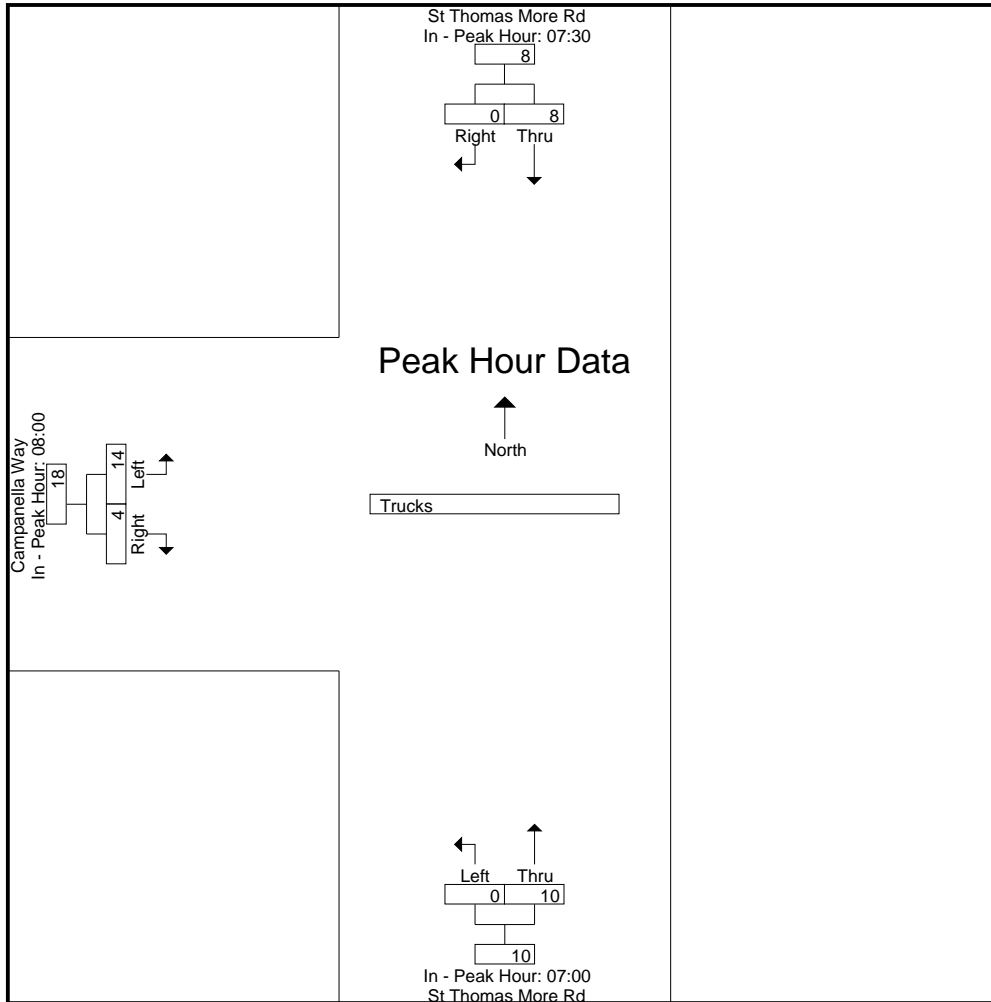

N/S Street : St. Thomas More Road
E/W Street: Campanella Way
City/State : Brighton, MA
Wea ET BT 517.56 -8.29 Ts (Page No) Tj ET BT 52on, MA

Accurate Counts
978-664-2565

File Name : 39000016
Site Code : 39000016
Start Date : 3/25/2008
Page No : 1

Accurate Counts
978-664-2565

File Name : 39000016
Site Code : 39000016
Start Date : 3/25/2008
Page No : 2



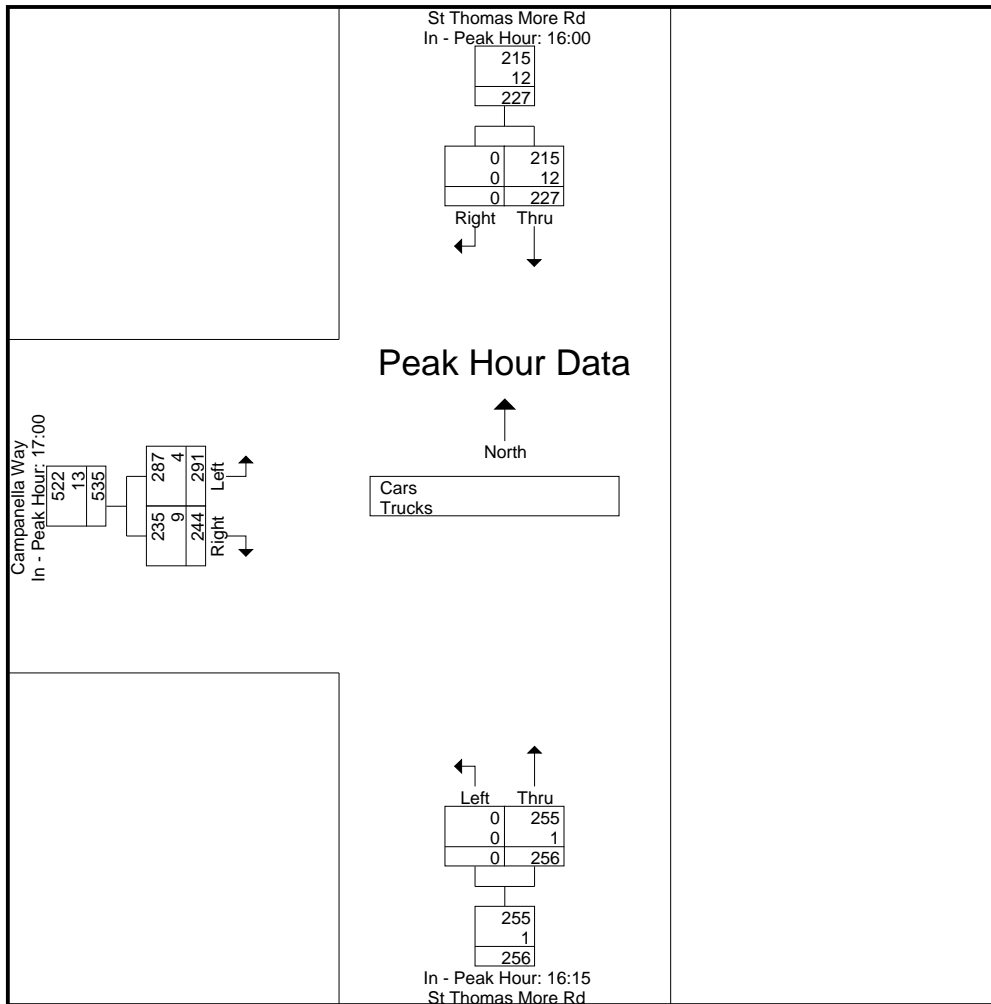

Accurate Counts
978-664-2565

File Name : 39000016
Site Code : 39000016
Start Date : 3/2/2011
Page No : 2

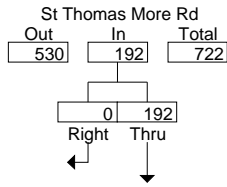

Peak Hour Data

Peak Hour Begins at 17:00
Cars

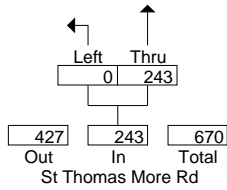
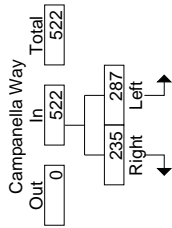

Accurate Counts
978-664-2565

File Name : 39000016
Site Code : 39000016
Start Date : 3/25/2008
Page No : 3

St Thomas More Rd
In - Peak Hour: 16:00

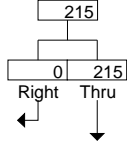

Campanella Way
In - Peak Hour: 17:00

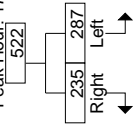

Cars

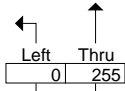

In - Peak Hour: 16:15
St Thomas More Rd

N/S Street : St. Thomas More Road
 E/W Street: Campanella Way
 City/State : Brighton, MA
 Weather : Clear

Accurate Counts
 978-664-2565

File Name : 39000016
 Site Code : 39000016
 Start Date : 3/25/2008
 Page No : 1

Groups Printed- Trucks

Start Time	St Thomas More Rd From North			St Thomas More Rd From South			Campanella Way From West			Exclu. Total	Inclu. Total	Int. Total
	Thru	Right	Peds	Left	Thru	Peds	Left	Right	Peds			
16:00	4	0	0	0	1	0	1	2	0	0	8	8
16:15	3	0	0	0	0	0	0	3	0	0	6	6
16:30	3	0	0	0	1	0	1	1	0	0	6	6
16:45	2	0	0	0	0	0	0	3	0	0	5	5
Total	12	0	0	0	2	0	2	9	0	0	25	25
17:00	3	0	0	0	0	0	1	3	0	0	7	7
17:15	1	0	0	0	0	0	0	1	0	0	2	2
17:30	2	0	0	0	2	0	3	2	0	0	9	9
17:45	1	0	0	0	1	0	0	3	0	0	5	5
Total	7	0	0	0	3	0	4	9	0	0	23	23
Grand Total	19	0	0	0	5	0	6	18	0	0	48	48
Apprch %	100	0		0	100		25	75				
Total %	39.6	0		0	10.4		12.5	37.5		0	100	

Start Time	St Thomas More Rd From North			St Thomas More Rd From South			Campanella Way From West			Int. Total
	Thru	Right	App. Total	Left	Thru	App. Total	Left	Right	App. Total	
16:00	4	0	4	0	1	1	1	2	3	8
16:15	3	0	3	0	0	0	0	3	3	6
16:30	3	0	3	0	1	1	1	1	2	6
16:45	2	0	2	0	0	0	0	3	3	5
Total Volume	12	0	12	0	2	2	2	9	11	25
% App. Total	100	0		0	100		18.2	81.8		
PHF	.750	.000	.750	.000	.500	.500	.500	.750	.917	.781

Peak Hour Analysis From 16:00 to 17:45 - Peak 1 of 1
 Peak Hour for Entire Intersection Begins at 16:00

Accurate Counts
978-664-2565

File Name : 39000016
Site Code : 39000016
Start Date : 3/25/2008
Page No : 2

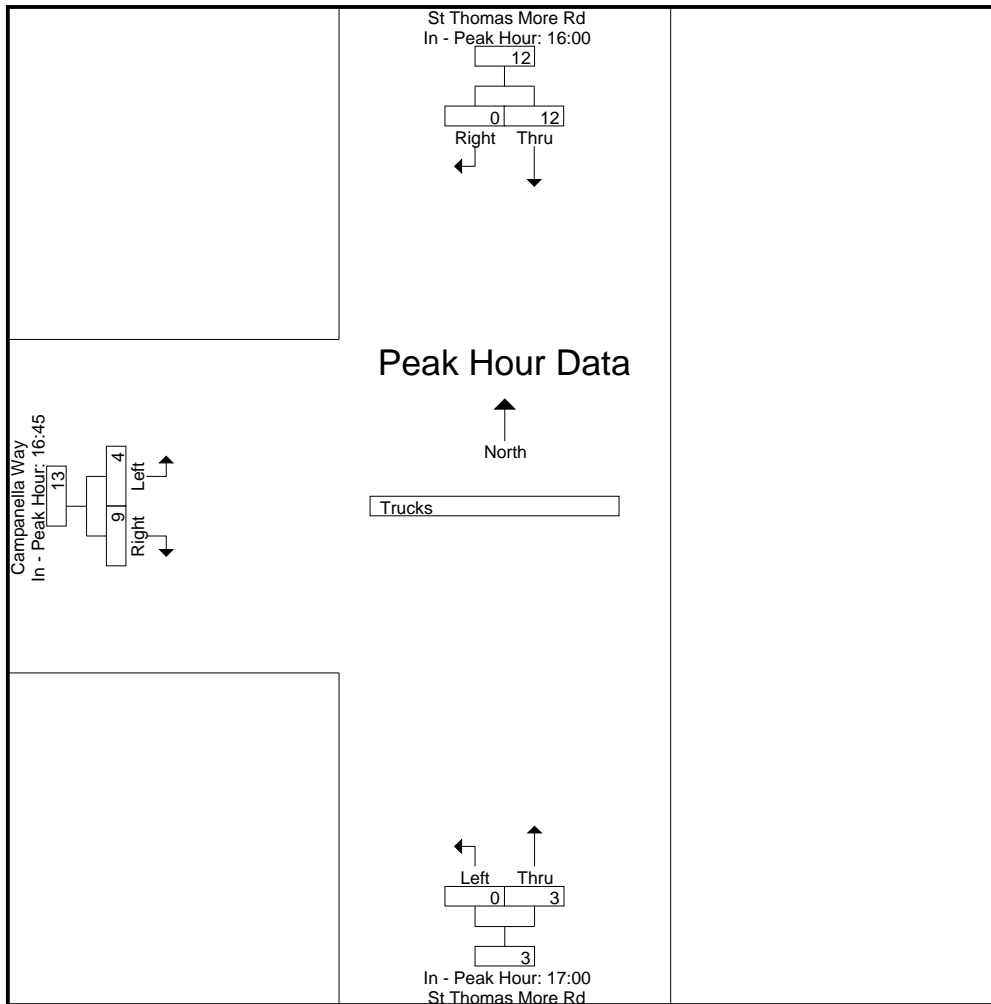

N/S Street : Foster Street
 E/W Street: Driveway
 City/State : Brighton, MA
 Weather : Clear

Accurate Counts
 978-664-2565

File Name : 39000017
 Site Code : 39000017
 Start Date : 3/25/2008
 Page No : 1

Groups Printed- Cars - Trucks

Start Time	Foster St From North			Foster St From South			Driveway From West			Exclu. Total	Inclu. Total	Int. Total
	Thru	Right	Peds	Left	Thru	Peds	Left	Right	Peds			
07:00	67	3	0	4	34	0	0	1	3	3	109	112
07:15	72	9	0	0	35	0	0	2	4	4	118	122
07:30	106	4	0	1	33	0	0	1	1	1	145	146
07:45	109	9	0	0	47	0	1	3	0	0	169	169
Total	354	25	0	5	149	0	1	7	8	8	541	549
08:00	109	5	0	4	32	0	0	3	0	0	153	153
08:15	106	4	0	2	39	0	1	1	0	0	153	153
08:30	118	8	0	3	29	0	1	0	0	0	159	159
08:45	125	15	0	2	38	0	1	1	0	0	182	182
Total	458	32	0	11	138	0	3	5	0	0	647	647
Grand Total	812	57	0	16	287	0	4	12	8	8	1188	1196
Apprch %	93.4	6.6		5.3	94.7		25	75				
Total %	68.4	4.8		1.3	24.2		0.3	1		0.7	99.3	
Cars	802	57		15	284		3	12		0	0	1181
% Cars	98.8	100	0	93.8	99	0	75	100	100	0	0	98.7
Trucks	10	0		1	3		1	0		0	0	15
% Trucks	1.2	0	0	6.2	1	0	25	0	0	0	0	1.3

Start Time	Foster St From North			Foster St From South			Driveway From West			Int. Total
	Thru	Right	App. Total	Left	Thru	App. Total	Left	Right	App. Total	

Accurate Counts
978-664-2565

File Name : 39000017
Site Code : 39000017
Start Date

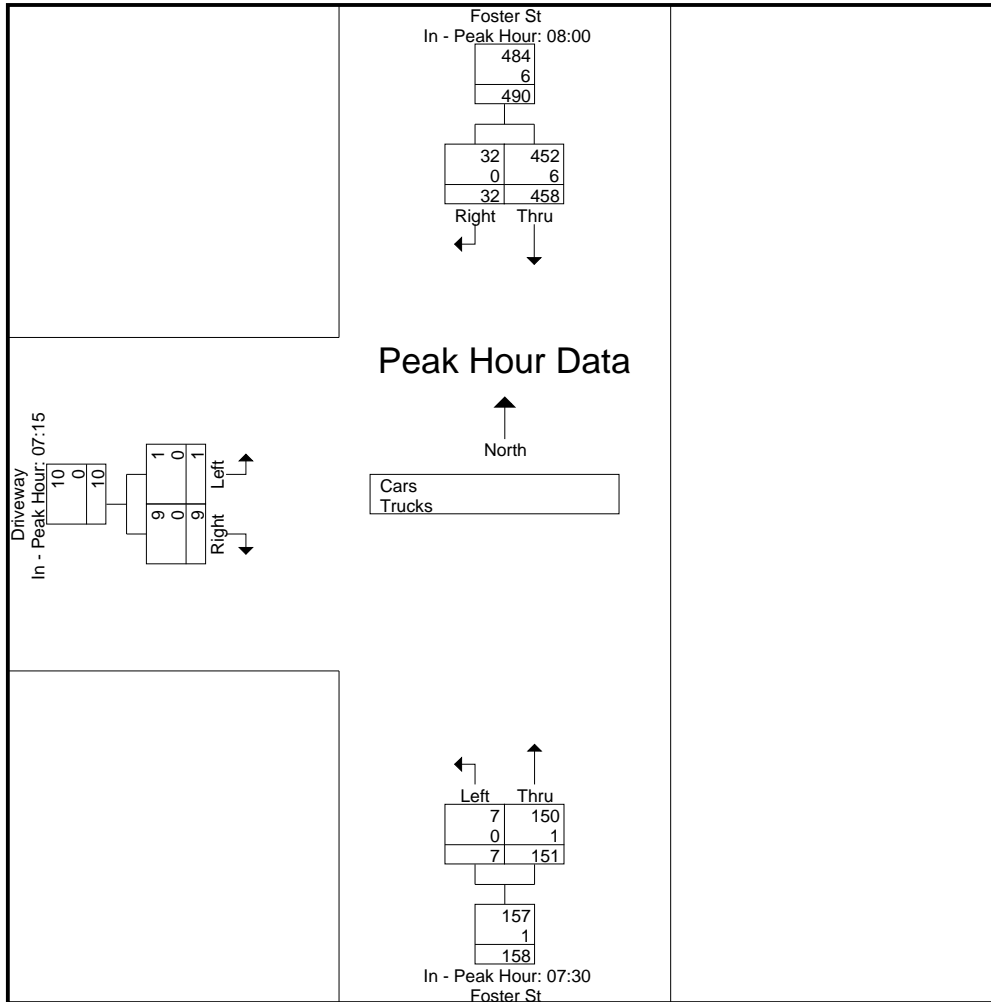

N/S Street : Foster Street
 E/W Street: Driveway
 City/State : Brighton, MA
 Weather : Clear

Accurate Counts
 978-664-2565

File Name : 39000017
 Site Code : 39000017
 Start Date : 3/25/2008
 Page No : 1

Groups Printed- Cars

Start Time	Foster St From North			Foster St From South			Driveway From West			Exclu. Total	Inclu. Total	Int. Total
	Thru	Right	Peds	Left	Thru	Peds	Left	Right	Peds			
07:00	66	3	0	4	34	0	0	1	3	3	108	111
07:15	72	9	0	0	35	0	0	2	4	4	118	122
07:30	104	4	0	1	33	0	0	1	1	1	143	144
07:45	108	9	0	0	47	0	1	3	0	0	168	168
Total	350	25	0	5	149	0	1	7	8	8	537	545
08:00	108	5	0	4	32	0	0	3	0	0	152	152
08:15	105	4	0	2	38	0	1	1	0	0	151	151
08:30	118	8	0	3	29	0	1	0	0	0	159	159
08:45	121	15	0	1	36							

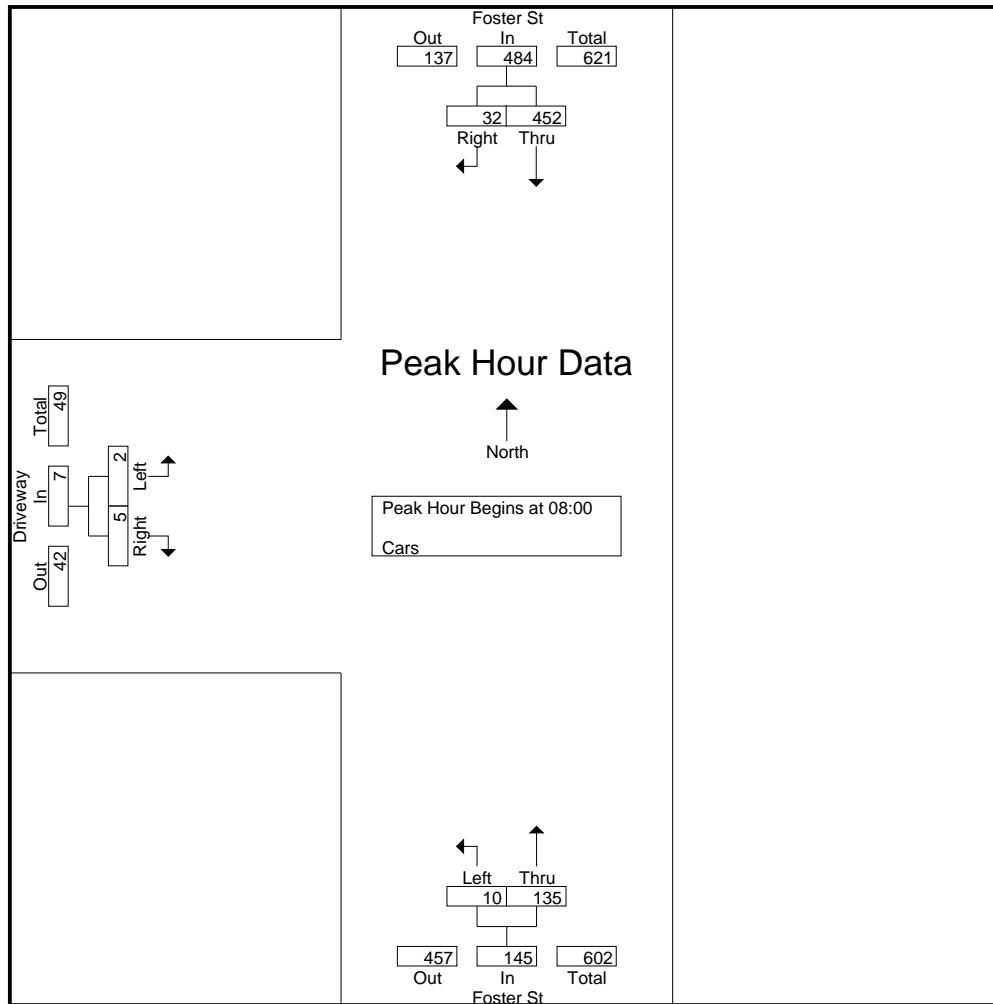

Peak Hour Analysis From 07:00 to 08:45 - Peak 1 of 1

Peak Hour for Each Approach Begins at:

	08:00			07:30			07:15		
+0 mins.	108	5	113	1	33	34	0	2	2
+15 mins.	105	4	109	0	47	47	0	1	1
+30 mins.	118	8	126	4	32	36	1	3	4

Accurate Counts
978-664-2565

File Name : 39000017

N/S Street : Foster Street
 E/W Street: Driveway
 City/State : Brighton, MA
 Weather : Clear

Accurate Counts
 978-664-2565

File Name : 39000017
 Site Code : 39000017
 Start Date : 3/25/2008
 Page No : 1

Groups Printed- Trucks

Start Time	Foster St From North			Foster St From South			Driveway From West			Exclu. Total	Inclu. Total	Int. Total
	Thru	Right	Peds	Left	Thru	Peds	Left	Right	Peds			
07:00	1	0	0	0	0	0	0	0	0	0	1	1
07:15	0	0	0	0	0	0	0	0	0	0	0	0
07:30	2	0	0	0	0	0	0	0	0	0	2	2
07:45	1	0	0	0	0	0	0	0	0	0	1	1
Total	4	0	0	0	0	0	0	0	0	0	4	4
08:00	1	0	0	0	0	0	0	0	0	0	1	1
08:15	1	0	0	0	1	0	0	0	0	0	2	2
08:30	0	0	0	0	0	0	0	0	0	0	0	0
08:45	4	0	0	1	2	0	1	0	0	0	8	8
Total	6	0	0	1	3	0	1	0	0	0	11	11
Grand Total	10	0	0	1	3	0	1	0	0	0	15	15
Apprch %	100	0		25	75		100	0				
Total %	66.7	0		6.7	20		6.7	0		0	100	

Start Time	Foster St From North			Foster St From South			Driveway From West			Int. Total
	Thru	Right	App. Total	Left	Thru	App. Total	Left	Right	App. Total	
08:00	1	0	1	0	0	0	0	0	0	1
08:15	1	0	1	0	1	1	0	0	0	2
08:30	0	0	0	0	0	0	0	0	0	0
08:45	4	0	4	1	2	3	1	0	1	8
Total Volume	6	0	6	1	3	4	1	0	1	11
% App. Total	100	0		25	75		100	0		
PHF	.375	.000	.375	.250	.375	.333	.250	.000	.250	.344

Peak Hour Analysis From 07:00 to 08:45 - Peak 1 of 1
 Peak Hour for Entire Intersection Begins at 08:00

Accurate Counts
978-664-2565

File Name : 39000017
Site Code : 39000017
Start Date : 3/25/2008
Page No : 2

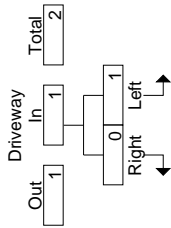
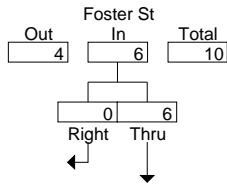

Peak Hour Begins at 08:00
Trucks

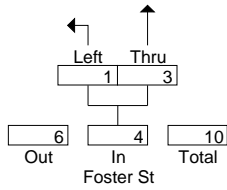

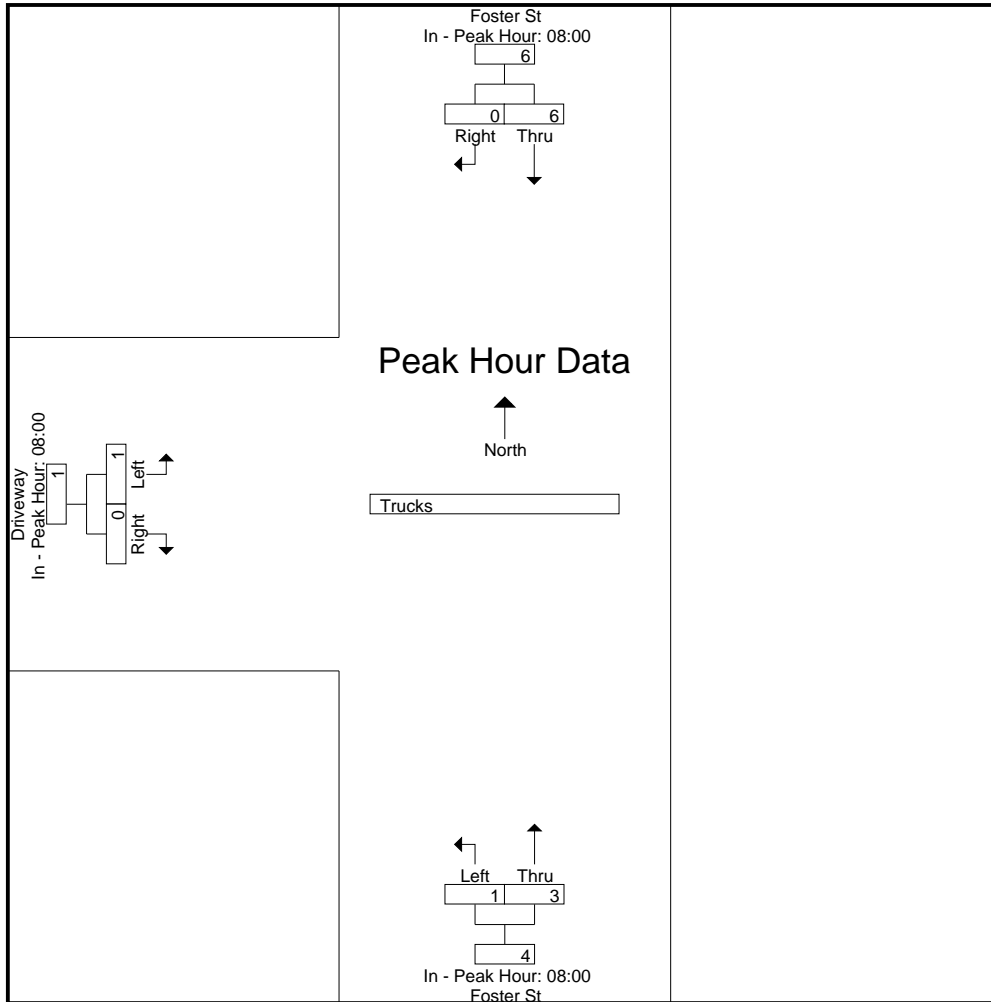

N/S Street : Foster Street
 E/W Street: Driveway
 City/State : Brighton, MA
 Weather : Clear

Accurate Counts
 978-664-2565

File Name : 39000017
 Site Code : 39000017
 Start Date : 3/25/2008
 Page No : 1

Groups Printed- Cars - Trucks

Start Time	Foster St From North			Foster St From South			Driveway From West			Exclu. Total	Inclu. Total	Int. Total
	Thru	Right	Peds	Left	Thru	Peds	Left	Right	Peds			
16:00	107	0	0	2	28	0	3	1	0	0	141	141
16:15	114	5	0	2	21	2	1	2	2	4	145	149
16:30	118	4	0	1	32	0	4	1	1	1	160	161
16:45	84	4	1	0	17	0	2	4	3	4	111	115
Total	423	13	1	5	98	2	10	8	6	9	557	566
17:00	108	2	0	2	29	1	6	2	6	7	149	156
17:15	127	1	0	1	38	0	4	2	3	3	173	176
17:30	117	2	0	1	24	0	1	1	1	1	146	147
17:45	136	4	1	0	22	0	3	5	2	3	170	173
Total	488	9	1	4	113	1	14	10	12	14	638	652
Grand Total	911	22	2	9	211	3	24	18	18	23	1195	1218
Apprch %	97.6	2.4		4.1	95.9		57.1	42.9				
Total %	76.2	1.8		0.8	17.7		2	1.5		1.9	98.1	
Cars	903	22		8	207		24	18		0	0	1205
% Cars	99.1	100	100	88.9	98.1	100	100	100	100	0	0	98.9
Trucks	8	0		1	4		0	0		0	0	13
% Trucks	0.9	0	0	11.1	1.9	0	0	0	0	0	0	1.1

Start Time	Foster St From North			Foster St From South			Driveway From West			Int. Total
	Thru	Right	App. Total	Left	Thru	App. Total	Left	Right	App. Total	
Peak Hour Analysis From 16:00 to 17:45 - Peak 1 of 1										
Peak Hour for Entire Intersection Begins at 17:00										
17:00	108	2	110	2	29	31	6	2	8	149
17:15	127	1	128	1	38	39	4	2	6	173
17:30	117	2	119	1	24	25	1	1	2	146
17:45	136	4	140	0	22	22	3	5	8	170
Total Volume	488	9	497	4	113	117	14	10	24	638
% App. Total	98.2	1.8		3.4	96.6		58.3	41.7		
PHF	.897	.563	.888	.500	.743	.750	.583	.500	.750	.922
Cars	485	9	494	3	112	115	14	10	24	633
% Cars	99.4	100	99.4	75.0	99.1	98.3	100	100	100	99.2
Trucks	3	0	3	1	1	2	0	0	0	5
% Trucks	0.6	0	0.6	25.0	0.9	1.7	0	0	0	0.8

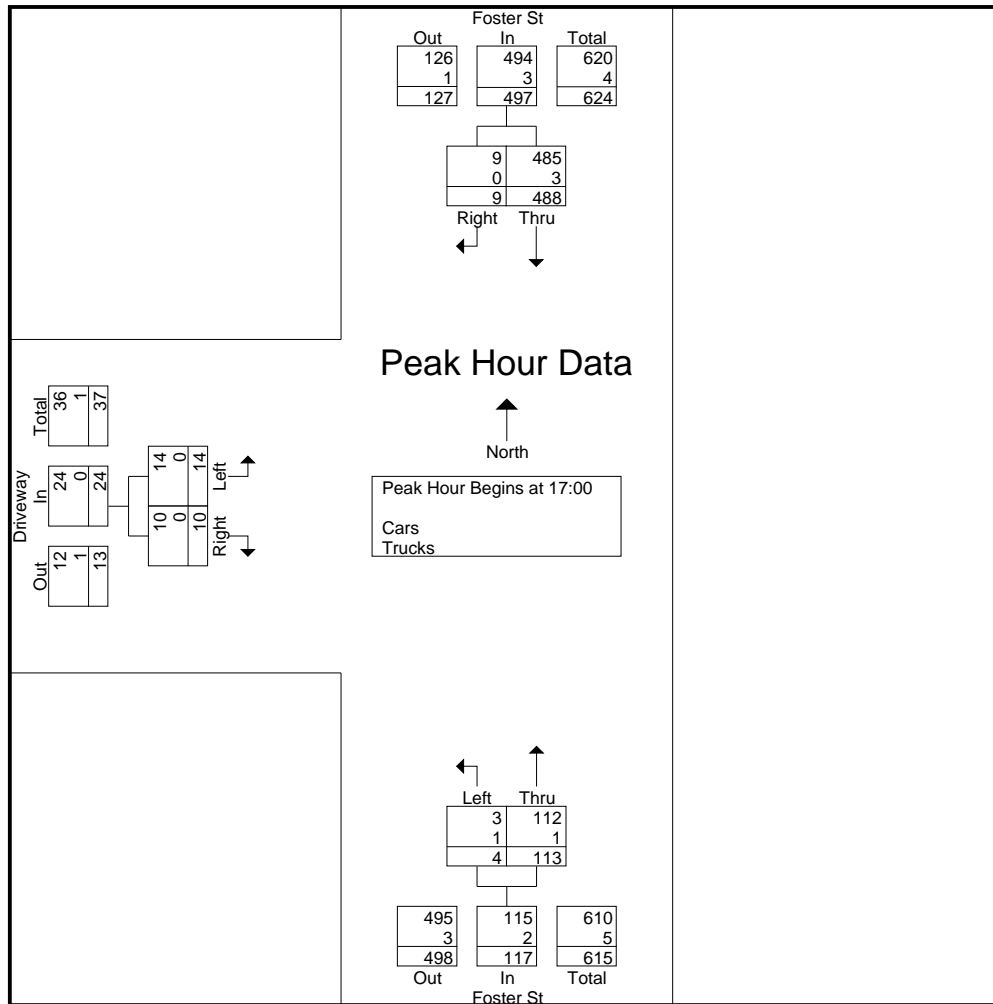

Peak Hour Analysis From 16:00 to 17:45 - Peak 1 of 1

Peak Hour for Each Approach Begins at:

	17:00			16:30			16:30		
+0 mins.	108	2	110	1	32	33	4	1	5
+15 mins.	127	1	128	0	17	17	2	4	6
+30 mins.	117	2	119	2	29	31	6	2	8
+45 mins.	136	4	140	1	38	39	4	2	6
Total Volume	488	9	497	4	116	120	16	9	25
% App. Total	98.2	1.8		3.3	96.7		64	36	
PHF	.897	.563	.888	.500	.763	.769	.667	.563	.781
Cars	485	9	494	3	114	117	16	9	25
% Cars	99.4	100	99.4	75	98.3	97.5	100	100	100
Trucks	3	0	3	1	2	3	0	0	0
% Trucks	0.6	0	0.6	25	1.7	2.5	0	0	0

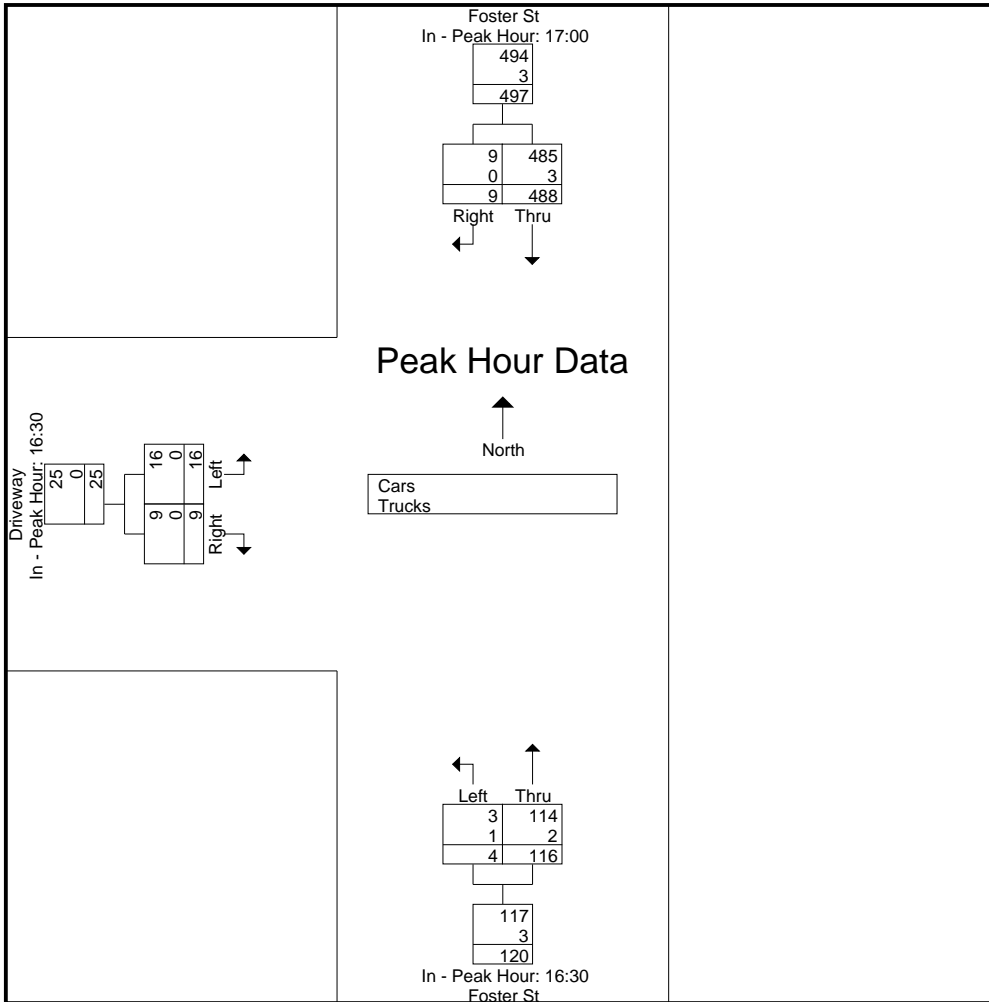

N/S Street : Foster Street
 E/W Street: Driveway
 City/State : Brighton, MA
 Weather : Clear

Accurate Counts
 978-664-2565

File Name : 39000017
 Site Code : 39000017
 Start Date : 3/25/2008
 Page No : 1

Groups Printed- Cars

Start Time	Foster St From North			Foster St From South			Driveway From West			Exclu. Total	Inclu. Total	Int. Total
	Thru	Right	Peds	Left	Thru	Peds	Left	Right	Peds			
16:00	105	0	0	2	28	0	3	1	0	0	139	139
16:15	111	5	0	2	20	2	1	2	2	4	141	145
16:30	118	4	0	1	31	0	4	1	1	1	159	160
16:45	84	4	1	0	16	0	2	4	3	4	110	114
Total	418	13	1	5	95	2	10	8	6	9	549	558
17:00	106	2	0	1	29	1	6	2	6	7	146	153
17:15	127	1	0	1	38	0	4	2	3	3	173	176
17:30	117	2	0	1	24	0	1	1	1	1	146	147
17:45	135	4	1	0	21	0	3	5	2	3	168	171
Total	485	9	1	3	112	1	14	10	12	14	633	647
Grand Total	903	22	2	8	207	3	24	18	18	23	1182	1205
Apprch %	97.6	2.4		3.7	96.3		57.1	42.9				
Total %	76.4	1.9		0.7	17.5		2	1.5	112			

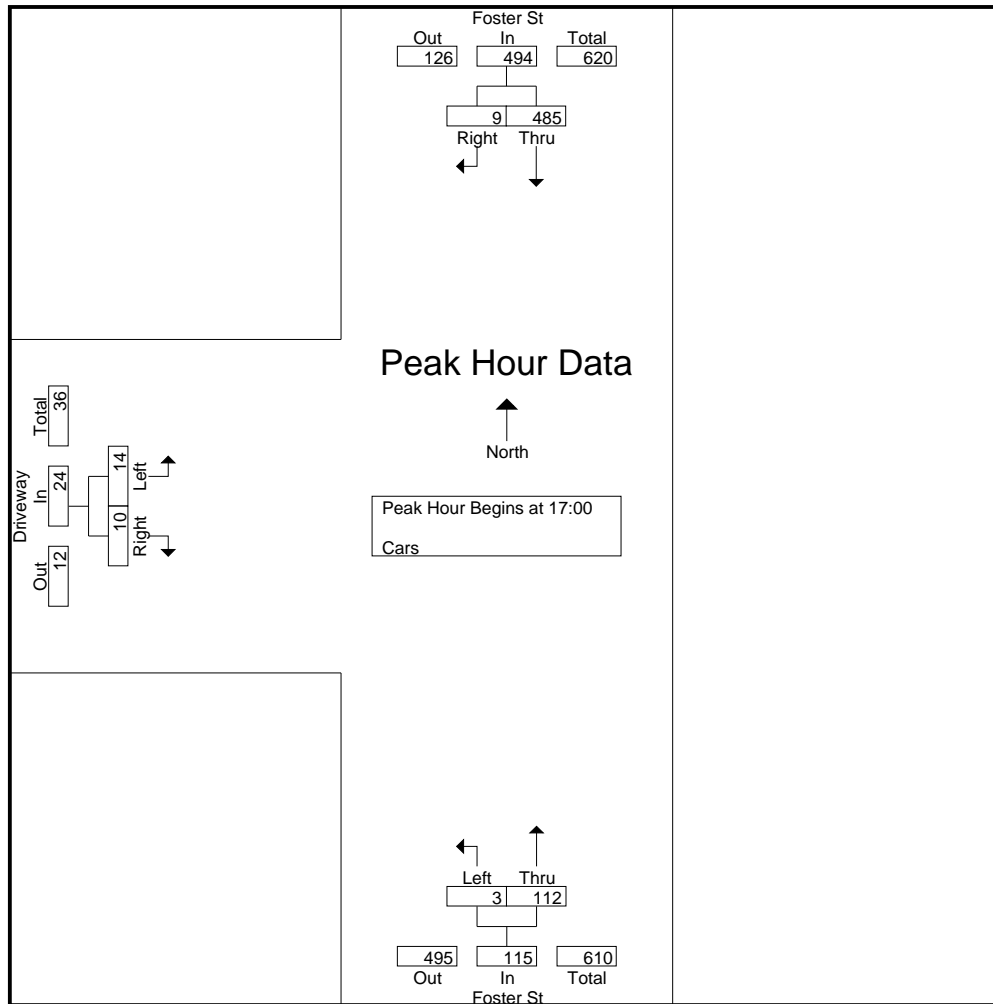

Peak Hour Analysis From 16:00 to 17:45 - Peak 1 of 1

Peak Hour for Each Approach Begins at:

	17:00			16:30			16:30		
+0 mins.	106	2	108	1	31	32	4	1	5
+15 mins.	127	1	128	0	16	16	2	4	6
+30 mins.	117	2	119	1	29	30	6	2	8
+45 mins.	135	4	139	1	38	39	4	2	6
Total Volume	485	9	494	3	114	117	16	9	25
% App. Total	98.2	1.8		2.6	97.4		64	36	
PHF	.898	.563	.888	.750	.750	.750	.667	.563	.781

Accurate Counts
978-664-2565

File Name : 39000017
Site Code : 39000017
Start Date : 3/25/2008
Page No : 3

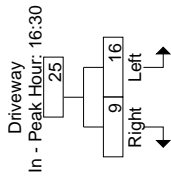
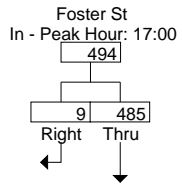

Cars

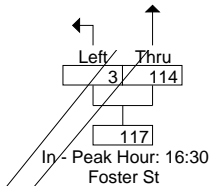

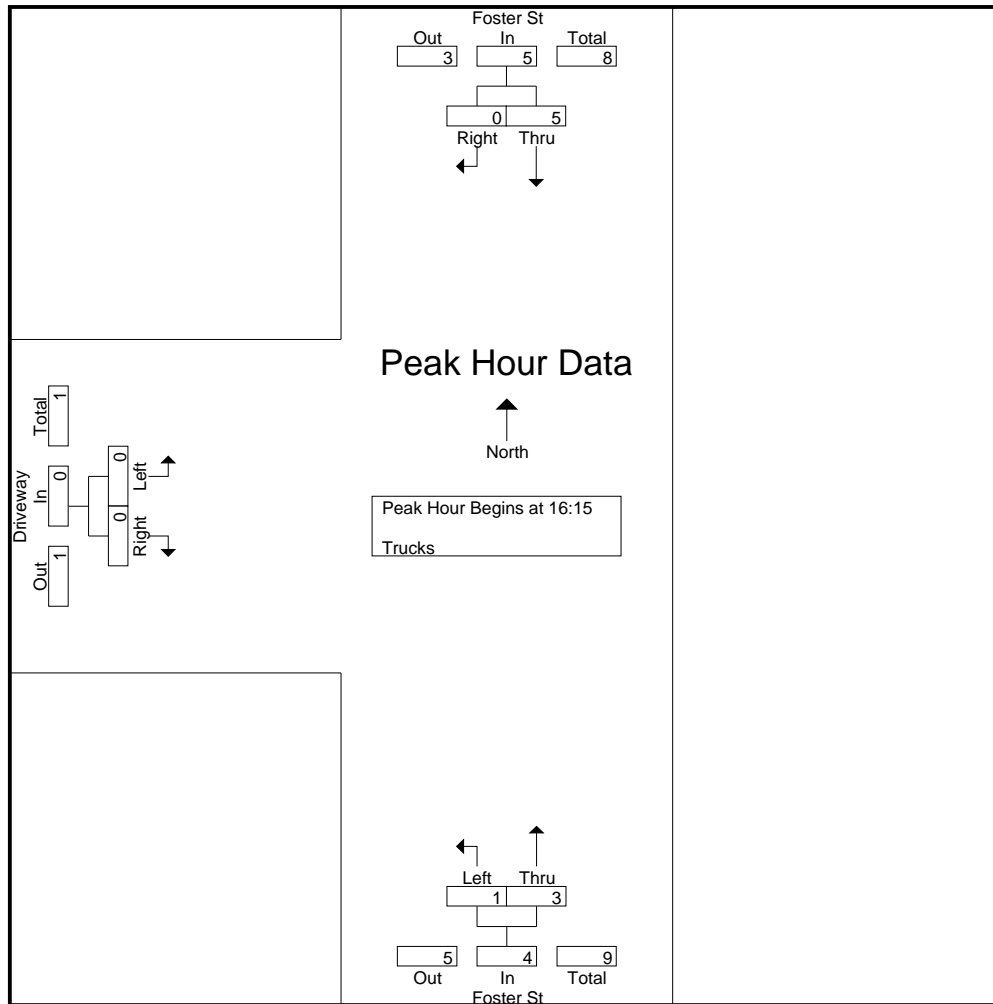

Peak Hour Analysis From 16:00 to 17:45 - Peak 1 of 1

Peak Hour for Each Approach Begins at:

	16:00			16:15			16:00		
+0 mins.	2	0	2	0	1	1	0	0	0
+15 mins.	3	0	3	0	1	1	0	0	0
+30 mins.	0	0	0	0	1	1	0	0	0
+45 mins.	0	0	0	1	0	1	0	0	0
Total Volume	5	0	5	1	3	4	0	0	0
% App. Total	100	0		25	75		0	0	
PHF	.417	.000	.417	.250	.750	1.000	.000	.000	.000

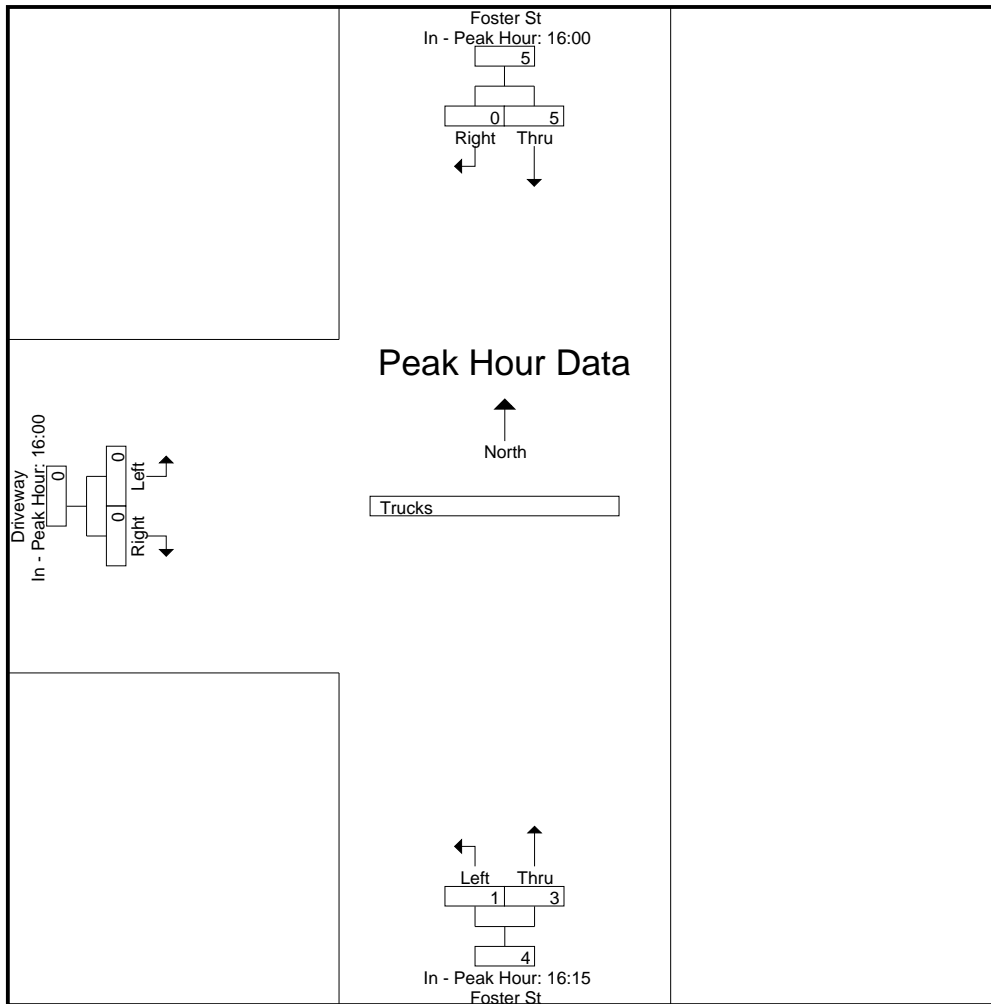

N/S Street : BC Driveway
E/W Street: Commonwealth Avenue
City/State : Brighton, MA
Weather : Clear

Accurate Counts
978-664-2565

File Name : 39000018
Site Code : 39000018
Start Date : 3/25/2008
Page No : 1

Groups Printed- Cars - Trucks

Start Time	BC Drive From North			Commonwealth Ave From East			Commonwealth Ave From West		
	Left	Right	Peds	Thru	Right	Peds	Left	Thru	Peds

Accurate Counts
978-664-2565

File Name : 39000018
Site Code : 39000018
Start Date : 3/25/2008
Page No : 3

N/S Street : BC Driveway
E/W Street: Commonwealth Avenue
City/State : Brighton, MA
Weather : Clear

Accurate Counts
978-664-2565

File Name : 39000018
Site Code : 39000018
Start Date : 3/25/2008
Page No : 1

Groups Printed- Cars

Accurate Counts
978-664-2565

File Name : 39000018
Site Code : 39000018
Start Date : 3/25/2008
Page No : 2

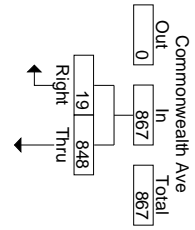
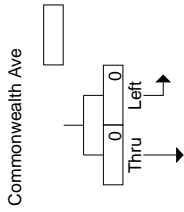
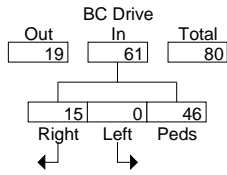

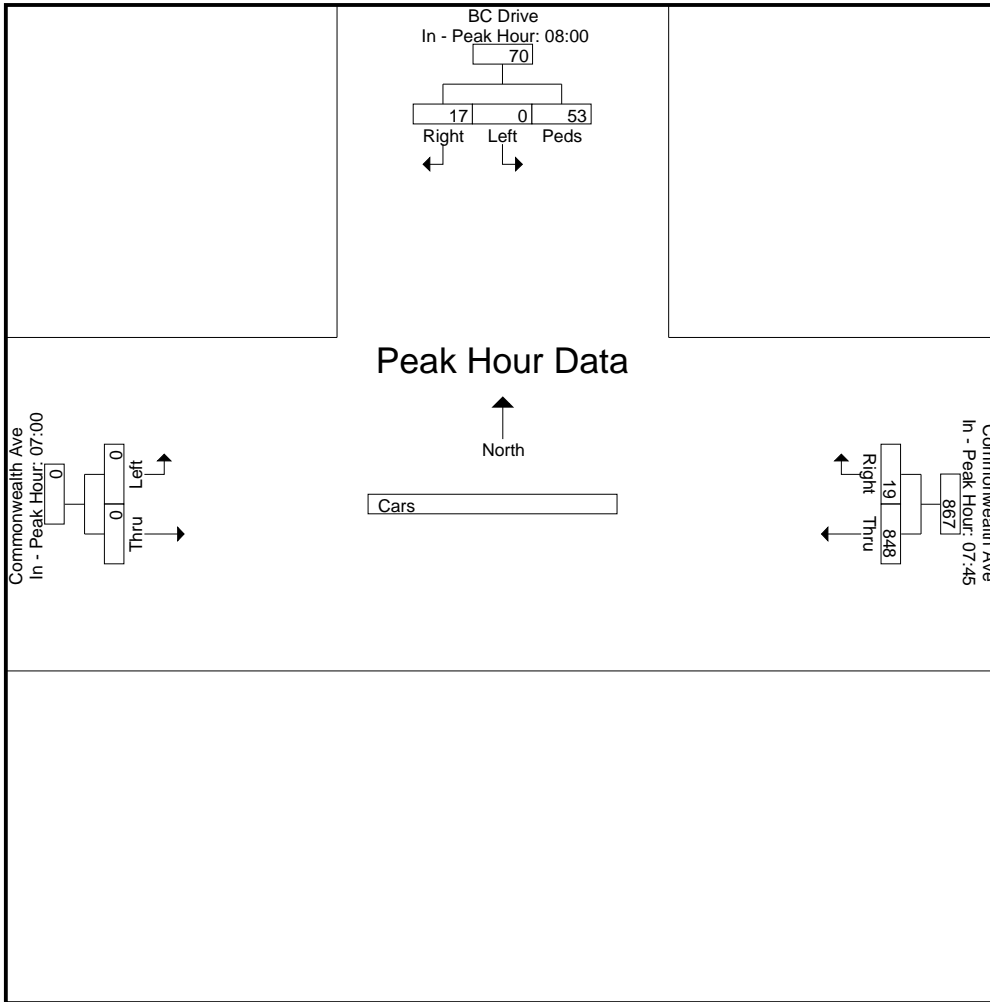

Accurate Counts
978-664-2565

File Name : 39000018
Site Code : 39000018
Start Date : 3/25/2008

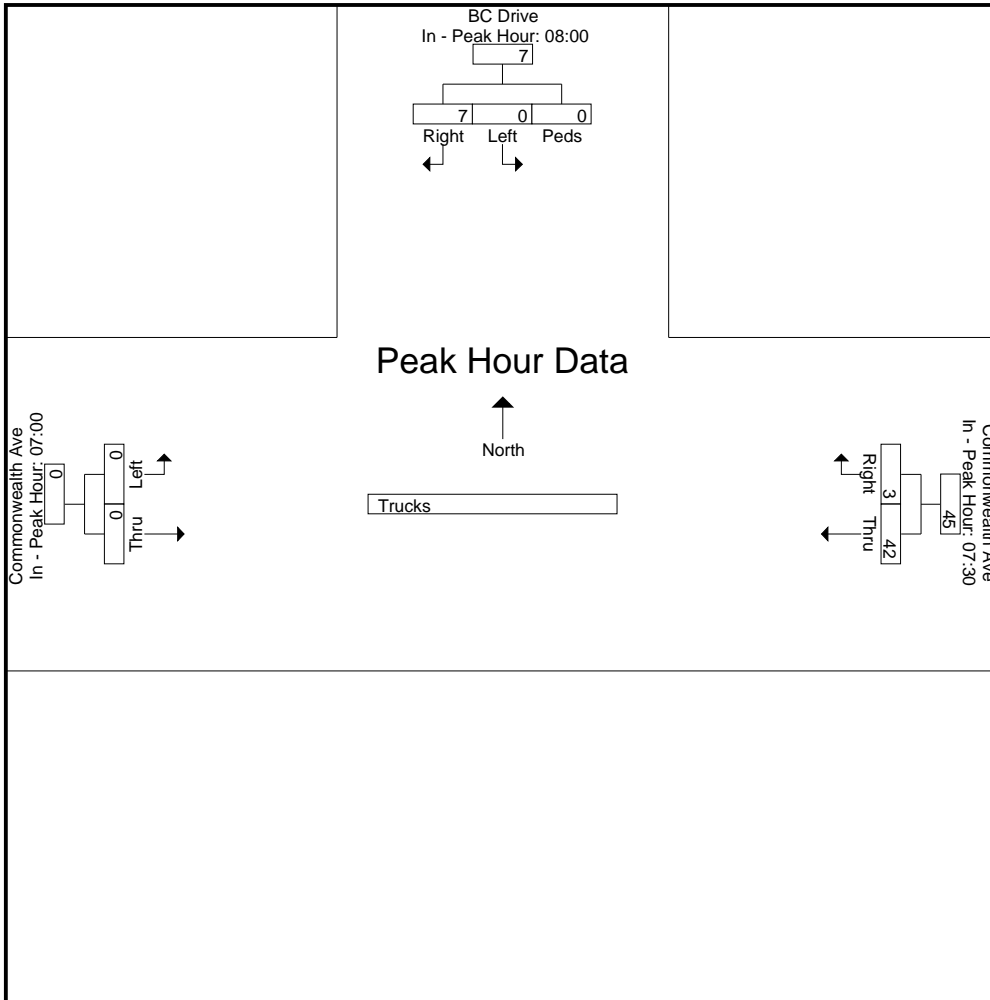

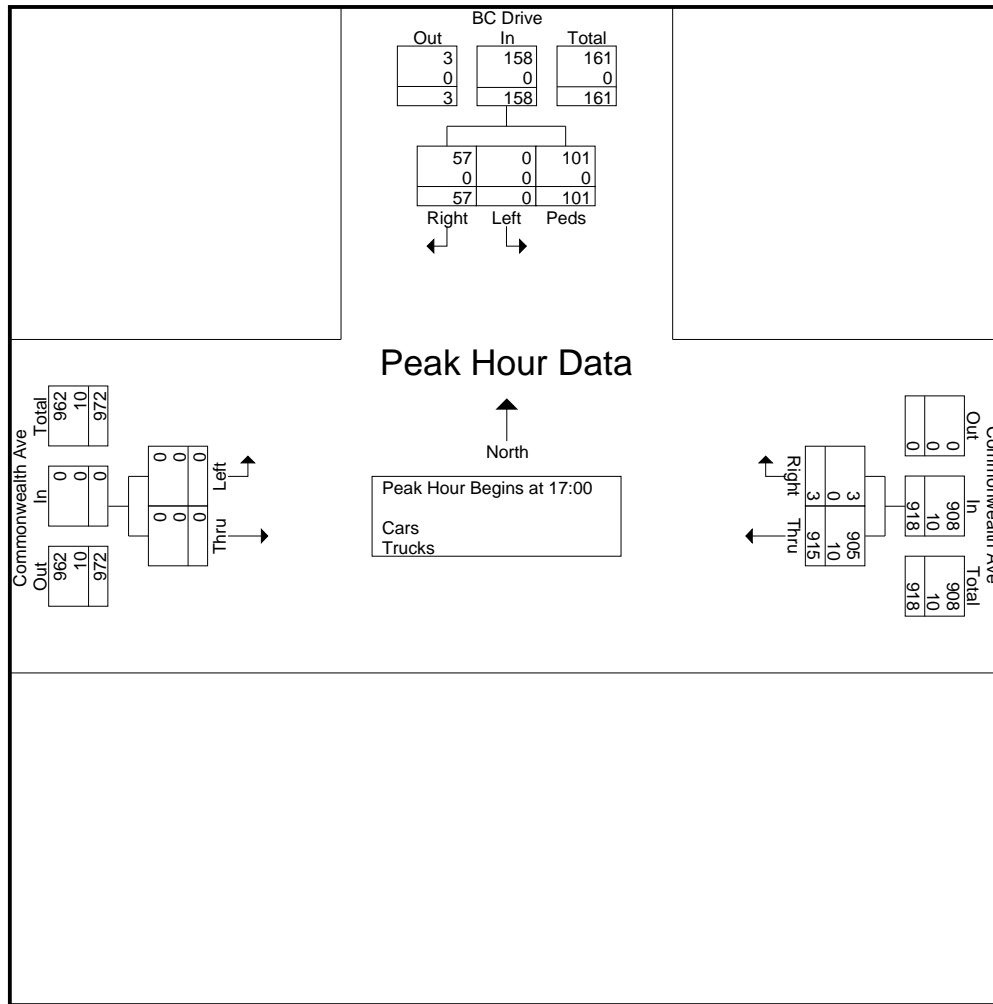

Peak Hour Analysis From 16:00 to 17:45 - Peak 1 of 1

Peak Hour for Each Approach Begins at:

	17:00				17:00			16:00		
+0 mins.	0	15	20	35	207	1	208	0	0	0
+15 mins.	0	11	33	44	227	0	227	0	0	0
+30 mins.	0	16	32	48	235	1	236	0	0	0
+45 mins.	0	15	16	31	246	1	247	0	0	0
Total Volume	0	57	101	158	915	3	918	0	0	0

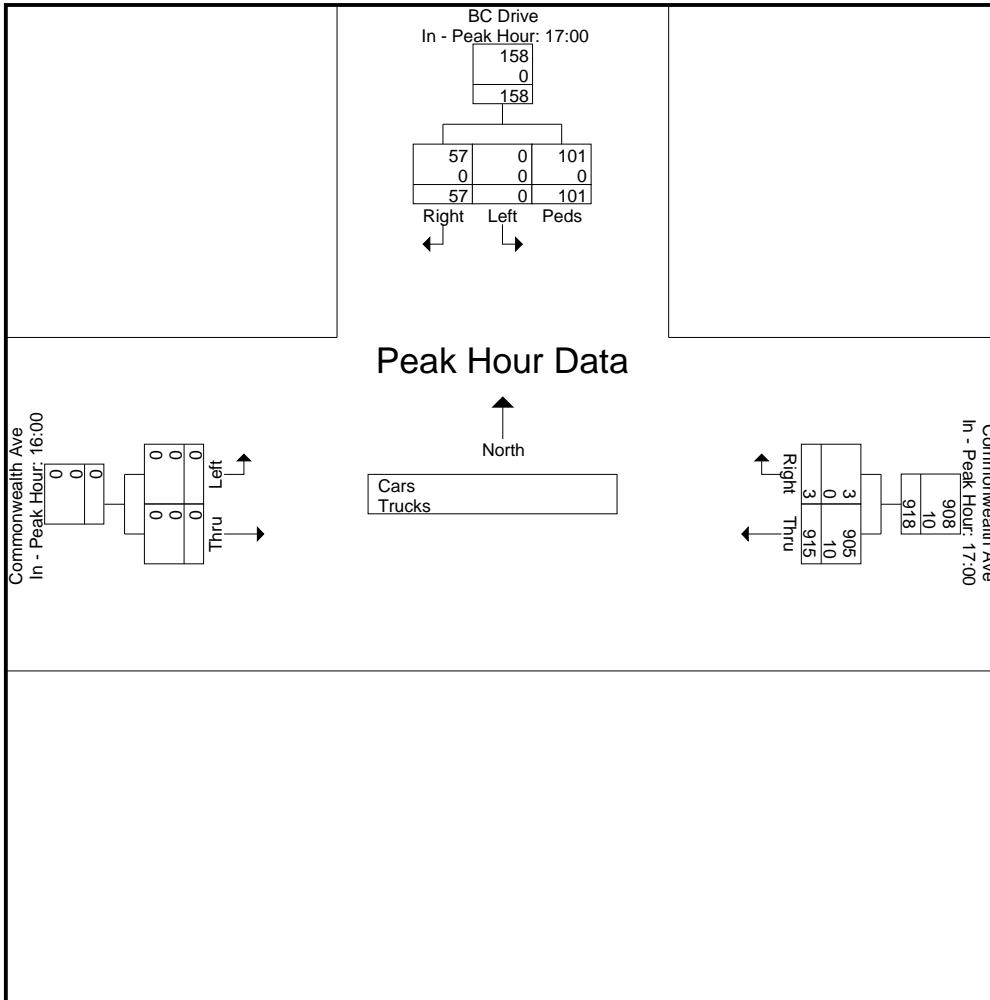

N/S Street : BC Driveway
E/W Street: Commonwealth Avenue
City/State : Brighton, MA
Weather : Clear

Accurate Counts
978-664-2565

File Name : 39000018
Site Code : 39000018
Start Date : 3/25/2008
Page No : 1

Groups Printed- Cars

	BC Drive From North	Commonwealth Ave From East	Commonwealth Ave
--	------------------------	-------------------------------	------------------

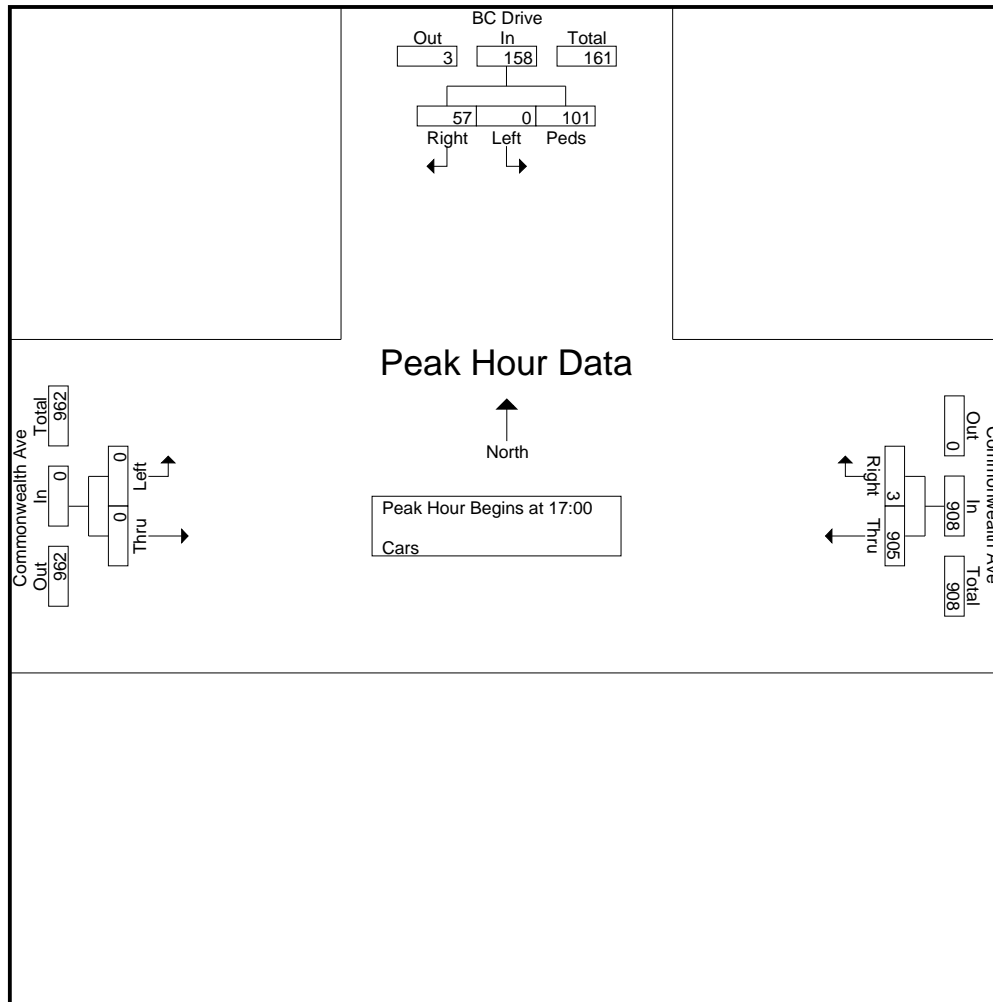

Peak Hour Analysis From 16:00 to 17:45 - Peak 1 of 1

Peak Hour for Each Approach Begins at:

	17:00				17:00			16:00		
+0 mins.	0	15	20	35	204	1	205	0	0	0
+15 mins.	0	11	33	44	225	0	225	0	0	0
+30 mins.	0	16	32	48	232	1	233	0	0	0
+45 mins.	0	15	16	31	244	1	245	0	0	0
Total Volume	0	57	101	158	905	3	908	0	0	0
% App. Total	0	36.1	63.9		99.7	0.3		0	0	
PHF	.000	.891	.765	.823	.927	.750	.927	.000	.000	.000

Accurate Counts
978-664-2565

File Name : 39000018
Site Code : 39000018
Start Date : 3/25/2008

Accurate Counts
978-664-2565

File Name : 39000018
Site Code : 39000018
Start Date : 3/25/2008
Page No

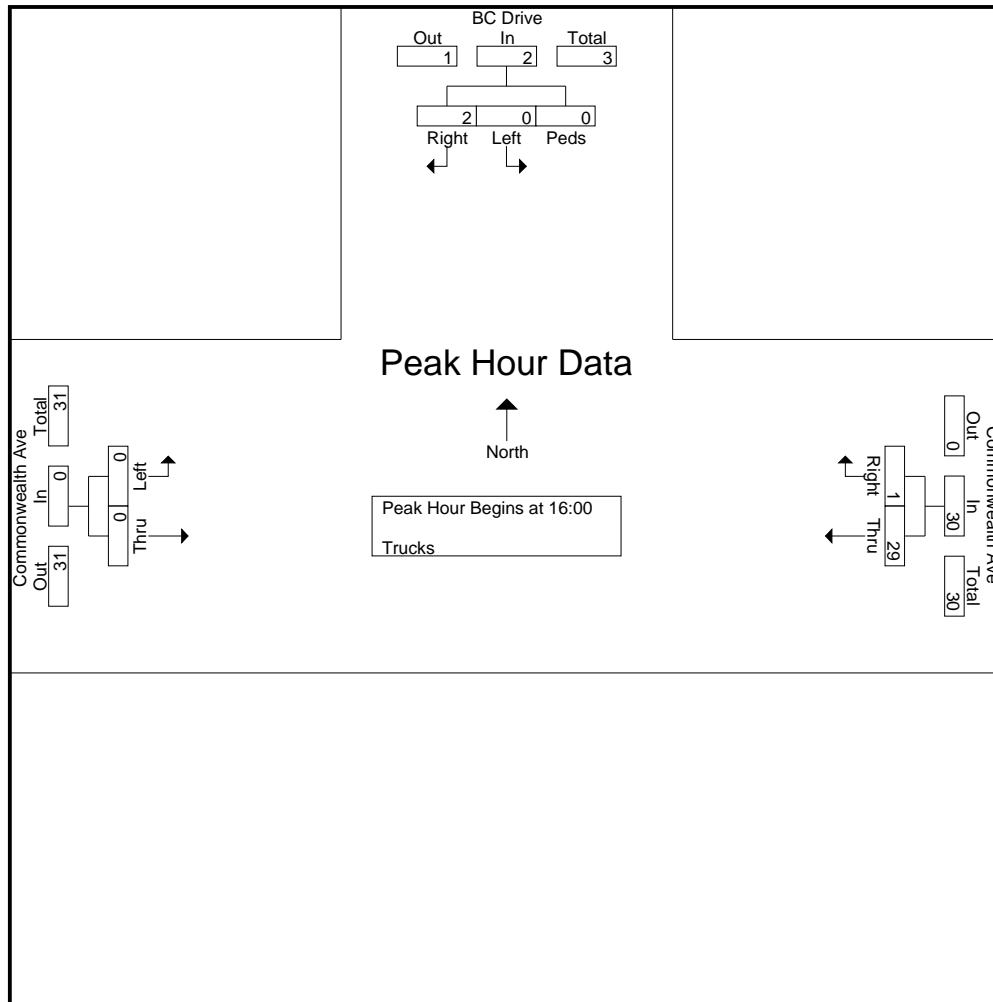

Peak Hour Analysis From 16:00 to 17:45 - Peak 1 of 1

Peak Hour for Each Approach Begins at:

	16:00				16:00			16:00		
+0 mins.	0	0	0	0	6	0	6	0	0	0
+15 mins.	0	0	0	0	8	1	9	0	0	0
+30 mins.	0	2	0	2	8	0	8	0	0	0
+45 mins.	0	0	0	0	7	0	7	0	0	0
Total Volume	0	2	0	2	29	1	30	0	0	0
% App. Total	0	100	0		96.7	3.3		0	0	
PHF	.000	.250	.000	.250	.906	.250	.833	.000	.000	.000

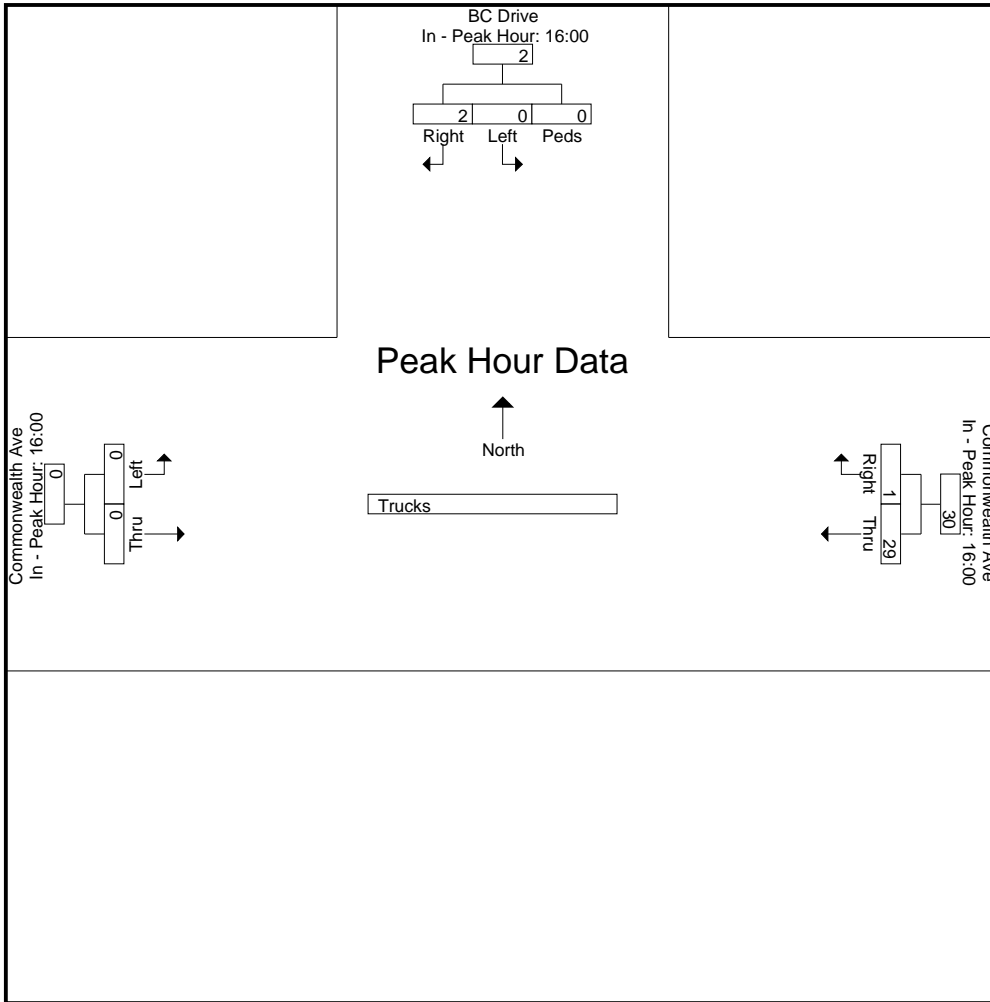

N/S Street : Father Herlihy Drive
E/W Street: St. Thomas More Way
City/State : Brighton, MA
Weather : Clear

Accurate Counts
978-664-2565

File Name : 39000019
Site Code : 39000019
Start Date : 3/25/2008
Page No : 1

Groups Printed- Cars - Trucks

Start Time	Fr Herlihy Dr From North			St Thomas More Way From East			St Thomas More Way From West		
	Left	Right	Peds	Thru	Right	Peds	Left	Thru	Peds

Accurate Counts
978-664-2565

File Name : 39000019
Site Code : 39000019
Start Date : 3/25/2008
Page No : 2

Fr Herlihy Dr

Out	In	Total
0	226	226
0	14	14
0	240	240

164	62
5	9
169	71

Right Left

St Thomas More Way



St Thomas More Way

Out	In	Total
82	247	329
9	8	17
91	255	346

0	247
0	8
0	255

Right Thru

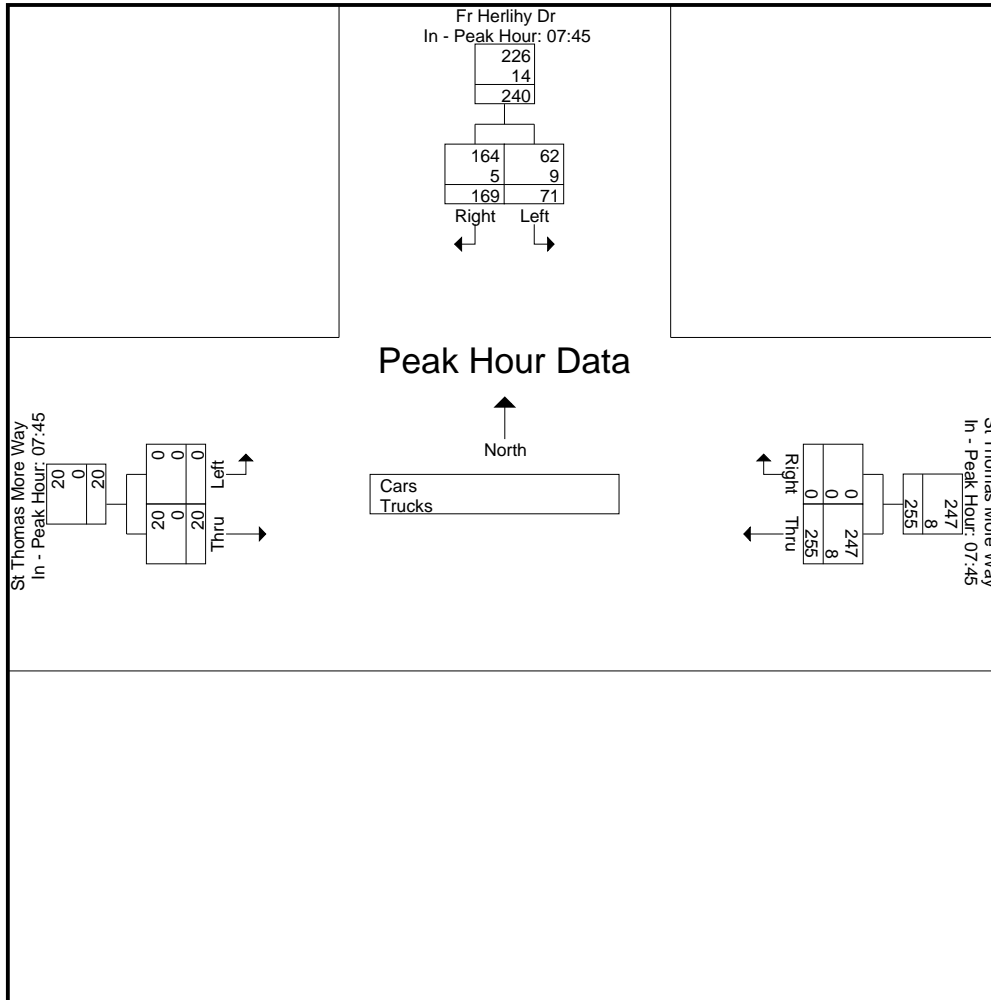

Accurate Counts
978-664-2565

Accurate Counts
978-664-2565

File Name : 39000019
Site Code : 39000019
Start Date : 3/25/2008
Page No : 2

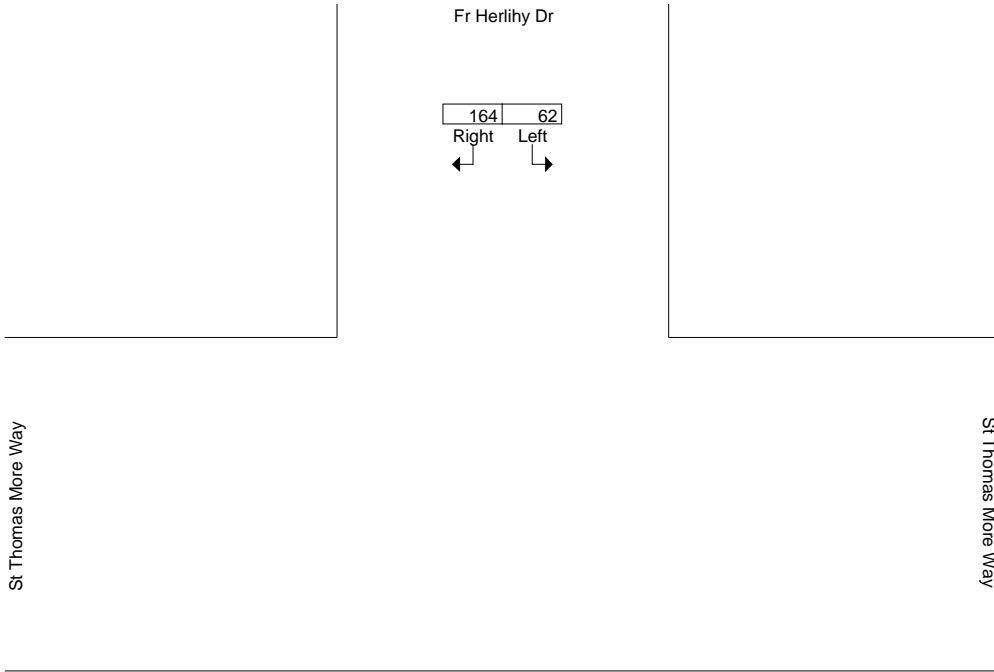

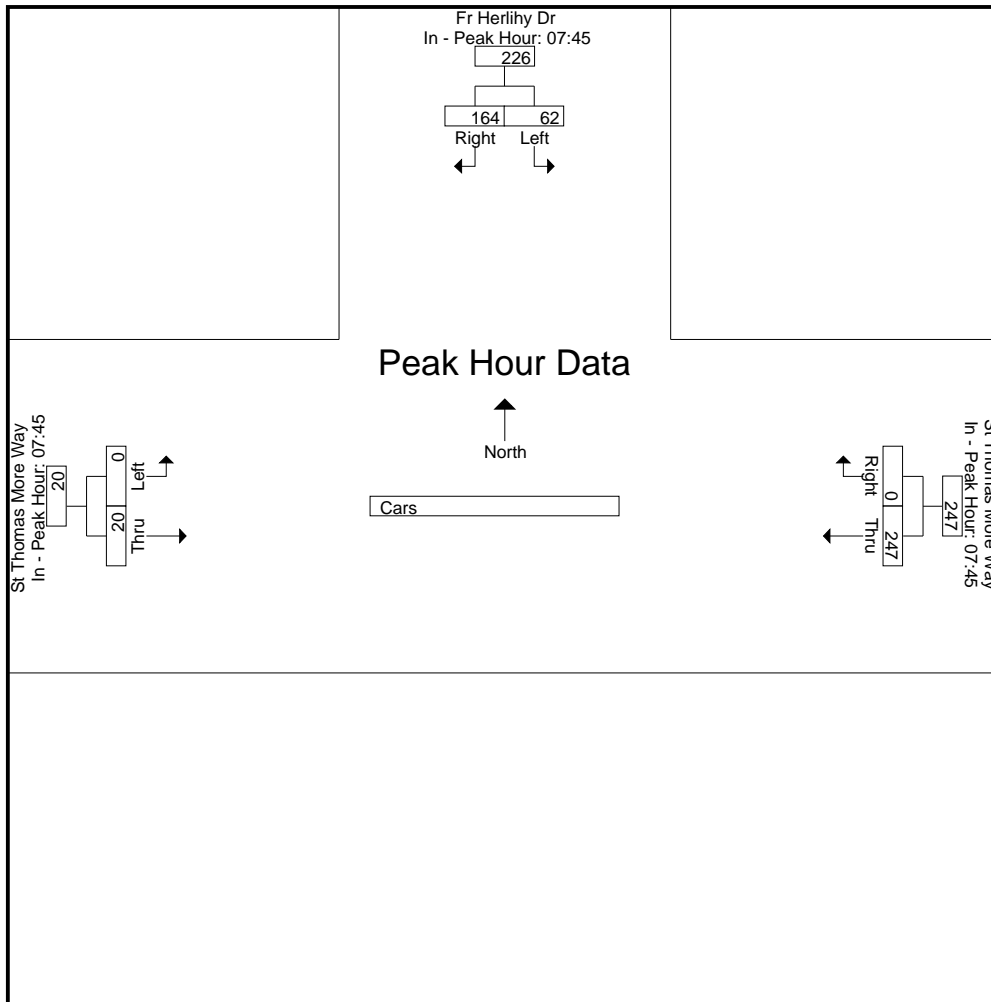

Accurate Counts
978-664-2565

File Name

Accurate Counts
978-664-2565

File Name : 39000019
Site Code : 39000019
Start Date : 3/25/2008
Page No : 2

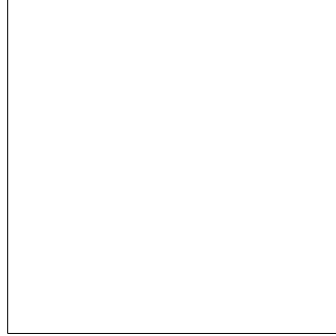

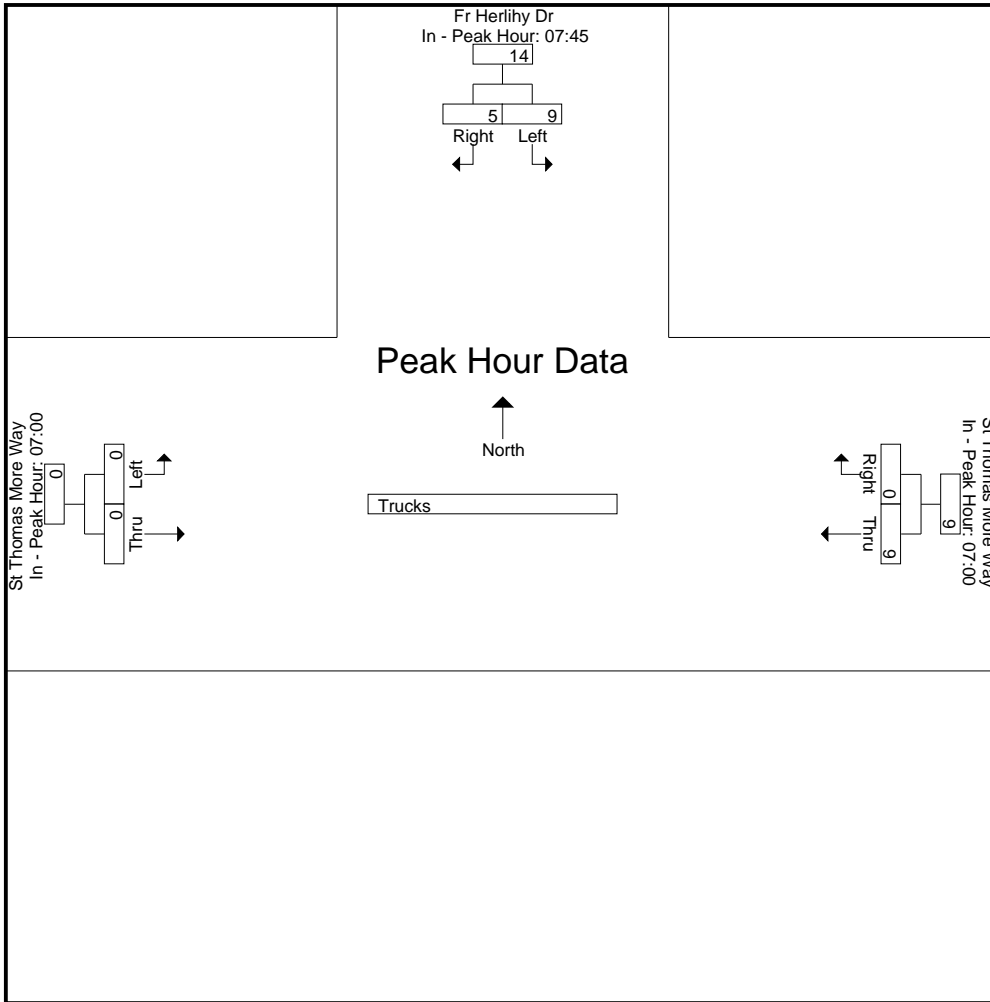

N/S Street : Father Herlihy Drive
E/W Street: St. Thomas More Way
City/State : Brighton, MA

Accurate Counts
978-664-2565

File Name : 39000019
Site Code : 39000019
Start Date : 3/25/2008
Page No : 1

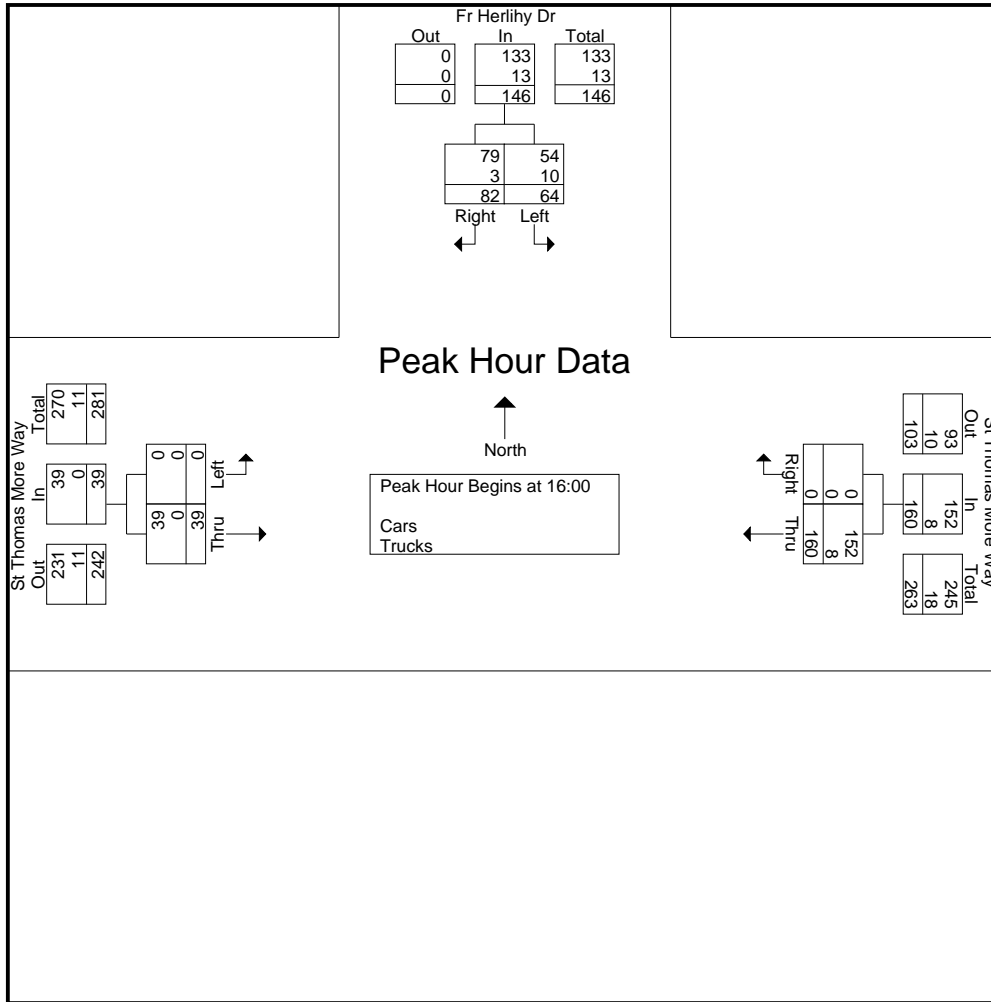

Peak Hour Analysis From 16:00 to 17:45 - Peak 1 of 1

Peak Hour for Each Approach Begins at:

	16:00			16:00			16:00		
+0 mins.	22	25	47	43	0	43	0	16	16
+15 mins.	18	25	43	57	0	57	0	7	7
+30 mins.	9	16	25	23	0	23	0	10	10
+45 mins.	15	16	31	37	0	37	0	6	6
Total Volume	64	82	146	160	0	160	0	39	39
% App. Total	43.8	56.2		100	0		0	100	
PHF	.727	.820	.777	.702	.000	.702			

Accurate Counts
978-664-2565

File Name : 39000019
Site Code : 39000019
Start Date : 3/25/2008
Page No : 3

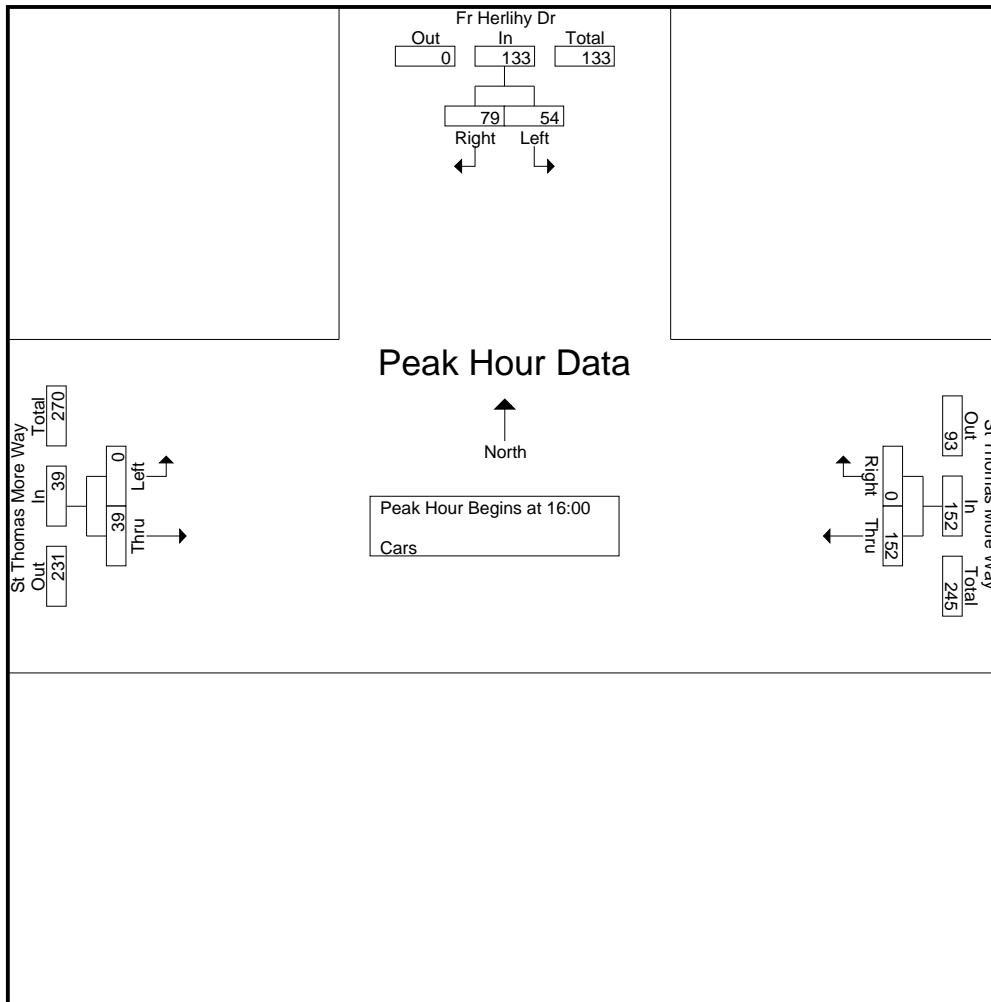

Peak Hour Analysis From 16:00 to 17:45 - Peak 1 of 1

Peak Hour for Each Approach Begins at:

| 16:00

Accurate Counts
978-664-2565

File Name : 39000019
Site Code : 39000019
Start Date : 3/25/2008
Page No : 3

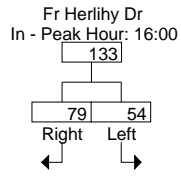

St Thomas More Way



St Thomas More Way

N/S Street : Father Herlihy Drive
 E/W Street: St. Thomas More Way
 City/State : Brighton, MA
 Weather : Clear

Accurate Counts
 978-664-2565

File Name : 39000019
 Site Code : 39000019
 Start Date : 3/25/2008
 Page No : 1

Groups Printed- Trucks

Start Time	Fr Herlihy Dr From North			St Thomas More Way From East			St Thomas More Way From West		
	Left	Right	Peds	Thru	Right	Peds	Left	Thru	Peds

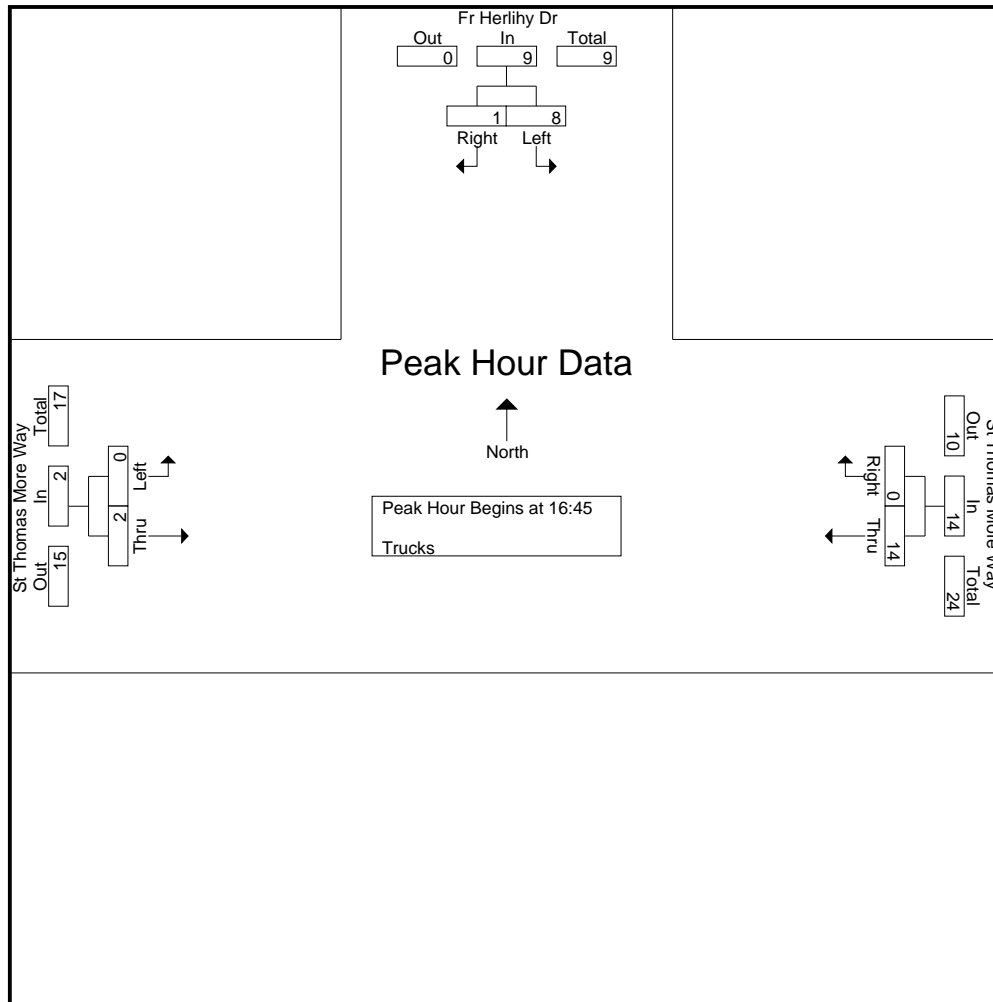

Peak Hour Analysis From 16:00 to 17:45 - Peak 1 of 1

Peak Hour for Each Approach Begins at:

	16:00			16:45			16:45		
+0 mins.	3	2	5	4	0	4	0	0	0
+15 mins.	3	1	4	5	0	5	0	1	1
+30 mins.	2	0	2	2	0	2	0	0	0
+45 mins.	2	0	2	3	0	3	0	1	1
Total Volume	10	3	13	14	0	14	0	2	2
% App. Total	76.9	23.1		100	0		0	100	
PHF	.833	.375	.650	.700	.000	.700	.000	.500	.500

Accurate Counts
978-664-2565

File Name : 39000019
Site Code : 39000019
Start Date : 3/25/2008
Page No : 3

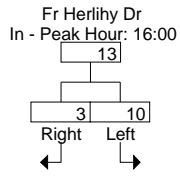

St Thomas More Way

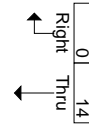

St Thomas More Way

N/S Street : Lake Street
E/W Street: Knowles Street
City/State : Brighton, MA
Weather : Clear

Accurate Counts
978-664-2565

File Name : 39000020
Site Code : 39000020
Start Date : 3/25/2008
Page No : 1

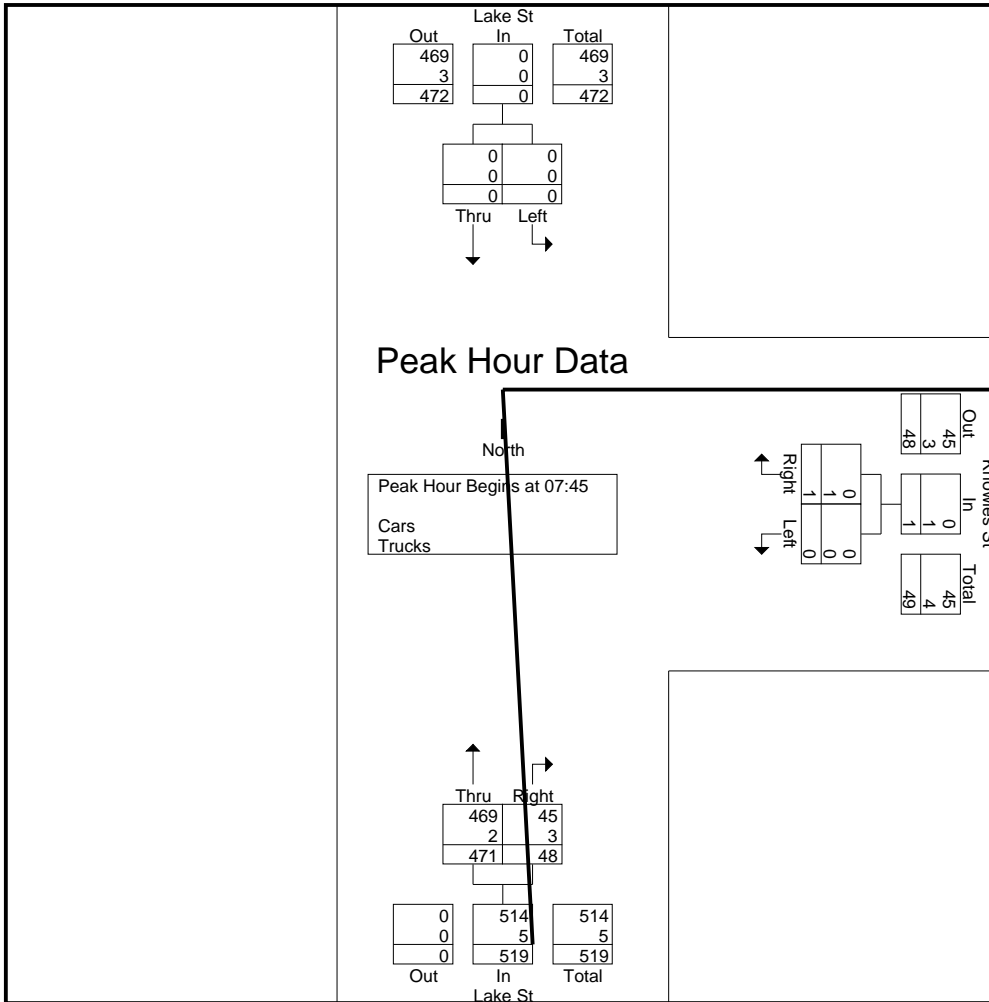

N/S Street : Lake Street
E/W Street: Knowles Street

Accurate Counts
978-664-2565

File Name : 39000020
Site Code : 39000020
Start Date : 3/25/2008
Page No : 1

Accurate Counts
978-664-2565

File Name : 39000020
Site Code : 39000020
Start Date : 3/25/2008
Page No : 2

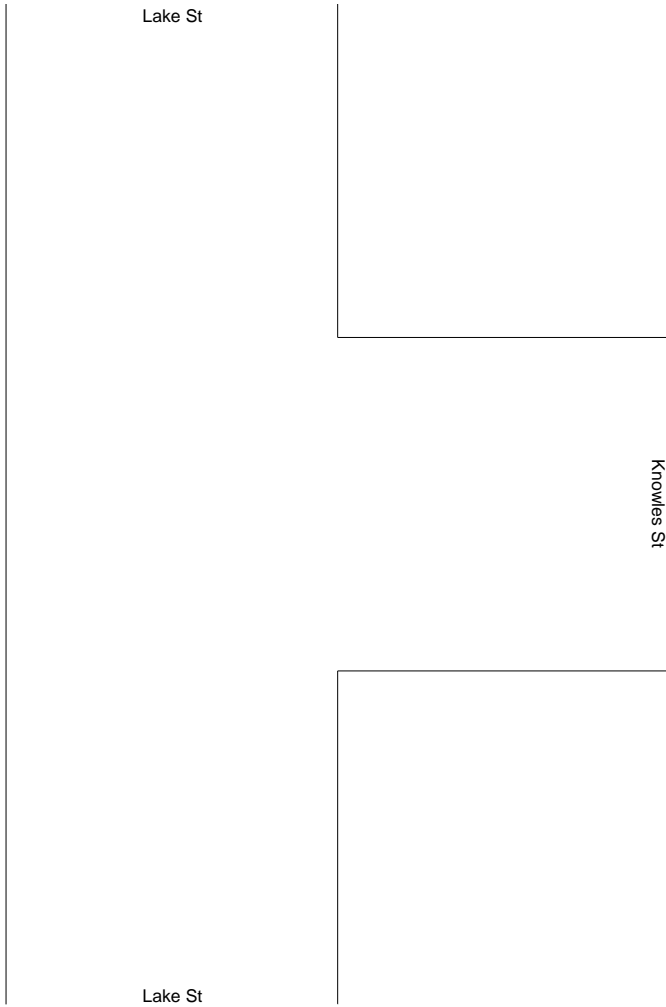

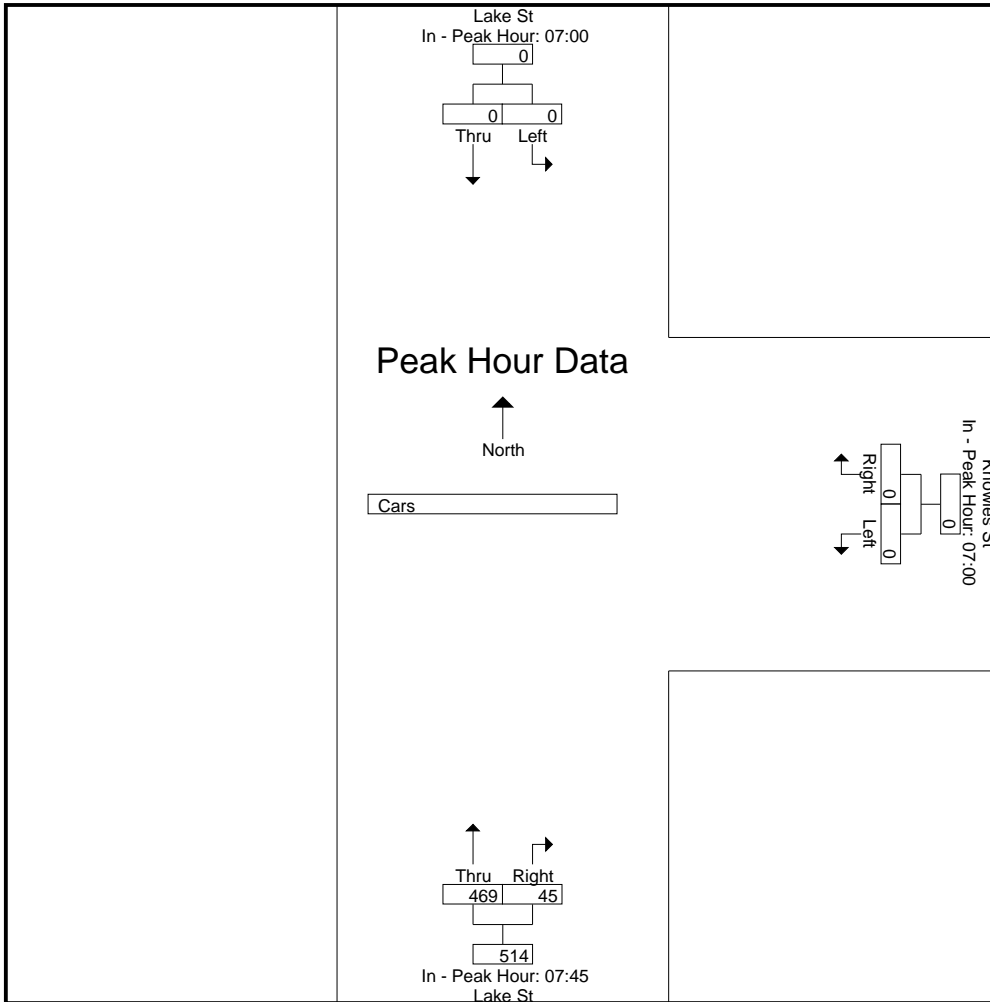

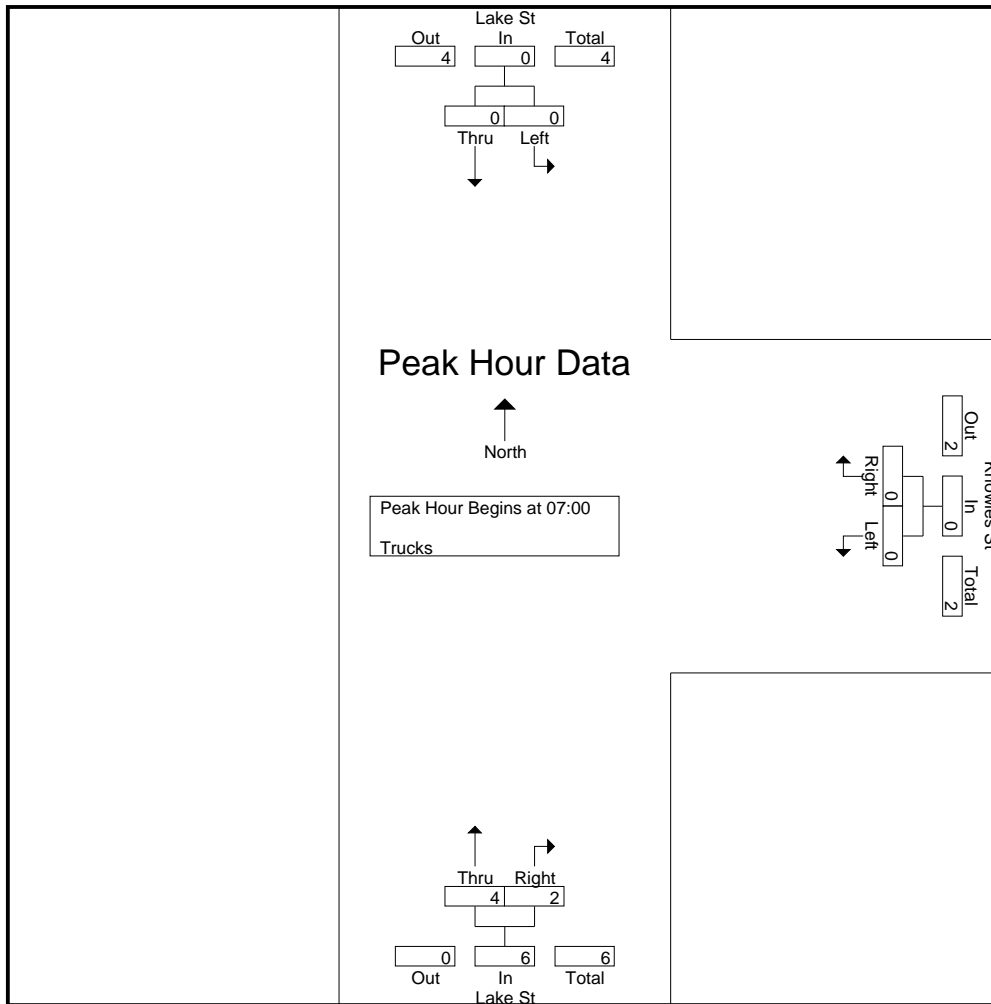

Peak Hour Analysis From 07:00 to 08:45 - Peak 1 of 1

Peak Hour for Each Approach Begins at:

	07:00			07:45			07:00		
+0 mins.	0	0	0	0	0	0	2	0	2
+15 mins.	0	0	0	0	0	0	2	0	2
+30 mins.	0	0	0	0	0	0	0	1	1
+45 mins.	0	0	0	0	1	1	0	1	1
Total Volume	0	0	0	0	1	1	4	2	6
% App. Total	0	0	0	0	100		66.7	33.3	
PHF	.000	.000	.000	.000	.250	.250	.500	.500	.750

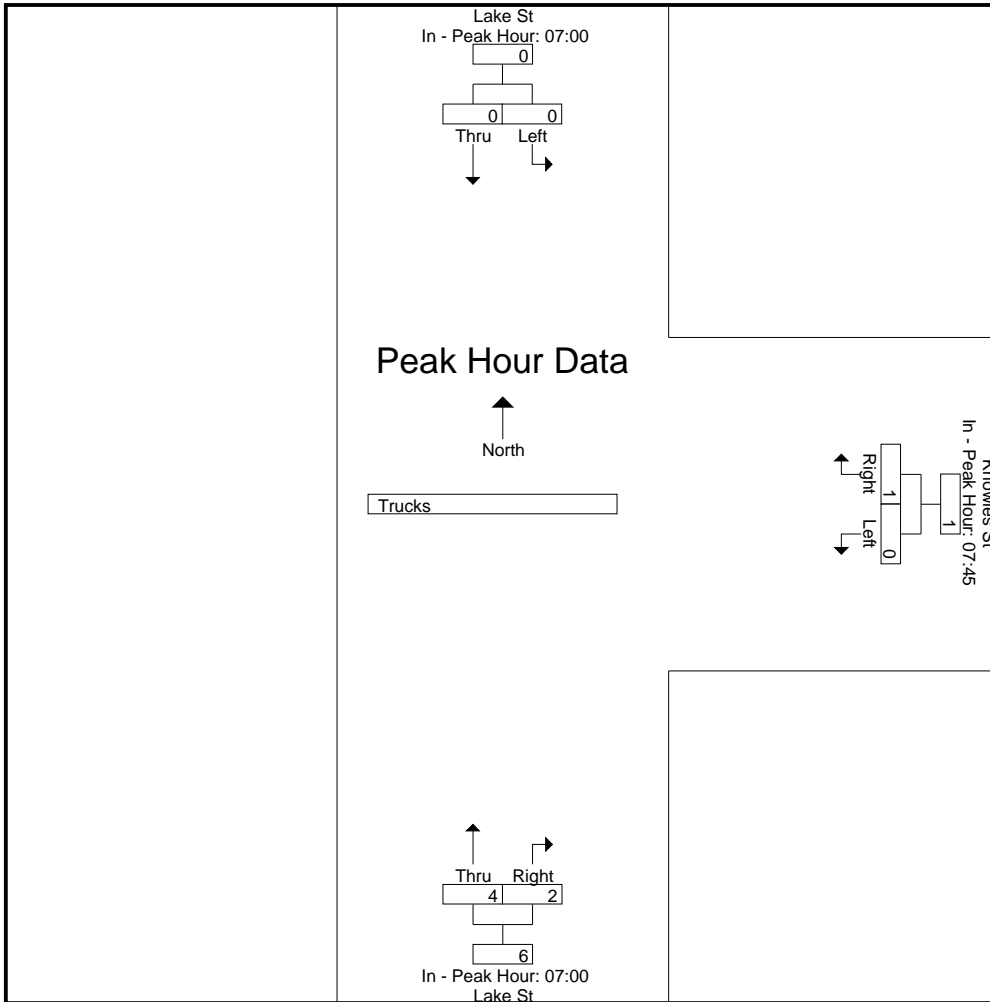

N/S Street : Lake Street
 E/W Street: Knowles Street
 City/State : Brighton, MA
 Weather : Clear

Accurate Counts
 978-664-2565

File Name : 39000020
 Site Code : 39000020
 Start Date : 3/25/2008
 Page No : 1

Groups Printed- Cars - Trucks

Start Time	Lake St From North			Knowles St From East			Lake St From South			Exclu. Total	Inclu. Total	Int. Total
	Left	Thru	Peds	Left	Right	Peds	Thru	Right	Peds			
16:00	0	0	0	0	2	15	114	4	0	15	120	135
16:15	0	0	0	0	1	18	116	7	0	18	124	142
16:30	0	0	0	0	2	13	119	4	0	13	125	138
16:45	0	0	0	0	0	20	116	3	0	20	119	139
Total	0	0	0	0	5	66	465	18	0	66	488	554
17:00	0	0	0	0	0	13	108	1	0	13	109	122
17:15	0	0	0	0	0	22	150	3	0	22	153	175
17:30	0	0	0	0	0	39	110	2	0	39	112	151
17:45	0	0	0	0	0	13	109	0	0	13	109	122
Total	0	0	0	0	0	87	477	6	0	87	483	570
Grand Total	0	0	0	0	5	153	942	24	0	153	971	1124
Apprch %	0	0		0	100		97.5	2.5				
Total %	0	0		0	0.5		97	2.5		13.6	86.4	
Cars	0	0		0	4		936	23		0	0	1116
% Cars	0	0	0	0	80	100	99.4	95.8	0	0	0	99.3
Trucks	0	0		0	1		6	1		0	0	8
% Trucks	0	0	0	0	20	0	0.6	4.2	0	0	0	0.7

Start Time	Lake St From North			Knowles St From East			Lake St From South		
	Left	Thru	App. Total	Left	Right	App. Total	Thru	App. Total	
							5.61	194.16	

Accurate Counts
978-664-2565

File Name : 39000020
Site Code : 39000020
Start Date : 3/25/2008
Page No : 2

Lake St		Total
Out	In	
491	0	491
4	0	4
495	0	495

0	0
0	0
0	0

Thru Left

↓ ↘

1	
1	
2	

Right Left

↘ ↙

Knowles St

Lake St

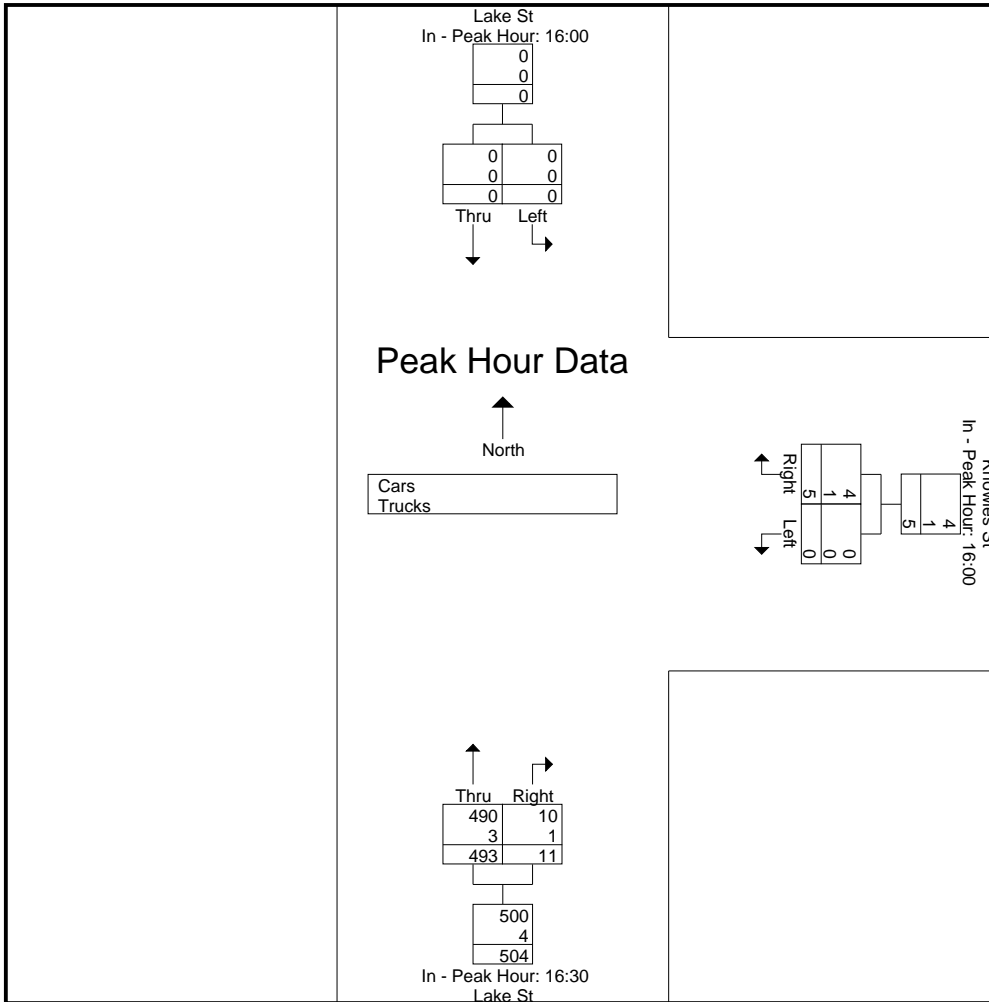

N/S Street : Lake Street
E/W Street: Knowles Street
City/State : Brighton, MA

Accurate Counts
978-664-2565

File Name : 39000020
Site Code : 39000020
Start Date : 3/25/2008
Page No : 1

Accurate Counts

Accurate Counts
978-664-2565

File Name : 39000020
Site Code : 39000020
Start Date : 3/25/2008
Page No : 3

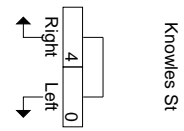
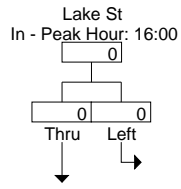

Lake St

Accurate Counts
978-664-2565

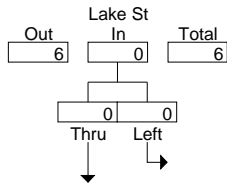

Peak Hour Data

Peak Hour Begins at 16:00
Trucks

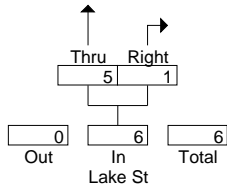
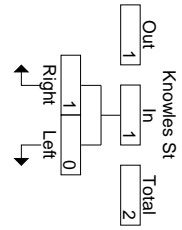

Accurate Counts
978-664-2565

File Name : 39000020
Site Code : 39000020
Start Date : 3/25/2008
Page No : 3

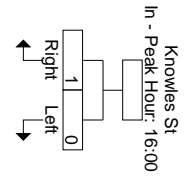
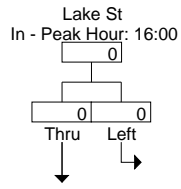

Lake St

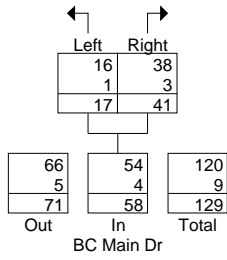
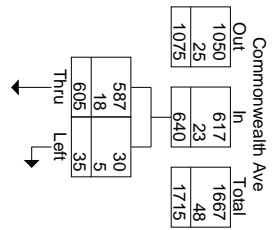
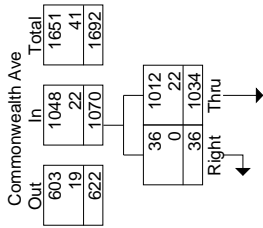

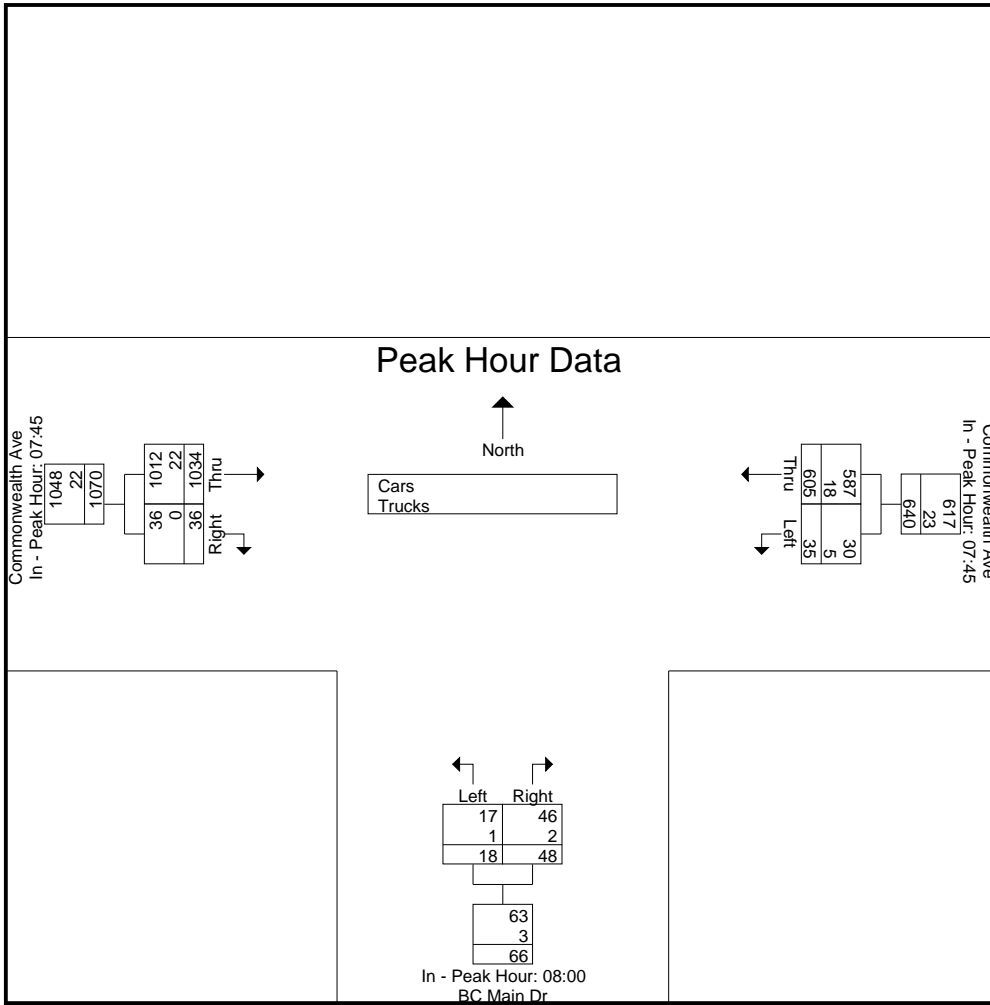

N/S Street : BC Main Drive
E/W Street: Commonwealth Avenue
City/State : Brighton, MA
Weather : Clear

Accurate Counts
978-664-2565

File Name : 39000021
Site Code : 39000021
Start Date : 3/25/2008
Page No : 1

Groups Printed- Cars

	Commonwealth Ave From East		BC Main Dr From South	Commonwealth Ave From West
Start Time	Left	Thru		

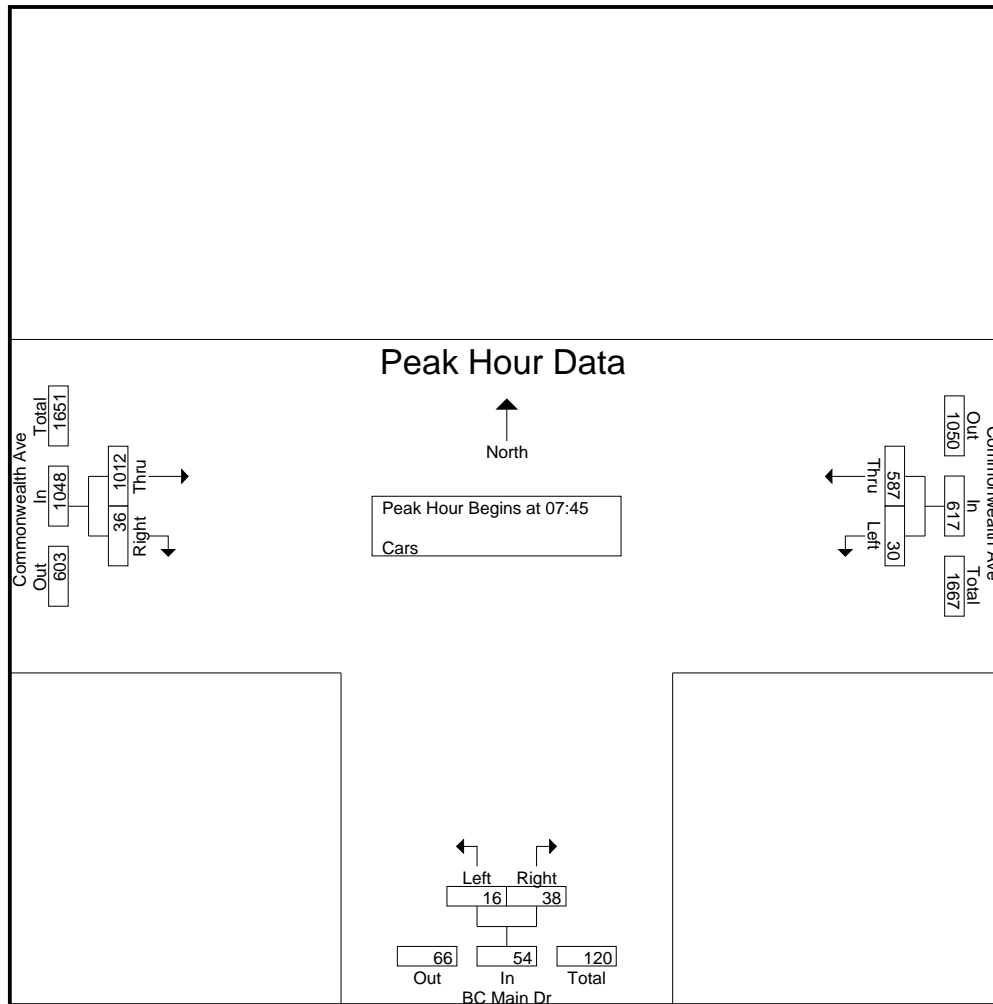

Peak Hour Analysis From 07:00 to 08:45 - Peak 1 of 1

Peak Hour for Each Approach Begins at:

	08:00			08:00			07:45		
+0 mins.	7	159	166	1	4	5	253	14	267
+15 mins.	7	149	156	2	8	10	252	7	259
+30 mins.	9	140	149	12	20	32	262	8	270
+45 mins.	8	140	148	2	14	16	245	7	252
Total Volume	31	588	619	17	46	63	1012	36	1048
% App. Total	5	95		27	73		96.6	3.4	
PHF	.861	.925	.932	.354	.575	.492	.966	.643	.970

N/S Street : BC Main Drive
 E/W Street: Commonwealth Avenue
 City/State : Brighton, MA
 Weather : Clear

Accurate Counts
 978-664-2565

File Name : 39000021
 Site Code : 39000021
 Start Date : 3/25/2008
 Page No : 1

Groups Printed- Trucks

Start Time	Commonwealth Ave From East			BC Main Dr From South			Commonwealth Ave From West			Exclu. Total	Inclu. Total	Int. Total
	Left	Thru	Peds	Left	Right	Peds	Thru	Right	Peds			
07:00	0	4	0	1	0	0	4	1	0	0	10	10
07:15	0	3	0	0	1	0	3	0	0	0	7	7
07:30	0	5	0	0	1	0	6	0	0	0	12	12
07:45	2	4	0	0	1	0	3	0	0	0	10	10
Total	2	16	0	1	3	0	16	1	0	0	39	39
08:00	1	4	0	0	1	0	8	0	0	0	14	14
08:15	0	6	0	0	0	0	5	0	0	0	11	11
08:30	2	4	0	1	1	0	6	0	0	0	14	14
08:45	0	3	0	0	0	0	7	0	0	0	10	10
Total	3	17	0	1	2	0	26	0	0	0	49	49
Grand Total	5	33	0	2	5	0	42	1	0	0	88	88
Apprch %	13.2	86.8		28.6	71.4		97.7	2.3				
Total %	5.7	37.5		2.3	5.7		47.7	1.1		0	100	

Start Time	Commonwealth Ave From East			BC Main Dr From South			Commonwealth Ave From West			Int. Total
	Left	Thru	App. Total	Left	Right	App. Total	Thru	Right	App. Total	
07:45	2	4	6	0	1	1	3	0	3	10
08:00	1	4	5	0	1	1	8	0	8	14
08:15	0	6	6	0	0	0	5	0	5	11
08:30	2	4	6	1	1	2	6	0	6	14
Total Volume	5	18	23	1	3	4				

Peak Hour Analysis From 07:00 to 08:45 - Peak 1 of 1
 Peak Hour for Entire Intersection Begins at 07:45

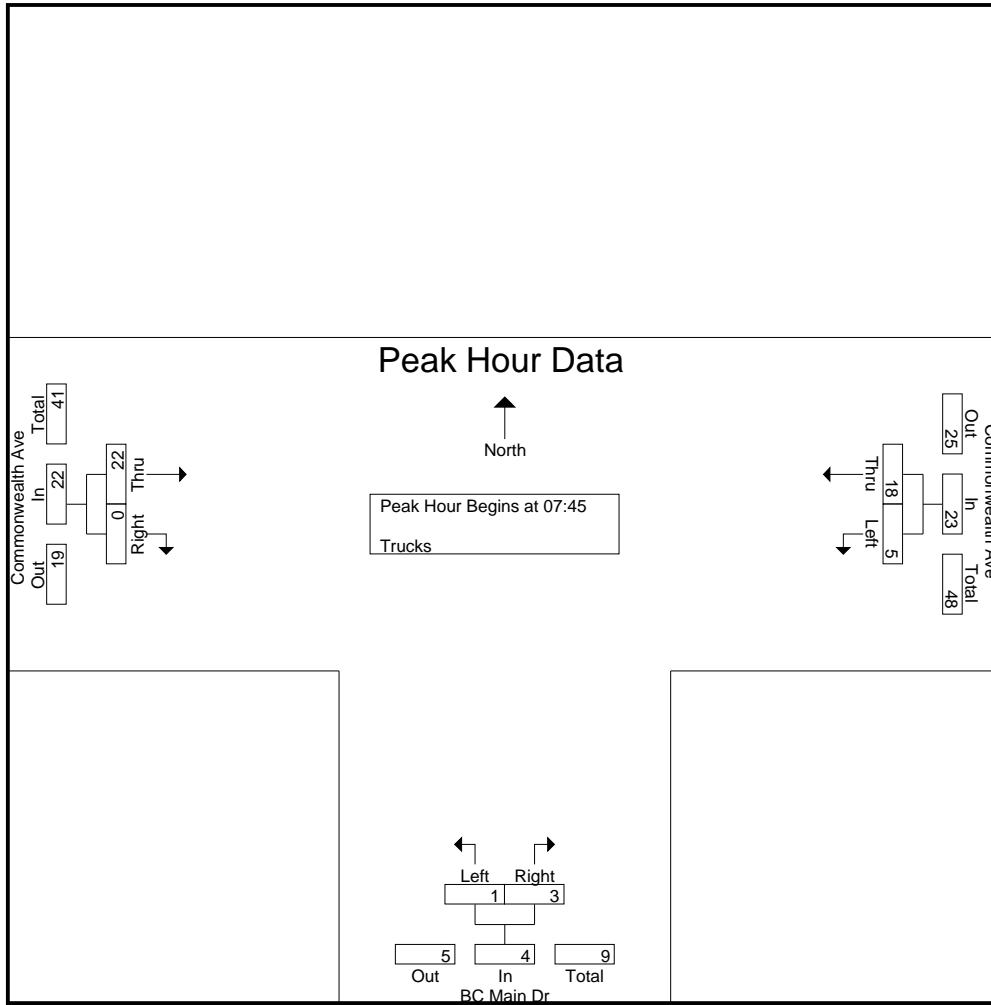

Peak Hour Analysis From 07:00 to 08:45 - Peak 1 of 1

Peak Hour for Each Approach Begins at:

	07:45			07:00			08:00		
+0 mins.	2	4	6	1	0	1	8	0	8
+15 mins.	1	4	5	0	1	1	5	0	5
+30 mins.	0	6	6	0	1	1	6	0	6
+45 mins.	2	4	6	0	1	1	7	0	7
Total Volume	5	18	23	1	3	4	26	0	26
% App. Total	21.7	78.3		25	75		100	0	
PHF	.625	.750	.958	.250	.750	1.000	.813	.000	.813

N/S Street : BC Main Drive
 E/W Street: Commonwealth Avenue
 City/State : Brighton, MA
 Weather : Clear

Accurate Counts
 978-664-2565

File Name : 39000021
 Site Code : 39000021
 Start Date : 3/25/2008
 Page No : 1

Groups Printed- Cars - Trucks

Start Time	Commonwealth Ave From East			BC Main Dr From South			Commonwealth Ave From West			Exclu. Total	Inclu. Total	Int. Total
	Left	Thru	Peds	Left	Right	Peds	Thru	Right	Peds			
16:00	8	148	0	7	9	16	154	10	1	17	336	353
16:15	12	155	2	4	16	10	165	9	1	13	361	374
16:30	9	166	0	3	4	15	168	10	2	17	360	377
16:45	5	142	0	4	10	10	152	9	3	13	322	335
Total	34	611	2	18	39	51	639	38	7	60	1379	1439
17:00	10	173	0	10	13	32	204	15	0	32	425	457
17:15	7	170	2	7	11	16	170	8	2	20	373	393
17:30	6	198	1	6	8	18	208	1	0	19	427	446
17:45	5	172	0	7	17	9	162	7	3	12	370	382
Total	28	713	3	30	49	75	744	31	5	83	1595	1678
Grand Total	62	1324	5	48	88	126	1383	69	12	143	2974	3117
Apprch %	4.5	95.5		35.3	64.7		95.2	4.8				
Total %	2.1	44.5		1.6	3		46.5	2.3		4.6	95.4	
Cars	62	1319		48	88		1353	68		0	0	3081
% Cars	100	99.6	100	100	100	100	97.8	98.6	100	0	0	98.8
Trucks	0	5		0	0		30	1		0	0	36
% Trucks	0	0.4	0	0	0	0	2.2	1.4	0	0	0	1.2

Start Time	Commonwealth Ave From East			BC Main Dr From South			Commonwealth Ave From West	
	Left	Thru	App. Total	Left	Right	App. Total	Thru	Right

Accurate Counts
978-664-2565

File Name : 39000021
Site Code

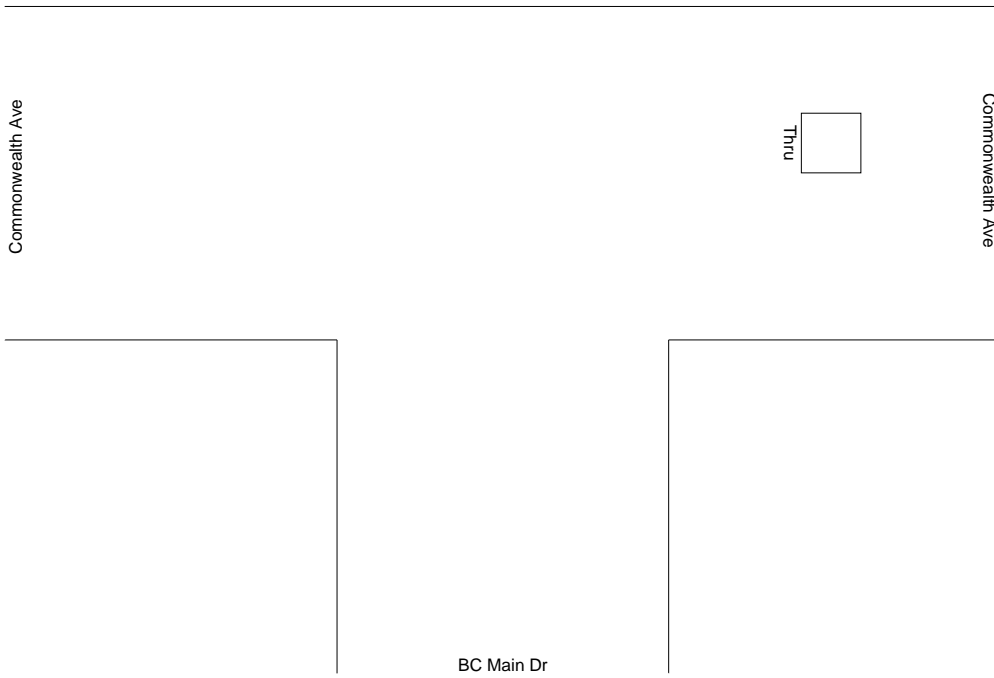

N/S Street : BC Main Drive
E/W Street: Commonwealth Avenue
City/State : Brighton, MA
Weather : Clear

Accurate Counts
978-664-2565

File Name : 39000021
Site Code : 39000021
Start Date : 3/25/2008
Page No : 1

Accurate Counts
978-664-2565

File Name : 39000021
Site Code : 39000021
Start Date : 3/25/2008
Page No : 2

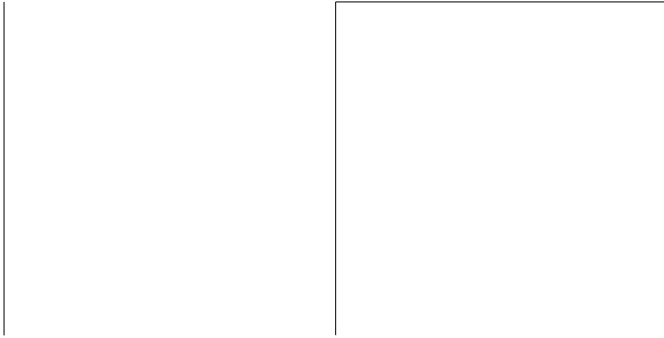

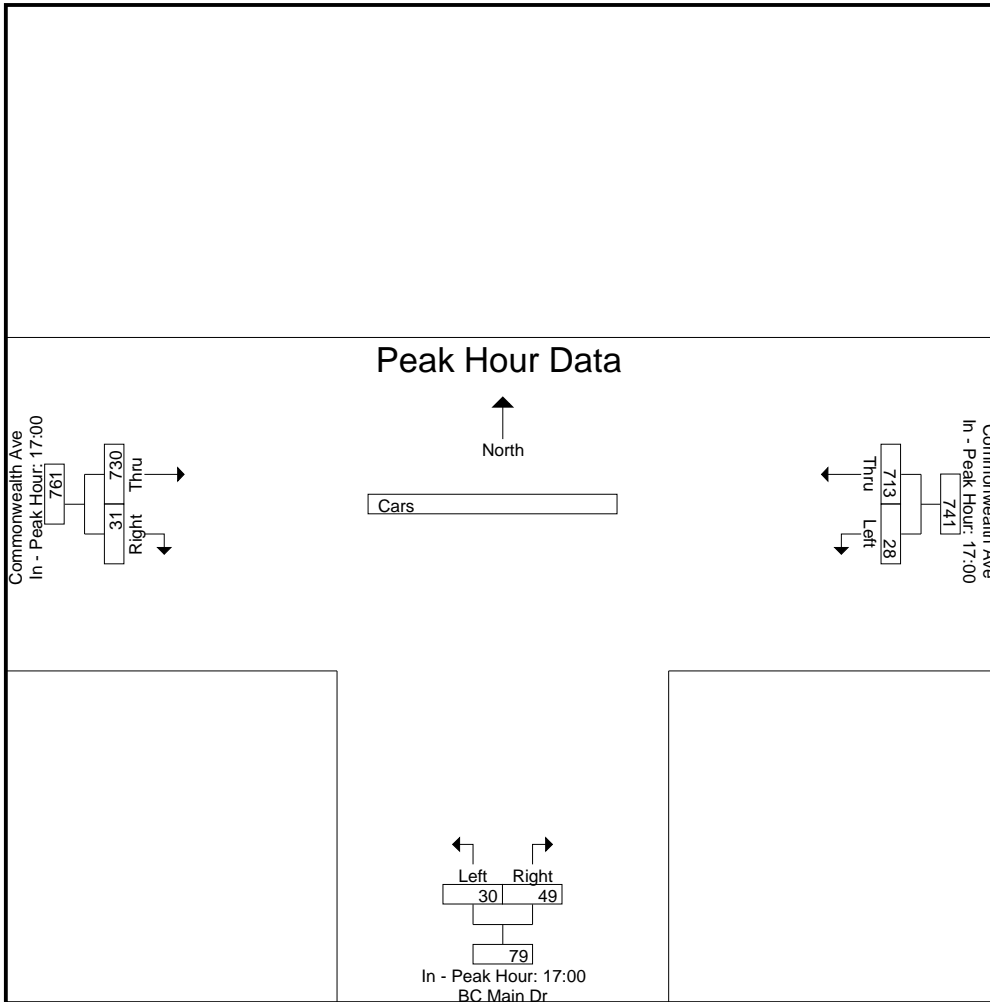

Accurate Counts
978-664-2565

File Name : 39000021

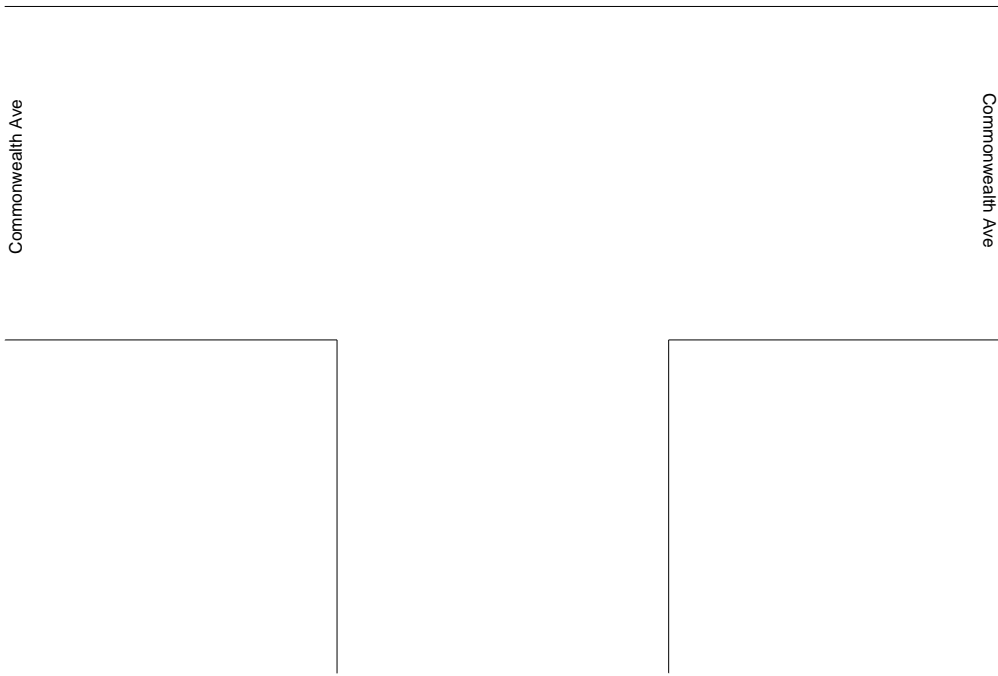

Commonwealth Ave

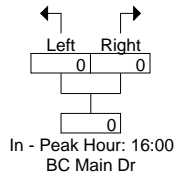
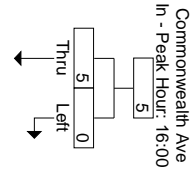

N/S Street : St. Jude Gate

Accurate Counts
978-664-2565

File Name : 39000022
Site Code : 39000022
Start Date : 3/25/2008
Page No : 1

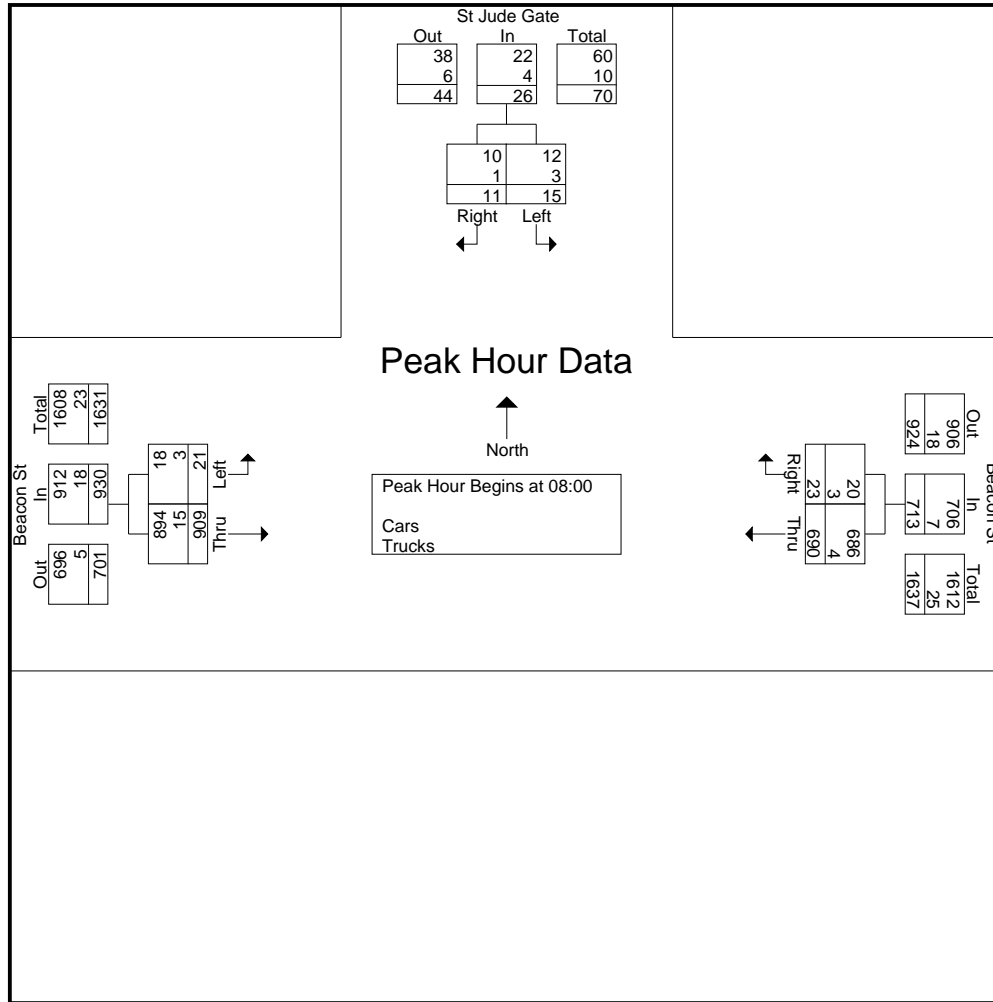

Peak Hour Analysis From 07:00 to 08:45 - Peak 1 of 1

Peak Hour for Each Approach Begins at:

	07:15			08:00			08:00		
+0 mins.	19	7	26	171	6	177	3	229	232
+15 mins.	5	1	6	164	4	168	4	208	212
+30 mins.	4	1	5	177	7	184	7	242	249
+45 mins.	2	2	4	178	6	184	7	230	237
Total Volume	30	11	41	690	23	713	21	909	930
% App. Total	73.2	26.8		96.8	3.2		2.3	97.7	
PHF	.395	.393	.394	.969	.821	.969	.750	.939	.934
Cars	27	10	37	686	20	706	18	894	912
% Cars	90	90.9	90.2	99.4	87	99	85.7	98.3	98.1
Trucks	3	1	4	4	3	7	3	15	18
% Trucks	10	9.1	9.8	0.6	13	1	14.3	1.7	1.9

Accurate Counts
978-664-2565

File Name : 39000022
Site Code : 39000022
Start Date : 3/25/2008
Page No : 3

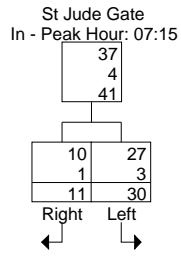

Beacon St

Beacon St

Accurate Counts
978-664-2565

File Name : 39000022
Site Code : 39000022

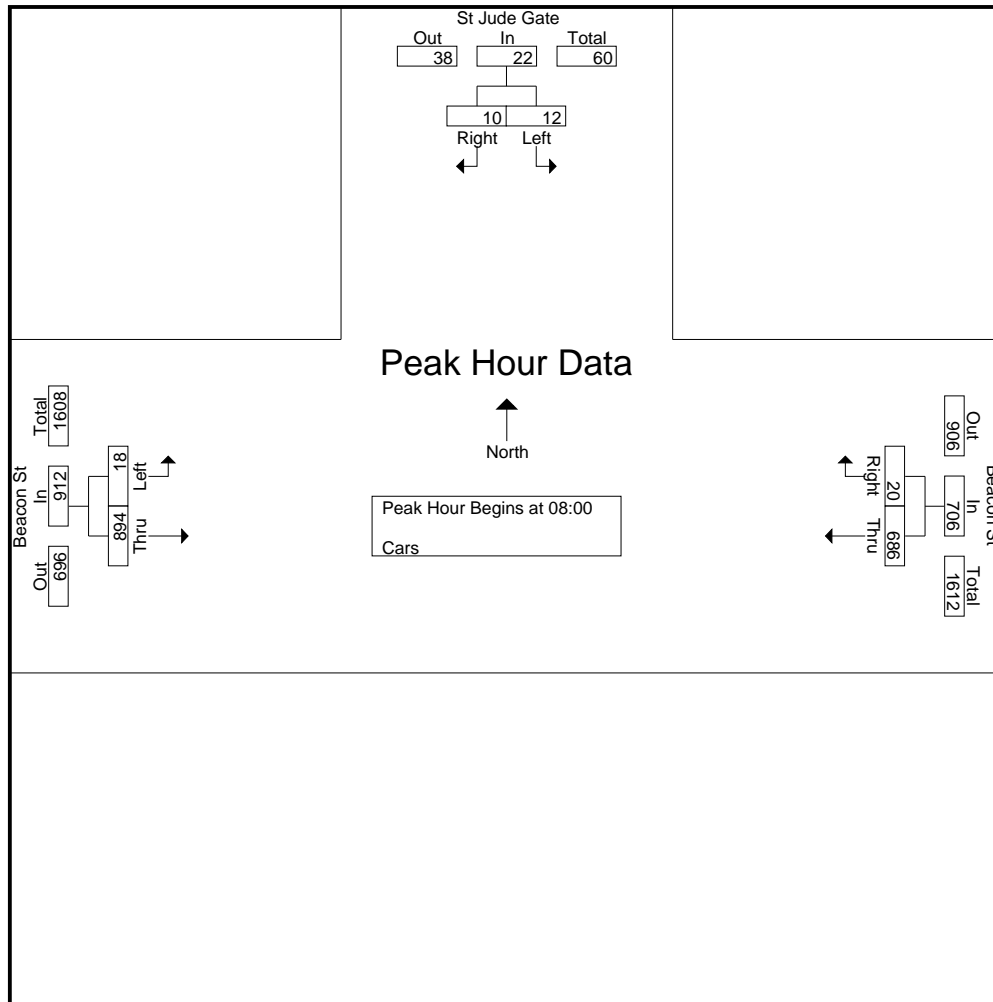

Peak Hour Analysis From 07:00 to 08:45 - Peak 1 of 1

Peak Hour for Each Approach Begins at:

	07:15			08:00			08:00		
+0 mins.	19	7	26	171	5	176	2	227	229
+15 mins.	3	1	4	164	4	168	4	206	210
+30 mins.	4	0	4	175	5	180	5	238	243
+45 mins.	1	2	3	176	6	182	7	223	230
Total Volume	27	10	37	686	20	706	18	894	912
% App. Total	73	27		97.2	2.8		2	98	
PHF	.355	.357	.356	.974	.833	.970	.643	.939	.938

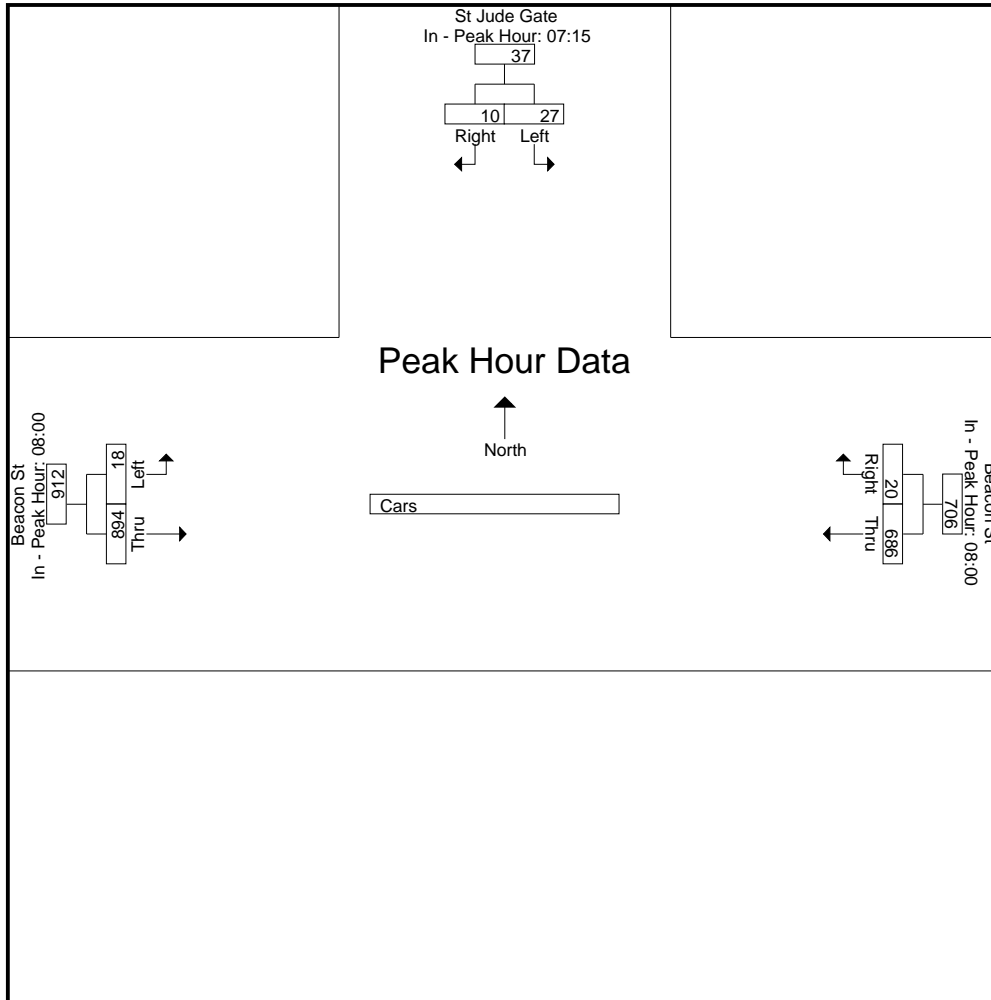

N/S Street : St. Jude Gate
E/W Street: Beacon Street
City/State : Brookline, MA
Weather : Clear

Accurate Counts
978-664-2565

File Name : 39000022
Site Code : 39000022
Start Date : 3/25/2008
Page No : 1

	St Jude Gate
--	--------------

Groups Printed- Trucks

Accurate Counts
978-664-2565

Accurate Counts
978-664-2565

File Name : 39000022
Site Code : 39000022
Start Date : 3/25/2008
Page No : 3

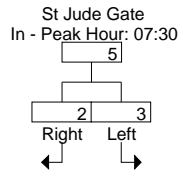

Beacon St



Beacon St

Accurate Counts
978-664-2565

File Name : 39000022
Site Code : 39000022
Start Date : 3/25/2008
Page No : 3

St Jude Gate

Beacon St

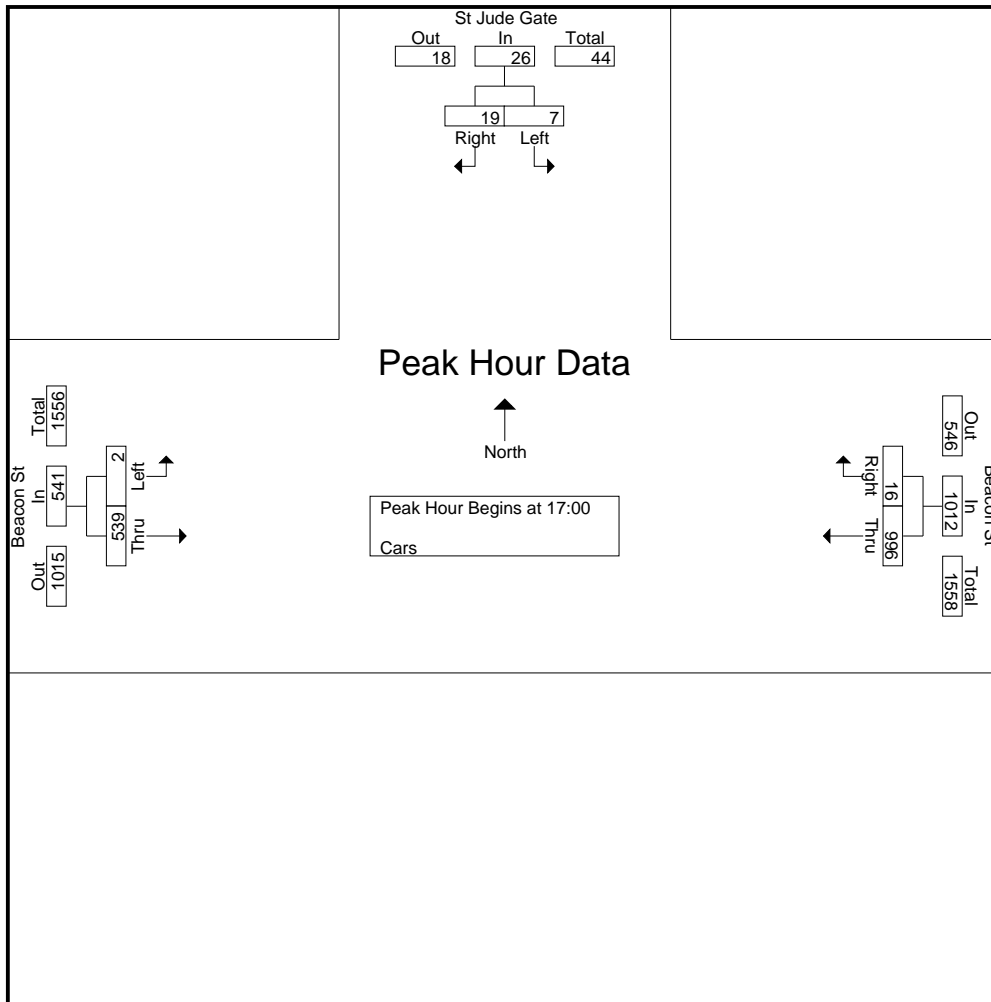

Peak Hour Analysis From 16:00 to 17:45 - Peak 1 of 1

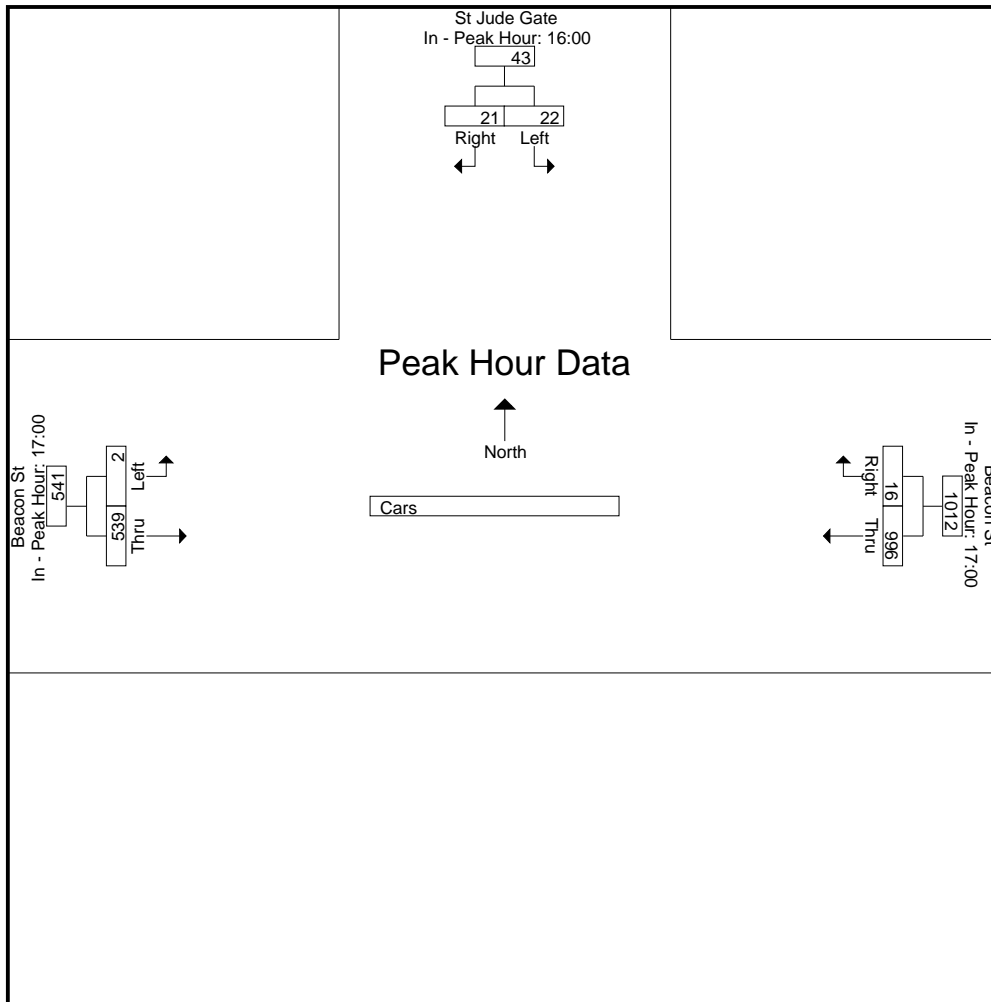

N/S Street : St. Jude Gate
 E/W Street: Beacon Street
 City/State : Brookline, MA
 Weather : Clear

Accurate Counts
 978-664-2565

File Name : 39000022
 Site Code : 39000022
 Start Date : 3/25/2008
 Page No : 1

Groups Printed- Trucks

Start Time	St Jude Gate From North			Beacon St From East			Beacon St From West			Exclu. Total	Inclu. Total	Int. Total
	Left	Right	Peds	Thru	Right	Peds	Left	Thru	Peds			
16:00	0	1	0	11	1	0	0	1	0	0	14	14
16:15	1	0	0	7	0	0	0	1	0	0	9	9
16:30	1	1	0	7	0	0	0	0	0	0	9	9
16:45	0	0	0	6	0	0	1	0	0	0	7	7
Total	2	2	0	31	1	0	1	2	0	0	39	39
17:00	0	0	0	6	0	0	0	0	0	0	6	6
17:15	0	0	0	3	0	0	0	1	0	0	4	4
17:30	0	0	0	7	0	0	0	2	0	0	9	9
17:45	0	0	0	5	0	0	0	0	0	0	5	5
Total	0	0	0	21	0	0	0	3	0	0	24	24
Grand Total	2	2	0	52	1	0	1	5	0	0	63	63
Apprch %	50	50		98.1	1.9		16.7	83.3				
Total %	3.2	3.2		82.5	1.6		1.6	7.9		0	100	

Start Time	St Jude Gate From North			Beacon St From East	Beacon St From West
	Left	Right	App. Total		

Accurate Counts
978-664-2565

File Name : 39000022
Site Code : 39000022
Start Date : 3/25/2008
Page No : 2

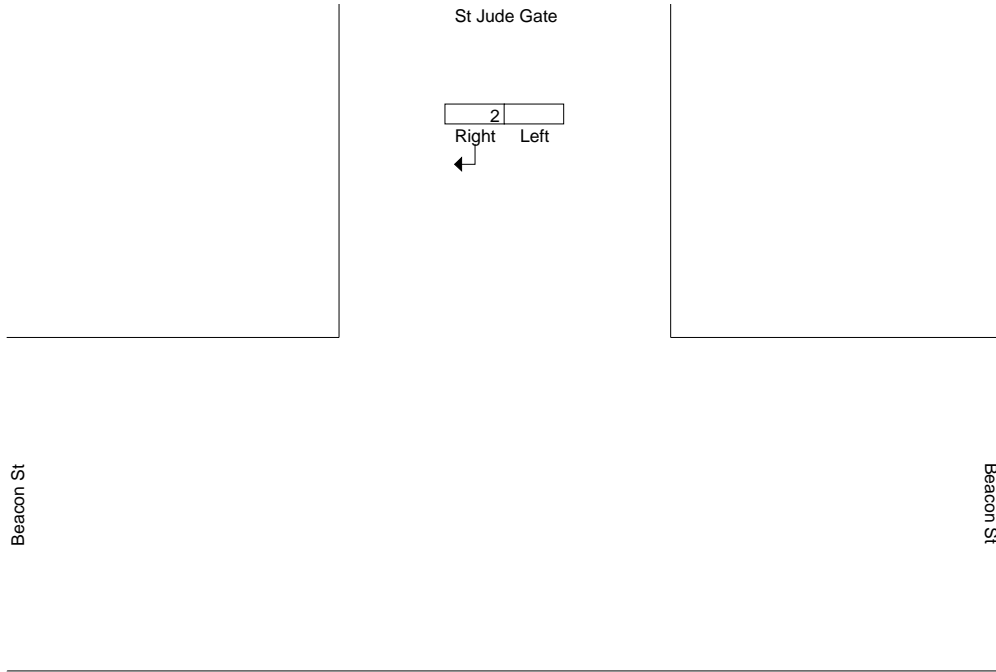

Accurate Counts
978-664-2565

File Name : 39000022
Site Code : 39000022
Start Date : 3/25/2008
Page No : 3

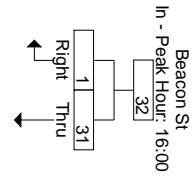
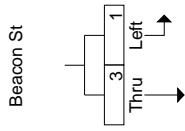
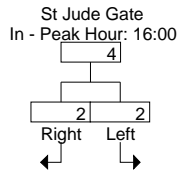

N/S Street : St. Thomas More Road
E/W Street: Chestnut Hill Driveway
City/State : Brighton, MA

Accurate Counts
978-664-2565

File Name : 39000023
Site Code : 39000023
Start Date : 4/9/2008
Page No : 1

Accurate Counts
978-664-2565

File Name : 39000023
Site Code : 39000023
Start Date : 4/9/2008
Page No : 2

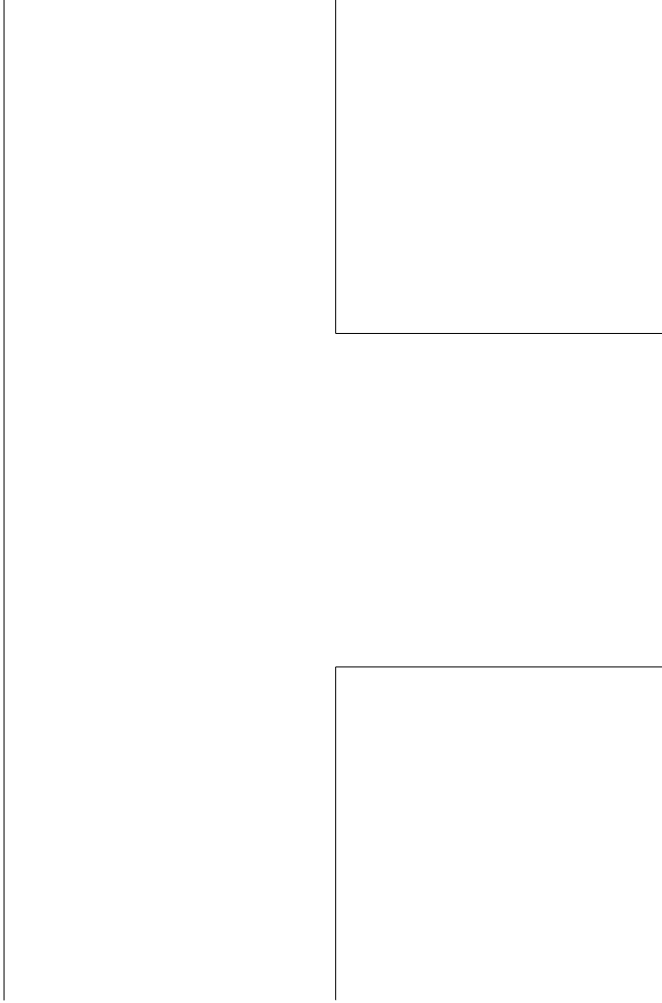

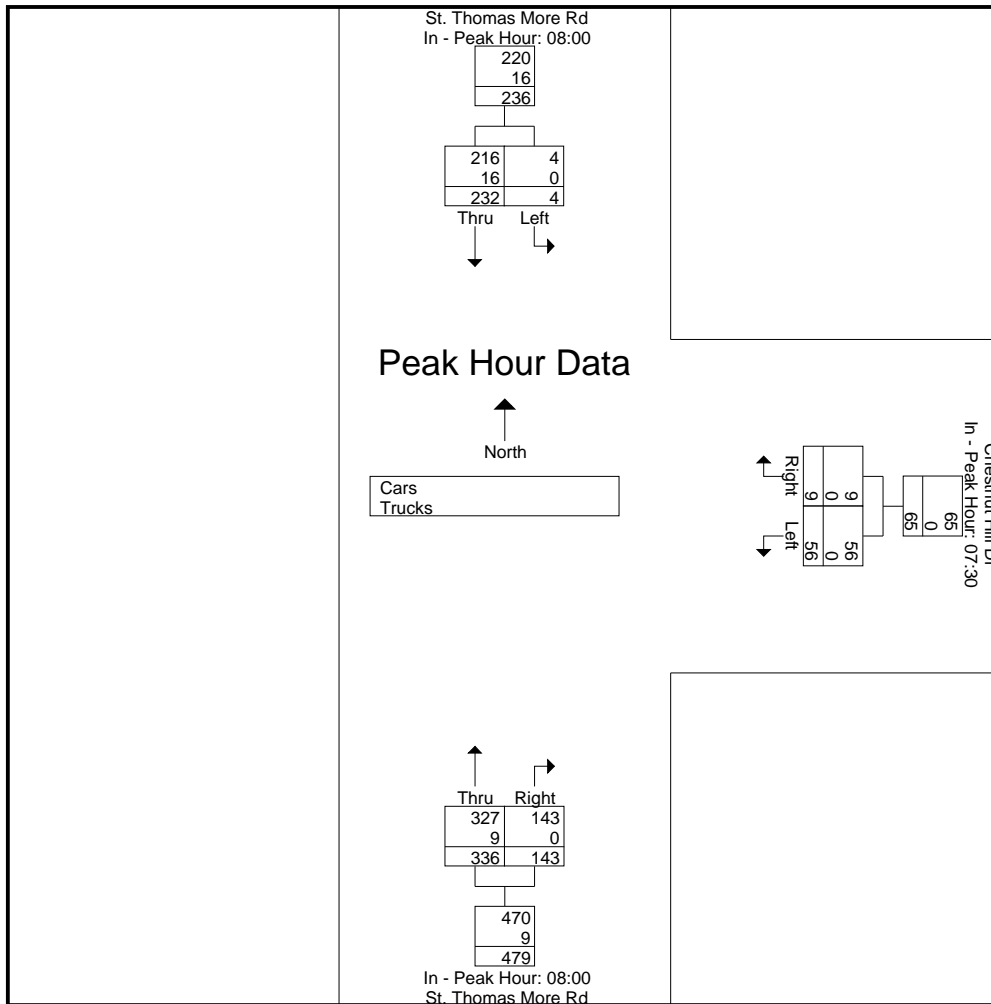

Accurate Counts
978-664-2565

File Name : 39000023
Site Code : 39000023
Start Date : 4/9/2008
Page No : 3

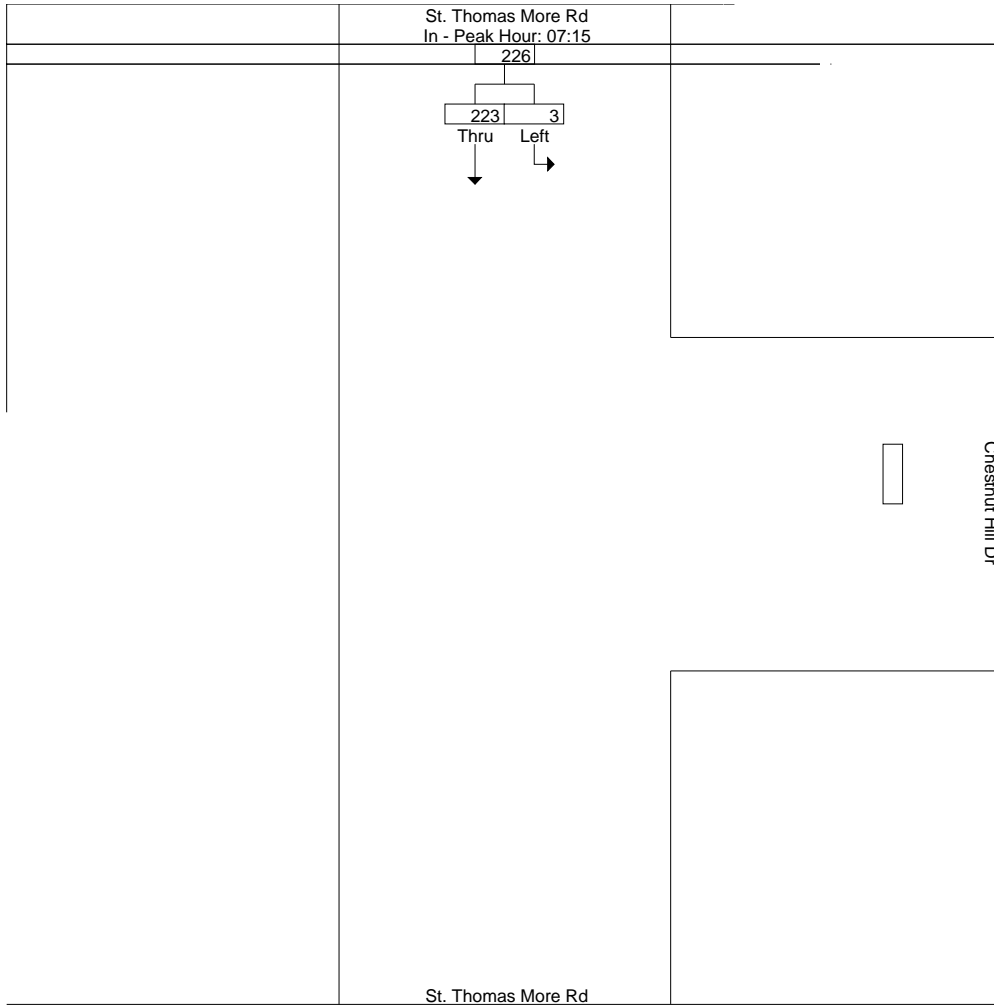

N/S Street : St. Thomas More Road
E/W Street: Chestnut Hill Driveway
City/State : Brighton, MA
Weather : Clear

Accurate Counts
978-664-2565

File Name : 39000023
Site Code : 39000023
Start Date : 4/9/2008
Page No : 1

Groups Printed- Trucks

Start Time	St. Thomas More Rd From North			Chestnut Hill Dr From East		St. Thomas More Rd From South
	Left	Thru	Peds	Left	Right	

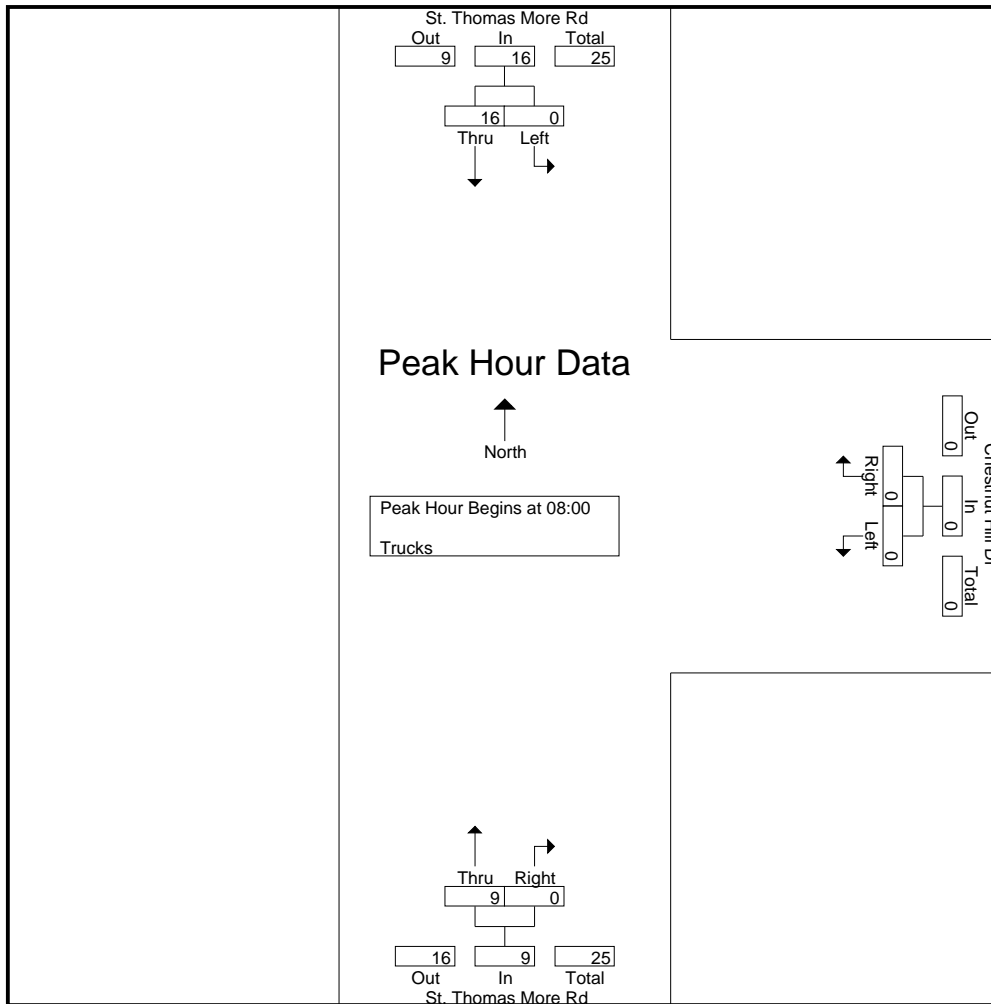

Peak Hour Analysis From 07:00 to 08:45 - Peak 1 of 1

Peak Hour for Each Approach Begins at:

	08:00			07:00			07:45		
+0 mins.	0	4	4	0	0	0	2	0	2
+15 mins.	0	2	2	0	0	0	2	0	2
+30 mins.	0	6	6	0	0	0	3	0	3
+45 mins.	0	4	4	0	0	0	3	0	3
Total Volume	0	16	16	0	0	0	10	0	10
% App. Total	0	100		0	0		100	0	
PHF	.000	.667	.667	.000	.000	.000	.833	.000	.833

Accurate Counts
978-664-2565

File Name : 39000023
Site Code : 39000023
Start Date : 4/9/2008
Page No : 3

St. Thomas More Rd
In - Peak Hour: 08:00

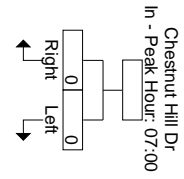
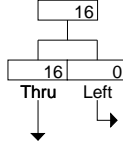

St. Thomas More Rd

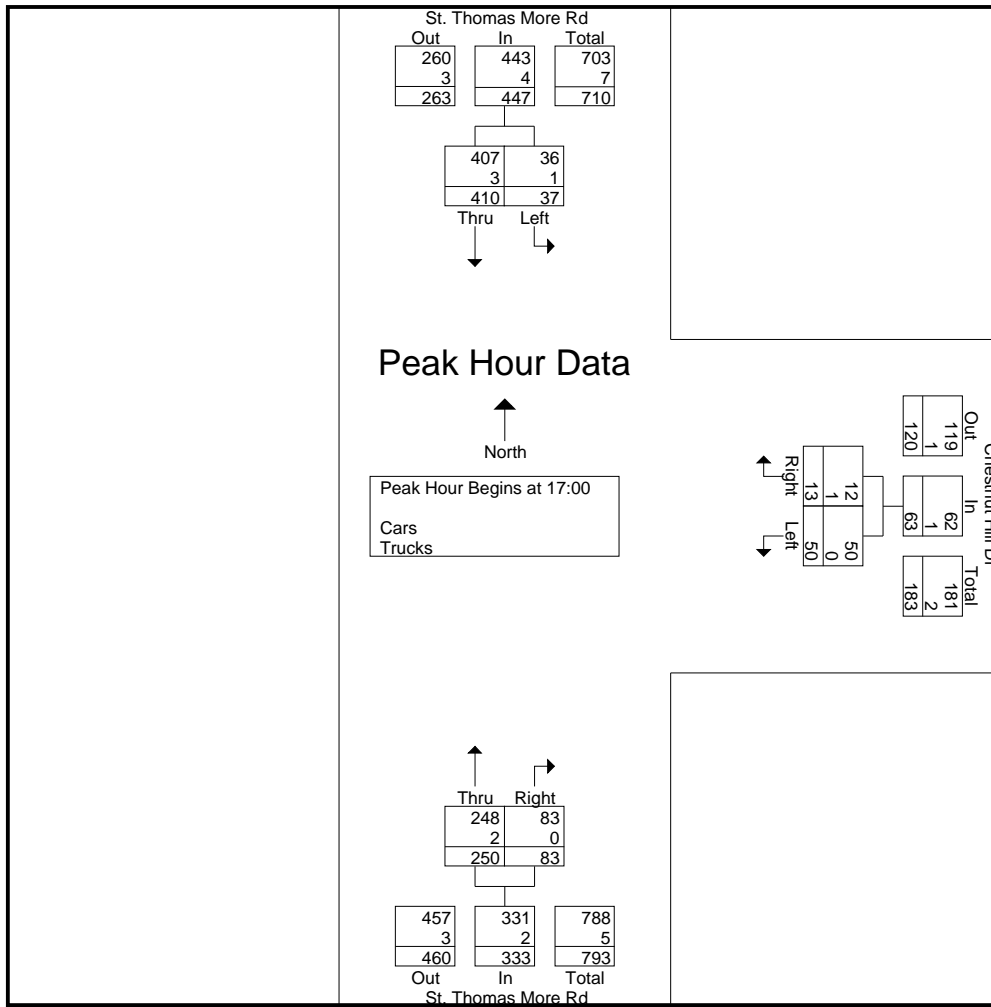

Peak Hour Analysis From 16:00 to 17:45 - Peak 1 of 1

Peak Hour for Each Approach Begins at:

	17:00			16:00			17:00		
+0 mins.	11	96	107	15	2	17	55	15	70
+15 mins.	8	108	116	16	1	17	75	20	95
+30 mins.	5	102	107	23	2	25	56	27	83
+45 mins.	13	104	117	14	3	17	64	21	85
Total Volume	37	410	447	68	8	76	250	83	333
% App. Total	8.3	91.7		89.5	10.5		75.1	24.9	
PHF	.712	.949	.955	.739	.667	.760	.833	.769	.876
Cars	36	407	443	68	8	76	248	83	331
% Cars	97.3	99.3	99.1	100	100	100	99.2	100	99.4
Trucks	1	3	4	0	0	0	2	0	2
% Trucks	2.7	0.7	0.9	0	0	0	0.8	0	0.6

Accurate Counts
978-664-2565

File Name : 39000023
Site Code : 39000023
Start Date : 4/9/2008
Page No : 3

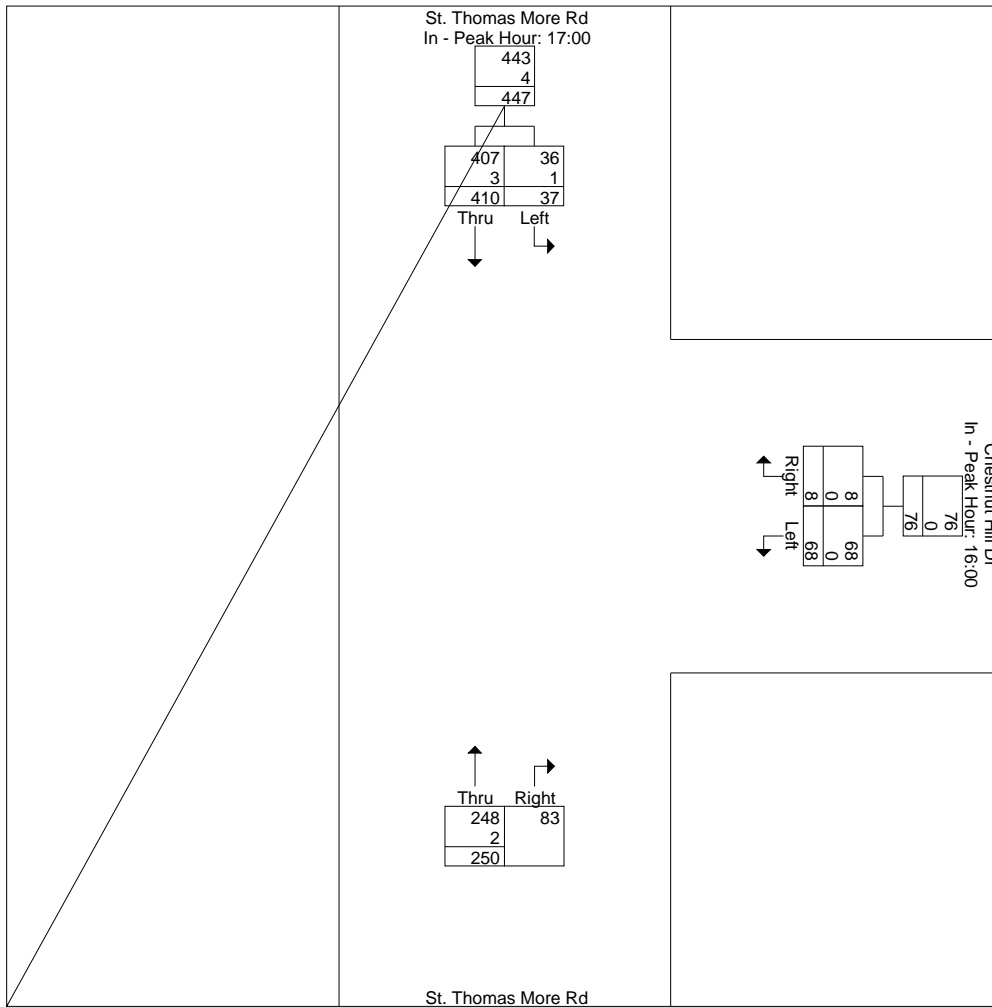

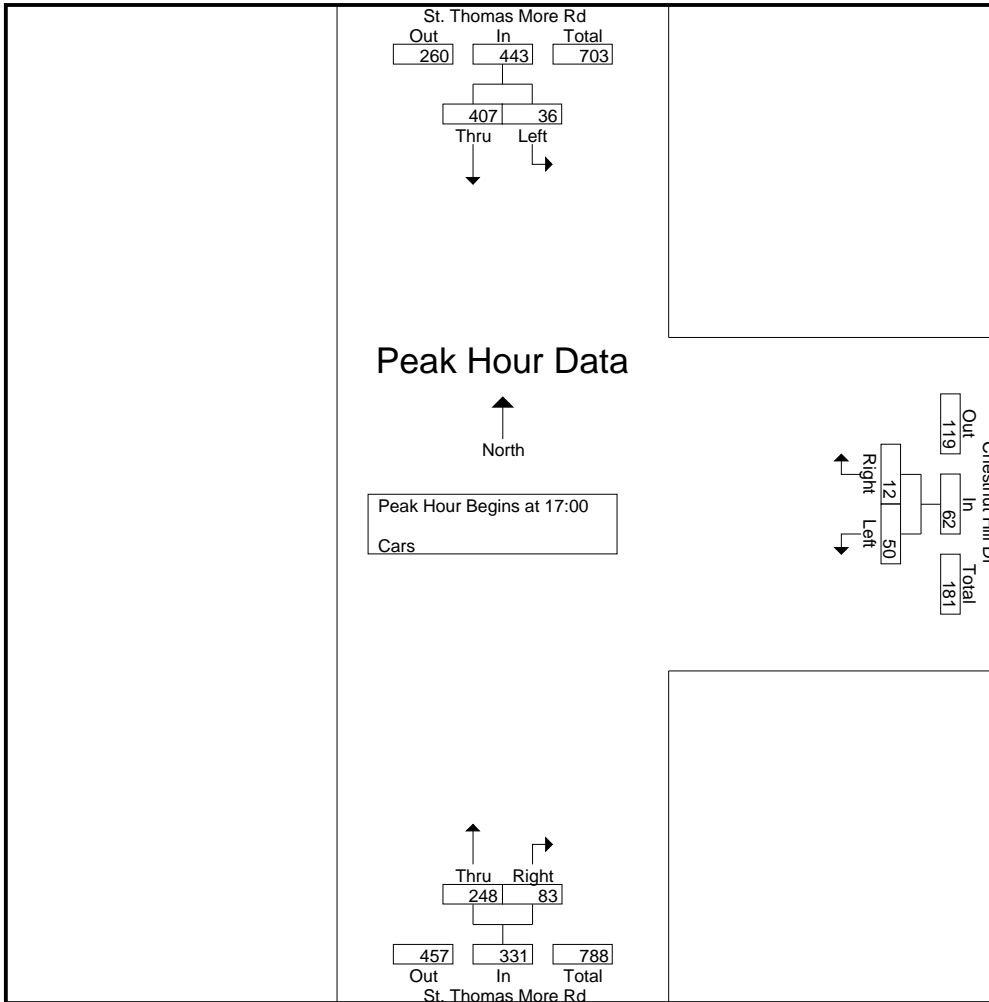

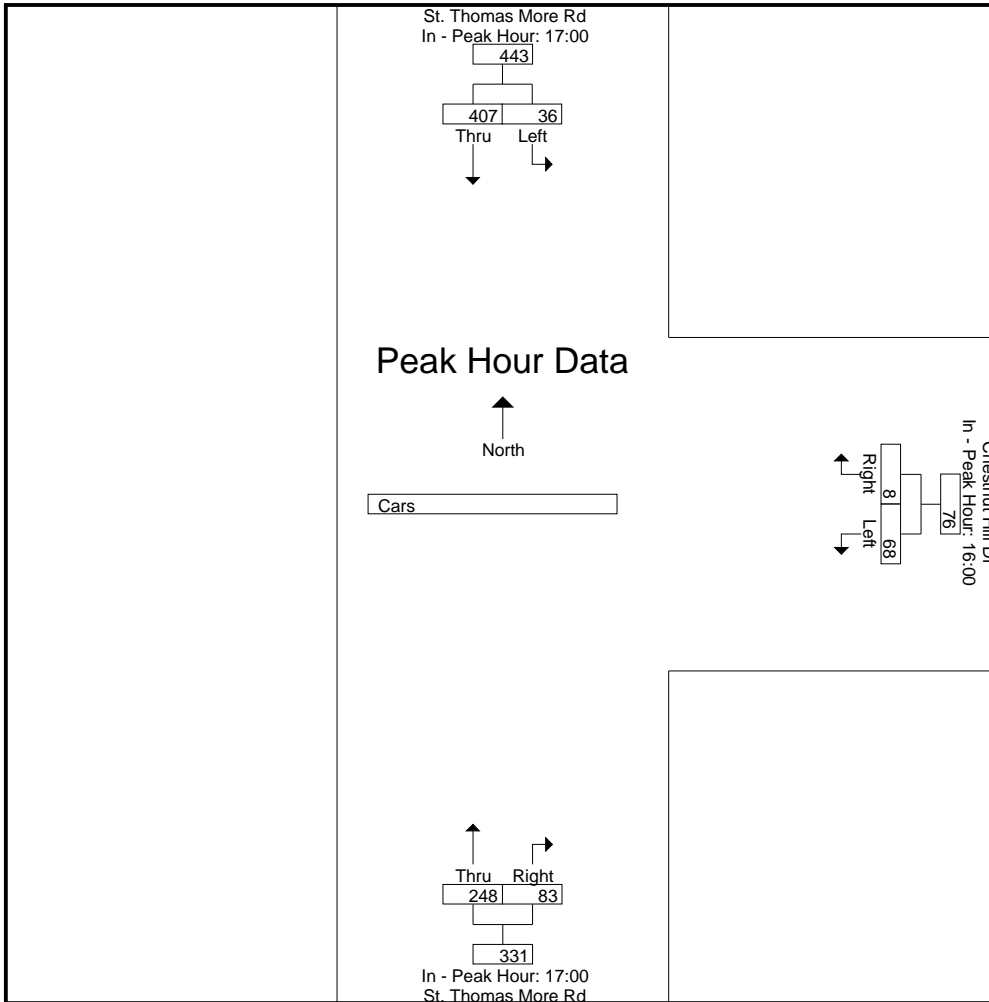

N/S Street : St. Thomas More Road
 E/W Street: Chestnut Hill Driveway
 City/State : Brighton, MA
 Weather : Clear

Accurate Counts
 978-664-2565

File Name : 39000023
 Site Code : 39000023
 Start Date : 4/9/2008
 Page No : 1

Groups Printed- Trucks

Start Time	St. Thomas More Rd From North			Chestnut Hill Dr From East			St. Thomas More Rd From South			Exclu. Total	Inclu. Total	Int. Total
	Left	Thru	Peds	Left	Right	Peds	Thru	Right	Peds			
16:00	0	0	0	0	0	0	0	0	0	0	0	0
16:15	0	0	0	0	0	0	0	0	0	0	0	0
16:30	0	1	0	0	0	0	0	0	0	0	1	1
16:45	0	1	0	0	0	0	0	0	0	0	1	1
Total	0	2	0	0	0	0	0	0	0	0	2	2
17:00	0	0	0	0	0	0	0	0	0	0	0	0
17:15	0	0	0	0	0	0	0	0	0	0	0	0
17:30	0	1	0	0	0	0	1	0	0	0	2	2
17:45	1	2	0	0	1	0	1	0	0	0	5	5
Total	1	3	0	0	1	0	2	0	0	0	7	7
Grand Total	1	5	0	0	1	0	2	0	0	0	9	9
Apprch %	16.7	0 s6 535-9..76 - s6 535-08.17.64 517.434f - s6 516 554.45 1 SS Bd -8 Ts (2) Tj E- s6 516 554.45 0 08 m9ET5E- s6 5.98 m9ET5E08.17.64										

Accurate Counts
978-664-2565

File Name : 39000023
Site Code : 39000023
Start Date : 4/9/2008
Page No : 2

St. Thomas More Rd

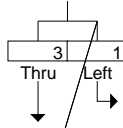

Chestnut Hill Dr

St. Thomas More Rd

N/S Street : Lake St / St Thomas Moore
 E/W Street: Commonwealth Avenue
 City/State : Brighton, MA
 Weather : Clear

Accurate Counts
 978-664-2565

File Name : 390000B1
 Site Code : 39000001
 Start Date : 5/1/2008
 Page No : 1

Groups Printed- Cars

Start Time	Lake St From North			Commonwealth Ave From East			St Thomas Moore Rd From South			Commonwealth Ave From West			Int. Total
	Left	Thru	Right	Left	Thru	Right	Left	Thru	Right	Left	Thru	Right	
07:00	0	0	0	0	1	0	0	0	0	0	1	0	2
07:15	0	0	0	0	1	0	0	1	0	0	2	0	4
07:30	0	0	0	0	0	0	0	0	0	0	1	0	1
07:45	0	0	0	0	0	0	0	1	0	0	0	0	1
Total	0	0	0	0	2	0	0	2	0	0	4	0	8
08:00	0	0	0	0	0	0	0	1	0	0	1	0	2
08:15	0	2	0	0	0	0	0	0	0	0	0	0	2
08:30	0	0	0	2	0	0	0	0	0	0	0	0	2
08:45	0	0	0	1	4	0	0	0	0	0	3	0	8
Total	0	2	0	3	4	0	0	1	0	0	4	0	14
Grand Total	0	2	0	3	6	0	0	3	0	0	8	0	22
Apprch %	0	100	0	33.3	66.7	0	0	100	0	0	100	0	
Total %	0	9.1	0	13.6	27.3	0	0	13.6	0	0	36.4	0	

Lake St From North	Commonwealth Ave From East	St Thomas Moore Rd From South	Commonwealth Ave From West
13.8	447.3	447.3	447.3

36.4

13.8 447.3 183T4 3.8 447.3 466.58 3.8 447.3 646.58 462825536466.58 m 145553 183Tj ET m 74.B8 8.29 Tf362805.364658490 45536466.58 m 1473 4S 183Tj ET m 74.4 Td -8.29 T39

36.4

N/S Street : Lake St / St Thomas Moore
 E/W Street: Commonwealth Avenue
 City/State : Brighton, MA
 Weather : Clear

Accurate Counts
 978-664-2565

File Name : 390000B1
 Site Code : 39000001
 Start Date : 5/1/2008
 Page No : 1

Groups Printed- Cars

Start Time	Lake St From North			Commonwealth Ave From East			St Thomas Moore Rd From South			Commonwealth Ave From West			Int. Total
	Left	Thru	Right	Left	Thru	Right	Left	Thru	Right	Left	Thru	Right	
16:00	0	0	0	1	2	0	0	0	0	0	0	0	3
16:15	0	0	0	1	1	0	0	0	2	0	2	0	6
16:30	0	0	0	0	2	0	0	0	0	0	0	0	2
16:45	0	0	0	0	1	0	0	0	0	0	0	0	1
Total	0	0	0	2	6	0	0	0	2	0	2	0	12
17:00	0	0	0	2	0	0	0	0	0	0	3	0	5
17:15	0	0	1	2	0	0	0	0	0	0	7	0	10
17:30	0	1	0	0	1	1	0	0	1	0	0	0	4
17:45	0	1	0	1	0	0	0	0	1	1	3	1	8
Total	0	2	1	5	1	1	0	0	2	1	13	1	27
Grand Total	0	2	1	7	7	1	0	0	4	1	15	1	

Accurate Counts
978-664-2565

File Name : 390000B2
Site Code : 39000002
Start Date : 5/1/2008
Page No : 1

N/S Street : St. Thomas Moore Road
 E/W Street: Chestnut Hill Drive
 City/State : Brighton, MA
 Weather : Clear

Accurate Counts
 978-664-2565

File Name : 390000b6
 Site Code : 39000006
 Start Date : 5/1/2008
 Page No : 1

Groups Printed- Bikes

Start Time	St Thomas Moore Rd From North		Chestnut Hill Dr From East		St Thomas Moore Rd From West		Int. Total
	Left	Right	Thru	Right	Left	Thru	
16:00	0	0	0	0	0	0	0
16:15	0	0	0	0	0	0	0
16:30	0	0	0	0	0	0	0
16:45	0	0	0	0	0	0	0
Total	0	0	0	0	0	0	0
17:00	0	0	0	0	0	0	0
17:15	0	0	0	0	0	0	0
17:30	0	0	0	0	0	0	0
17:45	0	0	0	0	0	0	0
Total	0	0	0	0	0	0	0
Grand Total	0	0	0	0	0	0	0
Apprch %	0	0	0	0	0	0	
Total %							

Start Time	St Thomas Moore Rd From North			Chestnut Hill Dr From East	St Thomas Moore Rd From West
	Left	Right	App. Total		

N/S Street : Hammond Street
E/W Street: Beacon Street

Accurate Counts
978-664-2565

File Name : 390000B7
Site Code : 39000007
Start Date : 5/1/2008
Page No : 1

N/S Street : Hammond Street
 E/W Street: Beacon Street
 City/State : Newton, MA
 Weather : Clear

Accurate Counts
 978-664-2565

File Name : 390000B7
 Site Code : 39000007
 Start Date : 5/1/2008
 Page No : 1

Groups Printed- Bikes

Start Time	Hammond St From North				College Rd From Northeast				Beacon St From East				Hammond St From South				Beacon St From West			
	Hard Left	Left	Thru	Right	Hard Left	Bear Left	Bear Right	Hard Right	Left	Thru	Right	Hard Right	Left	Thru	Bear Right	Right	Left	Bear Left	Thru	Right

N/S Street : St Thomas Moore Road
E/W Street: Beacon Street
City/State : Brighton, MA
Weather : Clear

Accurate Counts
978-664-2565

File Name : 39000B15
Site Code : 39000015
Start Date : 5/1/2008
Page No : 1

Groups Printed- Bikes

Accurate Counts
978-664-2565

File Name : 39000B15
Site Code : 39000015

Accurate Counts
978-664-2565

File Name5

N/S Street : BC Main Drive
 E/W Street: Commonwealth Avenue
 City/State : Brighton, MA
 Weather : Clear

Accurate Counts
 978-664-2565

File Name : 39000B21
 Site Code : 39000021
 Start Date : 5/1/2008
 Page No : 1

Groups Printed- Bikes

Start Time	Commonwealth Ave From East		BC Main Dr From South		Commonwealth Ave From West		Int. Total
	Left	Thru	Left	Right	Thru	Right	
07:00	0	1	0	1	1	0	3
07:15	0	0	0	0	0	2	2
07:30	0	2	0	0	0	0	2
07:45	0	1	0	0	0	0	1
Total	0	4	0	1	1	2	8
08:00	0	0	0	0	0	0	0
08:15	0	2	0	0	0	0	2
08:30	0	0	0	0	1	0	1
08:45	0	1	0	0	3	0	4
Total	0	3	0	0	4	0	7
Grand Total	0	7	0	1	5	2	15
Apprch %	0	100	0	100	71.4	28.6	
Total %	0	46.7	0	6.7	33.3	13.3	

	Commonwealth Ave From East
--	-------------------------------

Accurate Counts
978-664-2565

N/S Street : St Thomas More Road
 E/W Street: BC Gate
 City/State : Brighton, MA
 Weather : Clear

Accurate Counts
 978-664-2565

File Name : 39000B24
 Site Code : 39000B24
 Start Date : 5/1/2008
 Page No : 1

Groups Printed- Bikes

Start Time	St Thomas More Rd From North		St Thomas More Rd From South			BC Gate From West		Int. Total
	Thru	Right	Left	Thru	Peds	Left	Right	
07:00	0	0	1	1	0	0	0	2
07:15	0	0	0	0	0	0	0	0
07:30	0	0	1	1	0	1	0	3
07:45	0	0	0	1	0	0	0	1
Total	0	0	2	3	0	1	0	6
08:00	0	1	0	0	0	0	1	2
08:15	0	1	0	0	0	0	0	1
08:30	0	1	1	0	0	0	1	3
08:45	0	1	0	1	0	0	0	2
Total	0	4	1	1	0	0	2	8
Grand Total	0	4	3	4	0	1	2	14
Apprch %	0	100	42.9	57.1	0	33.3	66.7	
Total %	0	28.6	21.4	28.6	0	7.1	14.3	

Start Time	St Thomas More Rd From North			St Thomas More Rd From South				BC Gate From West			Int. Total
	Thru	Right	App. Total	Left	Thru	Peds	App. Total	Left	Right	App. Total	
Peak Hour Analysis From 07:00 to 08:45 - Peak 1 of 1											
Peak Hour for Entire Intersection Begins at 08:00											
08:00	0	1	1	0	0	0	0	0	1	1	2
08:15	0	1	1	0	0	0	0	0	0	0	1
08:30	0	1	1	1	0	0	1	0	1	1	3
08:45	0	1	1	0	1	0	1	0	0	0	2
Total Volume	0	4	4	1	1	0	2	0	2	2	8

N/S Street : St Thomas More Road
E/W Street: BC Gate
City/State : Brighton, MA

Accurate Counts
978-664-2565

File Name : 39000B24
Site Code : 39000B24
Start Date : 5/1/2008
Page No : 1

N/S Street : Father Herlihy Way
E/W Street: BC Gate
City/State : Brighton, MA
Weather : Clear

Accurate Counts
978-664-2565

File Name : 39000B25
Site Code : 39000B25
Start Date : 5/1/2008
Page No : 1

Groups Printed- Bikes

Automatic Traffic Recorder (ATR) Counts

Accurate Counts
978-664-2565

Location : Commonwealth Avenue
Location : West of Lake Street
City/State: Brighton, MA
Counter : 116193

39000001
Site Code: 39000001

Start Time	11-Mar-0 Tue	WB		Hour Totals		EB		Hour Totals		Combined Totals	
		Morning	Afternoon	Morning	Afternoon	Morning	Afternoon	Morning	Afternoon	Morning	Afternoon
12:00		22	90			24	169				
12:15		19	74			26	106				
12:30		21	72			21	111				
12:45		6	91	68	327	23	131	94	517	162	844
01:00		10	77			12	132				
01:15		6	84			10	131				
01:30		6	106			12	115				
01:45		9	100	31	367	7	151	41	529	72	896
02:00		4	81			13	112				
02:15		1	110			6	119				
02:30		12	83			8	165				
02:45		2	85	19	359	5	174	32	570	51	929
03:00		4	96			3	153				
03:15		1	93			5	153				
03:30		11	87			4	194				
03:45		1	88	17	364	2	164	14	664	31	1028
04:00		5	118			3	147				
04:15		1	158			5	145				
04:30		4	122			6	160				
04:45		3	126	13	524	12	164	26	616	39	1140
05:00		1	161			6	149				
05:15		6	143			12	153				
05:30		11	122			30	180				
05:45		25	134	43	560	28	177	76	659	119	1219
06:00		18	113			35	185				
06:15		21	104			58	ref 0 0 0 rg	395.76 467.42 0.36 38	ref 0 0 0 rg	B29.30493	

1717

Accurate Counts
978-664-2565

Accurate Counts
978-664-2565

Location : Foster Street North of
Location : Rose Garden
City/State: Brighton, MA
Counter : 11660

39000004
Site Code: 39000004

Start Time	11-Mar-0 Tue	SB		Hour Totals		NB		Hour Totals		Combined Totals	
		Morning	Afternoon	Morning	Afternoon	Morning	Afternoon	Morning	Afternoon	Morning	Afternoon
12:00		10	86			2	16				
12:15		13	75			2	19				
12:30		12	66			0	22				
12:45		3	62	38	289	2	24	6	81	44	370
01:00		5	64			0	23				
01:15		1	60			2	22				
01:30		6	78			1	17				
01:45		3	81	15	283	0	14	3	76	18	359
02:00		2	95			0	20				
02:15		2	86			2	19				
02:30		1	83			1	10				
02:45		4	82	9		1	29	4	78	13	424
03:00		3	69			0	20				
03:15		0	88			1	24				
03:30		3	106			1	21				

Accurate Counts
978-664-2565

Location : Foster Street North of
Location : Rose Garden
City/State: Brighton, MA
Counter : 11660

39000004
Site Code: 39000004

Start Time	12-Mar-0 Wed	SB		Hour Totals		NB		Hour Totals		Combined Totals	
		Morning	Afternoon	Morning	Afternoon	Morning	Afternoon	Morning	Afternoon	Morning	Afternoon
12:00		17	68			4	17				
12:15		11	60			4	16				
12:30		11	78			4	25				
12:45		8	79	47	285	4	19	16	77	63	362
01:00		7	57			4	16				
01:15		6	58			0	25				
01:30		6	92			4	22				
01:45		3	80	22	287	0	14	8	77	30	364
02:00		5	74			4	27				
02:15		7	87			4	22				
02:30		4	94			2	22				
02:45		6	84	22	339	0	29	10	100	32	439
03:00		1	88			0	17				
03:15		1	95			1	18				
03:30		3	123			1	18				
03:45		0	106	5	412	0	28	2	81	7	493
04:00		2	107			1	22				
04:15		1	119			2	15				
04:30		3	123			2	21				
04:45		6	124	12	473	2	28	7	86	19	559
05:00		6	147			2	29				
05:15		2	135			2	33				
05:30		14	130			3	15				
05:45		11	149	33	561	6	16	13	93	46	654
06:00		17	130			5	27				
06:15		34	127			9	30				
06:30		39	108		92	1					
06:45		48	97								

9580 Tj ET

Accurate Counts
978-664-2565

Location : Foster Street North of
Location : Rose Garden
City/State: Brighton, MA
Counter : 11660

39000004
Site Code: 39000004

Start Time	10-Mar-08		Tue		Wed		Thu		Fri		Sat		Sun		Week Average	
	SB	NB	SB	NB	SB	NB	SB	NB	SB	NB	SB	NB	SB	NB	SB	NB
12:00 AM	*	*	38	6	47	16	*	*	*	*	*	*	*	*	42	11
01:00	*	*	15	3	22	8	*	*	*	*	*	*	*	*	18	6
02:00	*	*	9	4	22	10	*	*	*	*	*	*	*	*	16	7
03:00	*	*	8	2	5	2	*	*	*	*	*	*	*	*	6	2
04:00	*	*	10	9	12	7	*	*	*	*	*	*	*	*	11	8
05:00	*	*	40	13	33	13	*	*	*	*	*	*	*	*	36	13
06:00	*	*	150	61	138	49	*	*	*	*	*	*	*	*	144	55
07:00	*	*	366	157	354	148	*	*	*	*	*	*	*	*	360	152
08:00	*	*	483	190	505	165	*	*	*	*	*	*	*	*	494	178
09:00	*	*	358	115	348	115	*	*	*	*	*	*	*	*	353	115
10:00	*	*	258	67	235	59	*	*	*	*	*	*	*	*	246	63
11:00	*	*	253	73	277	67	*	*	*	*	*	*	*	*	265	70
12:00 PM	*	*	289	81	285	77	*	*	*	*	*	*	*	*	287	79
01:00	*	*	283	76	287	77	*	*	*	*	*	*	*	*	285	76
02:00	*	*	346	78	339	100	*	*	*	*	*	*	*	*	342	89
03:00	*	*	358	92	412	81	*	*	*	*	*	*	*	*	385	86
04:00	*	*	469	96	473	86	*	*	*	*	*	*	*	*	471	91
05:00	*	*	563	105	561	93	*	*	*	*	*	*	*	*	562	99
06:00	*	*	518	110	462	118	*	*	*	*	*	*	*	*	490	114
07:00	*	*	353	90	331	88	*	*	*	*	*	*	*	*	342	89
08:00	*	*	260	58	245	67	*	*	*	*	*	*	*	*	252	62
09:00	0.00	0.00	0.00	0.00	0.00	0.00	0.00	0.00	0.00	0.00	0.00	0.00	0.00	0.00	0.00	0.00
10:00	*	*	133	43	142	39	*	*	*	*	*	*	*	*	138	41
11:00	*	*	57	33	90	33	*	*	*	*	*	*	*	*	74	33

*7rgre f 5Td -39.8T 0.94 0 0 0 0 r502.30.36 73e f 9.36 9.34 re f BT 239.8T 0.94 0 -35

Accurate Counts
978-664-2565

Location : St Thomas Moore Way South
Location : of Commonwealth Avenue
City/State: Brighton, MA
Counter : 10110

39000005
Site Code: 39000005

Start Time	11-Mar-0 Tue	NB		Hour Totals		SB		Hour Totals		Combined Totals	
		Morning	Afternoon	Morning	Afternoon	Morning	Afternoon	Morning	Afternoon	Morning	Afternoon
12:00		8	72			4	25				
12:15		3	93			2	52				
12:30		3	77			3	34				
12:45		3	82	17	324		33	11	144	2	3
01:00		1	82			3	40				
01:15		11	67			2	28				
01:30		5	80			1	34				
01:45		4	100	21	329	2	50	8	152	2	1
02:00		2	110			1	34				
02:15		2	96			1	38				
02:30		3	97			3	45				
02:45		1	98	9	401		49	5	166	1	7
03:00		3	145			0	58				
03:15		2	115			3	55				
			84			2	3				

Location : St Thomas Moore Way South
Location : of Commonwealth Avenue
City/State: Brighton, MA
Counter : 10110

Accurate Counts
978-664-2565

39000005





















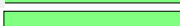
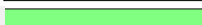

Location : St Thomas Moore Way South

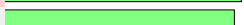
Accurate Counts
978-664-2565

Accurate Counts
978-664-2565

Location : College Road North of
Location : Beacon Street
City/State: Newton, MA
Counter : 5864

3900007
Site Code: 39000007

Start Time	Mon 10-Mar-08	Tue 11-Mar-08	Wed 12-Mar-08	Thu 13-Mar-08	Fri 14-Mar-08	Average Day	Sat 15-Mar-08	Sun 16-Mar-08	Week Average
12:00 AM	*	30	36	*	*	33	*	*	33 
01:00	*	33	36	*	*	34	*	*	34 
02:00	*	10	9	*	*	10	*	*	10 
03:00	*	11	11	*	*	11	*	*	11 
04:00	*	27	13	*	*	20	*	*	20 
05:00	*	82	34	*	*	58	*	*	58 
06:00	*	155	109	*	*	132	*	*	132 
07:00	*	230	229	*	*	230	*	*	230 
08:00	*	289	285	*	*	287	*	*	287 
09:00	*	221	211	*	*	216	*	*	216 
10:00	*	162	176	*	*	169	*	*	169 
11:00	*	187	156	*	*	172	*	*	172 
12:00 PM	*	207	184	*	*	196	*	*	196 
01:00	*	211	193	*	*	202	*	*	202 
02:00	*	251	204	*	*	228	*	*	228 
03:00	*	263	229	*	*	246	*	*	246 
04:00	*	256	280	*	*	268	*	*	268 
05:00	*	268	251	*	*	260	*	*	260 
06:00	*	255	273	*	*	264	*	*	264 
07:00	*	201	182	*	*	192	*	*	192 
08:00	*	155	169	*	*	162	*	*	162 
09:00	*	145	140	*	*	142	*	*	142 
10:00	*	94	111	*	*	102	*	*	102 
11:00	*	45	62	*	*	54	*	*	54 
Day Total	0	3788	3583	0	0	3688	0	0	3688
% Avg. WkDay	0.0%	102.7%	97.2%	0.0%	0.0%				
% Avg. Week	0.0%	102.7%	97.2%	0.0%	0.0%	100.0%	0.0%	0.0%	
AM Peak		08:00	08:00			08:00			08:00
Vol.		289	285			287			287
PM Peak		17:00	16:00			16:00			16:00
Vol.		268	280			268			268
Grand Total	0	3788	3583	0	0	3688	0	0	3688
ADT	Not Calculated								

Accurate Counts
978-664-2565

Location : Commonwealth Avenue WB West
Location : of Lake Street
City/State: Brighton, MA
Counter : 18143

Accurate Counts
978-664-2565

39000WB3
Site Code: 39000003
Daily Average

Start	Tue	11-Mar-08	Wed	12-Mar-08	Thu	13-Mar-08
-------	-----	-----------	-----	-----------	-----	-----------

Accurate Counts
978-664-2565

Location : Commonwealth Avenue WB West
Location : of Lake Street
City/State: Brighton, MA
Counter : 18143

39000WB3
Site Code: 39000003

Start Time	Mon 10-Mar-08	Tue 11-Mar-08	Wed 12-Mar-08	Thu 13-Mar-08	Fri 14-Mar-08	9090	Average Day	Sat 15-Mar-08	Sun 16-Mar-08	Week Average
12:00 AM	*	102	105	*	*		104	*	*	104
01:00	*	63	77	*	*		70	*	*	70
02:00	*	30	72	*	*		51	*	*	51
03:00	*	20	25	*	*		22	*	*	22
04:00	*	25	34	*	*		30	*	*	30
05:00	*	97	83	*	*		90	*	*	90
06:00	*	313	273	*	*		293	*	*	293
07:00	*	763	738	*	*		750	*	*	750
08:00	*	1052	1068	*	*		1060	*	*	1060
09:00	*	738	668	*	*		703	*	*	703
10:00	*	545	498	*	*		522	*	*	522
11:00	*	582	595	*	*		588	*	*	588
12:00 PM	*	557	597	*	*		577	*	*	577
01:00	*	658	619	*	*		638	*	*	638
02:00	*	714	709	*	*		712	*	*	712
03:00	*	758	787	*	*		772	*	*	772
04:00	*	920	930	*	*		925	*	*	925
05:00	*	1067	1059	*	*		1063	*	*	1063
06:00	*	990	826	*	*		908	*	*	908
07:00	*	667	606	*	*		636	*	*	636
08:00	*	465	505	*	*		485	*	*	485
09:00	*	458	435	*	*		446	*	*	446
10:00	*	270	325	*	*		298	*	*	298
11:00	*	160	180	*	*			*	*	

% Avg.06.88 233.67 9 -8.164 T 1 BT BT 6399(W22.2 508.97 Td -8.157 Ts 7 Tj ET 157 Ts Tj ET 3110 1f 0Ts (90) Tj ET .0%00) Tj ET.27 Ts 157 Ts 7 Tj ET 157 Ts Tj ET 3148 Ts 1f 0Ts (90) Tj ET 100.8%.48 327.3.2

12062.48 327.3.27 Ts 47.4 17 Tj ET 0.94 0.T 274.92 T13Ts 0.94 0 BT BT 6399(1 Td .48 327.3.27 Ts 47.4 17 Tj ET 0.94T 274.9266 -8. 47.4 1 BT BT 6399:(00) Tj ET.27 Ts 47.4 17 446) Tj ET 0 T 370.3214 Ts 47.4 1

:00
Day Total00
180

Trip Generation

4/21/2008

BC IMP Trip Generation DRAFT

Net-New Trips

	Size	Trip Rate	Less Capture	Unadjusted Vehicle Trips	VOR	Person Trips	Transit Share	Walk/Bike/Other Share	Bike Share	Vehicle Share	Local VOR	Transit Trips	Walk Trips	Bike Trips	Adjusted Vehicle Trips
AM Grad Residents		0.51										12	22	1	0
In	75	0.10		8	1.2	9	26%	48%	2%	0%	1.25	2	4	0	0
Out	beds	0.41		31	1.2	37	26%	48%	2%	0%	1.25	10	18	1	0
AM Staff/Faculty												7	16	1	93
In	350	0.29				102	6%	13%	1%	80%	1.05	6	13	1	77
Out	persons	0.06				21	6%	13%	1%	80%	1.05	1	3	0	16
AM Undergrad Beds		0.51												7	0
In	610	0.10		62	1.2	75	26%	48%	2%	0%	1.05		36	1	0
Out	beds	0.41		249	1.2	299	26%	48%	2%	0%	1.05		143	6	0
AM Graduate Commuters												24	45	2	21
In	267	0.29				77	26%	48%	2%	24%	1.05	20	37	2	18
Out	persons	0.06				16	26%	48%	2%	24%	1.05	4	8	0	4
Total AM Peak Hour												44	262	11	115
In												29	91	4	95
Out												15	171	7	20
PM Grad Residents		0.62										15	27	1	0
In	75	0.40		30	1.2	36	26%	48%	2%	0%	1.25	9	17	1	0
Out	beds	0.22		16	1.2	20	26%	48%	2%	0%	1.25	5	9	0	0
PM Staff/Faculty												9	20	2	120
In	350														



Synchro (LOS) Analysis

Table 9-37 A.M. Peak Hour LOS Summary

Signalized Intersections	Existing A.M. Peak Hour				No Build A.M. Peak Hour				Build A.M. Peak Hour			
	LOS	Delay (sec/veh)	Max V/C Ratio*	Max 95 th % Queue (ft)*	LOS	Delay (sec/veh)	Max V/C Ratio*	Max 95 th % Queue (ft)*	LOS	Delay (sec/veh)	Max V/C Ratio*	Max 95 th % Queue (ft)*
Commonwealth Ave at Lake St/ St. Thomas More Rd	E	68.0	0.83		F	>80.0			F	>80.0	0.94	
EB Commonwealth Ave	C	22.6	0.67	248	C	23.2	0.71	#271	C	25.7	0.80	#340
WB Commonwealth Ave	F	>80.0	>1.0	#316	F	>80.0	>1.0	#339	F	>80.0	>1.0	#387
NB St. T More Rd	F	>80.0	>1.0	#162	F	>80.0	>1.0	#176	F	>80.0	>1.0	#213
Commonwealth Ave at Chestnut Hill Ave	F	>80.0	>1.0		F	>80.0			F	>80.0		

Table 9-37 A.M. Peak Hour LOS Summary (Continued)

Signalized Intersections	Existing A.M. Peak Hour			No Build A.M. Peak Hour		Build A.M. Peak Hour	
	LOS	Delay (sec/veh)	Max V/C Ratio*	Max 95 th % Queue (ft)*	LOS		

Table 9-38 P.M. Peak Hour LOS Summary

Signalized Intersections	Existing P.M. Peak Hour				No Build P.M. Peak Hour				Build P.M. Peak Hour			
	LOS	Delay (sec/veh)	Max V/C Ratio*	Max 95 th % Queue (ft)*	LOS	Delay (sec/veh)	Max V/C Ratio*	Max 95 th % Queue (ft)*	LOS	Delay (sec/veh)	Max V/C Ratio*	Max 95 th % Queue (ft)*
Commonwealth Ave at Lake St/St. Thomas More Rd ft0 ft0	E	77.3	0.91		F	>80.0			F	>80.0	>1.0	

Table 9-38 P.M. Peak Hour LOS Summary (Continued)

Signalized Intersections	Existing P.M. Peak Hour				No Build P.M. Peak Hour				Build P.M. Peak Hour			
	LOS	Delay (sec/veh)	Max V/C Ratio*	Max 95 th % Queue (ft)*	LOS	Delay (sec/veh)	Max V/C Ratio*	Max 95 th % Queue (ft)*	LOS	Delay (sec/veh)	Max V/C Ratio*	Max 95 th % Queue (ft)*
Washington St at Lake St/ Brook St	D	40.7	0.92		F	>80.0			F	>80.0	>1.0	
EB Washington St	C	27.3	0.85	#681	F	>80.0	>1.0	#837	F	>80.0	>1.0	#889
WB Washington St	B	15.6	0.62	389	D	53.8	0.89	m#435	E	61.9	0.92	m#402
NB Lake St	F	>80.0	>1.00	#590	C	25.4	0.72	#569	C	27.2	0.78	#659
Foster St at Washington St	C	26.0	0.89		E	69.9			F	>80.0	0.93	
EB Washington St	B	19.7	0.83	#419	F	>80.0	>1.0	m144	F	>80.0	>1.0	m137
WB Washington St	C	32.7	>1.00	212	C	28.6	0.80	m214	D	36.6	0.83	m220
NB Foster Street	C	26.3	0.39	#97	D	39.2	0.56	#119	D	47.1	0.55	#136
SB Foster St	C	24.5	0.67	140	D	50.0	0.79	220	D	47.9	0.79	222
Washington St/Chestnut Hill Avenue /Market St	F	>80.0	>1.0		F	>80.00			F	>80.0	>1.0	
EB Washington St	F	>80.0	>1.0	#1094	F	>80.0	>1.0	#827	F	>80.0	>1.0	#875
WB Washington St	F	>80.0	>1.0	#817	F	>80.0	>1.0	#873	F	>80.0	>1.0	#898
NB Chestnut Hill Ave	C	27.5	0.59	244	C	25.4	0.56	255	C	24.5	0.55	251
SB Market St	D	38.1	0.84	#419	C	34.8	0.70	#453	C	32.8	0.82	#460
Unsignalized Intersections Commonwealth Ave at Foster St												
SB Foster St	C	22.2	0.67	125	D	25.1	0.72	148	D	27.6	0.75	165
Commonwealth Ave at Old Colony/College Rd												
NB C TD5.1m> 1	47.1	Tc(Common4.9398	3.4962	TD.0014	Tc(NB C TD5.1m>)	T4C5175ck014	Tc()92()5B0e18	Tc3e227	436	E458(1)-98)4030.199	.1t HB0e

Table 9-38 P.M. Peak Hour LOS Summary (Continued)

Signalized Intersections	Existing P.M. Peak Hour				No Build P.M. Peak Hour				Build P.M. Peak Hour			
	LOS	Delay (sec/veh)	Max V/C Ratio*	Max 95 th % Queue (ft)*	LOS	Delay (sec/veh)	Max V/C Ratio*	Max 95 th % Queue (ft)*	LOS	Delay (sec/veh)	Max V/C Ratio*	Max 95 th % Queue (ft)*
St. Thomas More Rd at Campanella Way EB Fr. Herlihy Dr	B	14.3	0.24	23	B	15.0	0.26	26	C	17.2	0.30	32
Fr Herilihy Dr at Campanella Way SB Fr Herilihy Dr	A	7.7	0.13	n/a	A	8.9	0.24	n/a	A	9.7	0.32	n/a
St. Thomas More Rd at Chestnut Hill Driveway WB Chestnut Hill Driveway	E	36.6	0.45	53	E	44.6	0.54	70	F	>50.0	0.58	78
Lake St at Kenrick St EB Kenrick St	E	43.6	0.62	91	F	>50.0	0.70	112	F	>50.0	0.75	125
Lake St at Glenmont Rd WB Glenmont Rd	C	18.7	0.34	37	C	19.8	0.37	41	C	21.5	0.40	46
Foster St at Rogers Park Ave EB Rogers Park Ave	C	19.7	0.42	51	C	22.7	0.48	62	D	33.1	0.60	91
Beacon St/Beacon Garage SB Driveway	F	>50.0	>1.0	604	F	>50.0	>1.0	692	F	>50.0	>1.0	1078

Existing 2008

Queues

2: Commonwealth Ave & Lake Street

6/3/2008

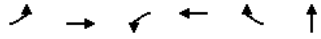

Lane Group	EBL	EBT	WBL	WBT	WBR	NBT
Lane Group Flow (vph)	320	631	284	622	108	379
w/c Ratio	0.68	0.45	1.09	1.11	0.34	1.04
Control Delay	34.5	17.9	117.8	106.7	10.1	90.4
Queue Delay	0.0	0.0	0.0	0.0	0.0	0.0
Total Delay	34.5	17.9	117.8	106.7	10.1	90.4
Queue Length 50th (ft)	149	120	~174	~203	0	~110
Queue Length 95th (ft)	248	158	#310	#316	38	#162

HCM Signalized Intersection Capacity Analysis
2: Commonwealth Ave & Lake Street

6/3/2008



Movement	SBR
Lane Configurations	
Ideal Flow (vphpl)	1900
Lane Width	12
Total Lost time (s)	
Lane Util. Factor	
Frpb, ped/bikes	
Fipb, ped/bikes	
Frt	
Flt Protected	
Satd. Flow (prot)	
Flt Permitted	
Satd. Flow (perm)	
Volume (vph)	0
Peak-hour factor, PHF	0.25
Adj. Flow (vph)	0
RTOR Reduction (vph)	0
Lane Group Flow (vph)	0
Confl. Peds. (#/hr)	
Heavy Vehicles (%)	0%
Turn Type	
Protected Phases	
Permitted Phases	
Actuated Green, G (s)	
Effective Green, g (s)	
Actuated g/C Ratio	
Clearance Time (s)	
Vehicle Extension (s)	
Lane Grp Cap (vph)	
v/s Ratio Prot	
v/s Ratio Perm	
v/c Ratio	
Uniform Delay, d1	
Progression Factor	
Incremental Delay, d2	
Delay (s)	
Level of Service	
Approach Delay (s)	
Approach LOS	
Intersection Summary	

Queues
3: Commonwealth Ave & Chestnut Hill

6/3/2008

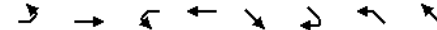

Lane Group	EBL	EBT	WBL	WBT	SET	SER	NWL	NWT
Lane Group Flow (vph)	163	717	215	341	540	57	172	850
v/c Ratio	0.47	0.95	0.82	0.52	1.41	0.16	0.60	1.36
Control Delay	28.5	62.2	40.8	43.4	234.7	24.4	68.3	208.3
Queue Delay	0.0	0.0	0.0	0.0	0.0	0.0	0.0	0.0
Total Delay	28.5	62.2	40.8	43.4	234.7	24.4	68.3	208.3
Queue Length 50th (ft)	85	257	116	119	-295	20	137	-864
Queue Length 95th (ft)	100	#346	#211	175	#409	38	m106	m478
Internal Link Dist (ft)		1348		1135	4158			919
Turn Bay Length (ft)	200		100			50		
Base Capacity (vph)	394	757	311	658	383	356	288	627
Starvation Cap Reductn	0	0	0	0	0	0	0	0
Spillback Cap Reductn	0	0	0	0	0	0	0	0
Storage Cap Reductn	0	0	0	0	0	0	0	0
Reduced v/c Ratio	0.41	0.95	0.69	0.52	1.41	0.16	0.60	1.36

Intersection Summary
~ Volume exceeds capacity, queue is theoretically infinite. Queue shown is maximum after two cycles.
95th percentile volume exceeds capacity, queue may be longer. Queue shown is maximum after two cycles.
m Volume for 95th percentile queue is metered by upstream signal.

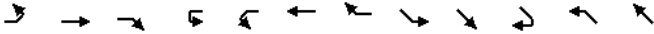

Queues

7: Beacon St & Chestnut Hill Ave

6/3/2008

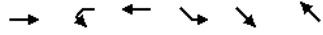

Lane Group	EBT	WBL	WBT	SEL	SET	NWT
Lane Group Flow (vph)	726nWT					

HCM Unsignalized Intersection Capacity Analysis

8: Beacon St & Gate House Road

6/3/2008



HCM Signalized Intersection Capacity Analysis

13: Washington St & Chestnut Hill

6/3/2008



Movement	EBL	EBT	EBR	WBL	WBT	WBR	NBL	NBT	NBR	SBL	SBT	SBR
Lane Configurations	↔ ↗ ↘ ↙ ↘ ↗ ↖ ↗ ↘ ↙ ↘ ↗ ↖											
Ideal Flow (vphpl)	1900	1900	1900	1900	1900	1900	1900	1900	1900	1900	1900	1900
Lane Width	10	11	16	10	11	16	16	16	16	12	12	10
Total Lost time (s)	4.0			4.0			4.0			4.0		
Lane Util. Factor	1.00			1.00			1.00			1.00		
Frt	0.98			1.00			0.98			1.00		
Flt Protected	0.99			0.95			1.00			0.95		
Satd. Flow (prot)	1369			1189			1218			1841		
Flt Permitted	0.25			0.16			1.00			0.42		
Satd. Flow (perm)	342			205			1218			908		
Volume (vph)	55	412	97	32	322	127	61	335	42	76	320	84
Peak-hour factor, PHF	0.86	0.96	0.89	0.61	0.88	0.81	0.78	0.99	0.71	0.67	0.94	0.76
Adj. Flow (vph)	64	429	109	52	366	157	78	338	59	113	340	111
RTOR Reduction (vph)	0	0	0	0	0	0	0	0	0	0	0	0
Lane Group Flow (vph)	0	602	0	52	523	0	78	397	0	113	340	111
Heavy Vehicles (%)	2%	3%	1%	0%	1%	3%	0%	2%	0%	5%	1%	4%
Bus Blockages (#/hr)	0	0	0	26	26	26	0	0	0	0	0	0
Parking (#/hr)	5	5	5	5	5	5				5	5	5
Turn Type	Perm			Perm			Perm			Perm		
Protected Phases	1			1			3			3		
Permitted Phases	1			1			3			3		
Actuated Green, G (s)	25.2			25.2			43.4			43.4		
Effective Green, g (s)	25.2			25.2			43.4			43.4		
Actuated g/C Ratio	0.28			0.28			0.48			0.48		
Clearance Time (s)	4.0			4.0			4.0			4.0		
Vehicle Extension (s)	3.0			3.0			3.0			3.0		
Lane Grp Cap (vph)	96			57			341			438		
v/s Ratio Prot				0.43			0.21			c0.23		
v/s Ratio Perm	c1.76			0.25			0.09			0.19		
v/c Ratio	6.27			0.91			1.53			0.18		
Uniform Delay, d1	32.4			31.3			32.4			13.2		
Progression Factor	1.00			1.00			1.00			1.00		
Incremental Delay, d2	2394.0			95.8			254.5			0.2		
Delay (s)	2426.4			127.2			286.9			13.4		
Level of Service	F			F			B			B		
Approach Delay (s)	2426.4			272.4			15.3			15.6		
Approach LOS	F			F			B			B		

Intersection Summary			
HCM Average Control Delay	737.1	HCM Level of Service	F
HCM Volume to Capacity ratio	2.61		
Actuated Cycle Length (s)	90.0	Sum of lost time (s)	21.4
Intersection Capacity Utilization	101.9%	ICU Level of Service	G
Analysis Period (min)	15		
c Critical Lane Group			

HCM Unsignalized Intersection Capacity Analysis

15: Campanella Way & St. T Moore

6/3/2008



Movement	EBL	EBR	NBL	NBT	SBT	SBR
Lane Configurations	↖ ↗ ↘ ↙ ↘ ↗					
Sign Control	Yield		Free		Free	
Grade	0%		0%		0%	
Volume (veh/h)	23	63	105	255	120	121
Peak Hour Factor	0.69	0.70	0.51	0.88	0.72	0.81
Hourly flow rate (vph)	33	90	206	290	167	149
Pedestrians						
Lane Width (ft)						
Walking Speed (ft/s)						
Percent Blockage						
Right turn flare (veh)						
Median type	None					
Median storage (veh)						
Upstream signal (ft)	366					
pX, platoon unblocked						
vC, conflicting volume	943	241	316			
vC1, stage 1 conf vol						
vC2, stage 2 conf vol						
vCu, unblocked vol	943	241	316			
tC, single (s)	6.9	6.2	4.2			
tC, 2 stage (s)						
tF (s)	3.9	3.3	2.3			
p0 queue free %	83	89	82			
cM capacity (veh/h)	200	800	1174			

Direction, Lane #	EB 1	NB 1	SB 1
Volume Total	123	496	316
Volume Left	33	206	0
Volume Right	90	0	149
cSH	441	1174	1700
Volume to Capacity	0.28	0.18	0.19
Queue Length 95th (ft)	28	16	0
Control Delay (s)	16.3	4.7	0.0
Lane LOS	C	A	
Approach Delay (s)	16.3	4.7	0.0
Approach LOS	C		

Intersection Summary			
Average Delay	4.6		
Intersection Capacity Utilization	52.3%	ICU Level of Service	A
Analysis Period (min)	15		

Queues

16: Washington St & Brock St

6/3/2008



Lane Group	EBT	WBT	NBT
------------	-----	-----	-----

Queues

18: Commonwealth Ave & South St

6/3/2008



Lane Group	EBT	WBT	SWL
Lane Group Flow (vph)	714	526	212
w/c Ratio	0.43	0.32	0.39
Control Delay	12.5	11.4	7.1
Queue Delay	0.0	0.0	0.0

HCM Unsignalized Intersection Capacity Analysis

19: Commonwealth Ave & Foster St

6/3/2008

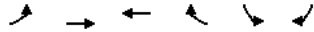

Movement	EBL	EBT	WBT	WBR	SBL	SBR
Lane Configurations		↑↑	↑↑			↘
Sign Control		Free	Free		Stop	
Grade		0%	0%		0%	
Volume (veh/h)	0	616	613	80	0	351
Peak Hour Factor	0.25	0.89	0.96	0.77	0.25	0.90
Hourly flow rate (vph)	0	692	639	104	0	390
Pedestrians		59			59	
Lane Width (ft)		12.0			12.0	
Walking Speed (ft/s)		4.0			4.0	
Percent Blockage		5			5	
Right turn flare (veh)						
Median type					None	
Median storage (veh)						
Upstream signal (ft)			504			
pX, platoon unblocked	0.94				0.94	0.94
vC, conflicting volume	801				1096	489
vC1, stage 1 conf vol						
vC2, stage 2 conf vol						
vCu, unblocked vol	724				1037	392
tC, single (s)	4.1				6.8	6.9
tC, 2 stage (s)						
tF (s)	2.2				3.5	3.3
p0 queue free %	100				100	25
cM capacity (veh/h)	793				206	518
Direction, Lane #	EB 1	EB 2	WB 1	WB 2	SB 1	



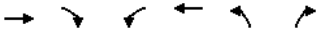



↗ → ↘ ↙ ←

HCM Unsignalized Intersection Capacity Analysis

46: Chestnut Hill Driveway & T. Moore

6/3/2008



Movement	WBL	WBR	NBT	NBR	SBL	SBT
Lane Configurations	WT		BT			BT
Sign Control	Stop		Free		Free	
Grade	0%		0%		0%	
Volume (veh/h)	55	8	312	148	4	200
Peak Hour Factor	0.69	0.70	0.51	0.88	0.69	0.70
Hourly flow rate (vph)	80	11	612	168	6	286
Pedestrians						
Lane Width (ft)						
Walking Speed (ft/s)						
Percent Blockage						
Right turn flare (veh)						
Median type	None					
Median storage (veh)						
Upstream signal (ft)						
pX, platoon unblocked						

HCM Unsignalized Intersection Capacity Analysis

51: Campanella Way & Fr. Herlihy Drive

6/3/2008

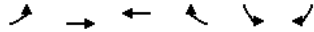

Movement	EBL	EBT	WBT	WBR	SBL	SBR
Lane Configurations		↑	↑		↓	↓
Sign Control		Stop	Yield		Stop	
Volume (vph)	0	15	226	0	71	169
Peak Hour Factor	0.25	0.71	0.70	0.25	0.89	0.83
Hourly flow rate (vph)	0	21	323	0	80	204
Direction, Lane #	EB 1	WB 1	SB 1	SB 2		
Volume Total (vph)	21	323	80	204		
Volume Left (vph)	0	0	80	0		
Volume Right (vph)	0	0	0	204		
Hadj (s)	0.00	0.05	0.72	-0.65		
Departure Headway (s)	5.0	4.7	6.1	4.7		
Degree Utilization, x	0.03	0.42	0.13	0.27		
Capacity (veh/h)	663	739	566	726		
Control Delay (s)	8.2	11.0	8.8	8.2		
Approach Delay (s)	8.2	11.0	8.4			
Approach LOS	A	B	A			
Intersection Summary						
Delay	9.7					
HCM Level of Service	A					
Intersection Capacity Utilization	31.6%		ICU Level of Service	A		
Analysis Period (min)	15					

Queues
2: Commonwealth Ave & Lake Street

6/3/2008



Lane Group	EBL	EBT	EBR	WBL	WBT	WBR	NBL	NBT	NBR	SBL	SBT

Queue Length 50th (ft)	110	177	148	222	0	-257					
Internal Link Dist (ft)		1877		667		202					
Base Capacity (vph)	324	1247	459	976	437	424					
Spillback Cap Reductn	0	0	0	0	0	0					
Storage Cap Reductn	0	0	0	0	0	0					
Reduced v/c Ratio	0.58	0.51	0.60	0.76	0.30	1.37					

Intersection Summary

~ Volume exceeds capacity, queue is theoretically infinite.
Queue shown is maximum after two cycles.

95th percentile volume exceeds capacity, queue may be longer.
Queue shown is maximum after two cycles.

HCM Signalized Intersection Capacity Analysis
2: Commonwealth Ave & Lake Street

6/3/2008

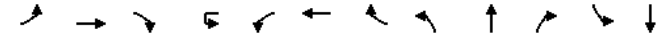

Movement	EBL	EBT	EBR	WBL	WBT	WBR	NBL	NBT	NBR	SBL	SBT
Lane Configurations											
Ideal Flow (vphpl)	1900	1900	1900	1900	1900	1900	1900	1000	1900	1900	1900
Lane Width	11	12	12	12	11	12	12	10	10	10	12
Total Lost time (s)	4.0	4.0			4.0	4.0	4.0		4.0		
Lane Util. Factor	1.00	0.95			1.00	0.95	1.00		0.95		
Flt Protected	0.95	1.00			0.95	1.00	1.00		0.98		
Satd. Flow (prot)	1570	3177			1528	3249	1179		1521		
Flt Permitted	0.95	1.00			0.95	1.00	1.00		0.98		
Satd. Flow (perm)	1570	3177			1528	3249	1179		1521		
Volume (vph)	164	494	7	19	212	674	115	158	243	78	0
Peak-hour factor, PHF	0.87	0.80	0.58	0.92	0.83	0.91	0.87	0.84	0.84	0.75	0.25
Adj. Flow (vph)	189	618	12	21	255	741	132	188	289	104	0
RTOR Reduction (vph)	0	1	0	0	0	0	95	0	16	0	0
Lane Group Flow (vph)	189	629	0	0	276	741	37	0	565	0	0
Confl. Peds. (#/hr)							54				
Heavy Vehicles (%)	0%	2%	0%	0%	3%	0%	1%	1%	0%	1%	0%
Turn Type	Prot			Split	Split	Perm	Split				
Protected Phases	1	2		3	3	3	4	4			
Permitted Phases						3					
Actuated Green, G (s)	20.1	32.0			27.1	27.1	27.1		26.1		
Effective Green, g (s)	20.1	32.0			27.1	27.1	27.1		26.1		
Actuated g/C Ratio	0.21	0.33			0.28	0.28	0.28		0.27		
Clearance Time (s)	4.0				4.0	4.0	4.0		4.0		
Vehicle Extension (s)	3.0				3.0	3.0	3.0		3.0		
Lane Grp Cap (vph)	325	1046			426	906	329		408		
v/s Ratio Prot	0.12	c0.20			0.18	c0.23			c0.37		
v/s Ratio Perm							0.03				

51G.wv7/1

HCM Signalized Intersection Capacity Analysis

2: Commonwealth Ave & Lake Street

6/3/2008



























Movement	SBR
Lane Configurations	
Ideal Flow (vphpl)	1900
Lane Width	12
Total Lost time (s)	
Lane Util. Factor	
Frbp, ped/bikes	
Fipb, ped/bikes	
Frt	
Flt Protected	
Satd. Flow (prot)	
Flt Permitted	
Satd. Flow (perm)	
Volume (vph)	0
Peak-hour factor, PHF	0.25
Adj. Flow (vph)	0
RTOR Reduction (vph)	0
Lane Group Flow (vph)	0
Confl. Peds. (#/hr)	

HCM Signalized Intersection Capacity Analysis

3: Commonwealth Ave & Chestnut Hill

6/3/2008

													
Movement	EBL	EBT	EBR	WBU	WBL	WBT	WBR	SEL	SET	SER	NWL	NWT	
Lane Configurations													

Queues

7: Beacon St & Chestnut Hill Ave

6/3/2008

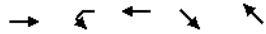

Lane Group	EBT	WBL	WBT	SET	NWT
Lane Group Flow (vph)	654	192	781	937	719
v/c Ratio	1.89	1.32	0.57	0.59	0.92
Control Delay	440.6	214.6	39.8	23.4	40.8
Queue Delay	0.0	0.0	0.0	0.0	0.0
Total Delay	440.6	214.6	39.8	23.4	40.8
Queue Length 50th (ft)	~443	~162	202	189	307
Queue Length 95th (ft)	#494	#255	248	229	#427
Internal Link Dist (ft)	3431		1419	919	239
Turn Bay Length (ft)		100			
Base Capacity (vph)	346	146	1368	1597	785
Starvation Cap Reductn	0	0	0	0	0
Spillback Cap Reductn	0	0	0	0	0
Storage Cap Reductn	0	0	0	0	0
Reduced v/c Ratio	1.89	1.32	0.57	0.59	0.92

Intersection Summary

~ Volume exceeds capacity, queue is theoretically infinite.

Queue shown is maximum after two cycles.

95th percentile volume exceeds capacity, queue may be longer.

Queue shown is maximum after two cycles.

HCM Signalized Intersection Capacity Analysis

7: Beacon St & Chestnut Hill Ave

6/3/2008

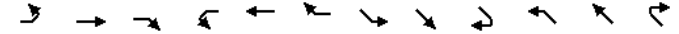

Movement	EBL	EBT	EBR	WBL	WBT	WBR	SEL	SET	SER	NWL	NWT	NWR
Lane Configurations		↕↕		↕	↕↕↕			↕↕↕				↕↕
Ideal Flow (vphpl)	1900	1900	1900	1900	1900	1900	1900	1900	1900	1900	1900	1900
Lane Width	11	11	11	11	12	12	10	11	10	14	16	16
Total Lost time (s)		4.0		4.0	4.0			4.0				4.0
Lane Util. Factor		0.95		1.00	0.91			0.91				0.95
Frt		0.98		1.00	0.96			0.98				0.98
Flt Protected		0.99		0.95	1.00			0.99				1.00
Satd. Flow (prot)		3055		1555	4447			4246				3470
Flt Permitted		0.52		0.15	1.00			0.66				0.75
Satd. Flow (perm)		1612		241	4447			2816				2618
Volume (vph)	69	394	76	150	505	213	162	565	98	53	496	88
Peak-hour factor, PHF	0.86	0.81	0.86	0.78	0.92	0.92	0.77	0.92	0.87	0.83	0.90	0.85
Adj. Flow (vph)	80	486	88	192	549	232	210	614	113	64	551	104
RTOR Reduction (vph)	0	0	0	0	0	0	0	0	0	0	0	0
Lane Group Flow (vph)	0	654	0	192	781	0	0	937	0	0	719	0
Heavy Vehicles (%)	1%	0%	0%	1%	0%	1%	1%	4%	3%	2%	3%	6%
Turn Type	Perm			D,P+P			D,P+P				Perm	
Protected Phases		1		11	1		8	8	9			9
Permitted Phases	1			1			9				9	
Actuated Green, G (s)		27.2		35.2	39.2			64.0				39.0
Effective Green, g (s)		27.2		35.2	39.2			62.0				39.0
Actuated g/C Ratio		0.21		0.27	0.30			0.48				0.30
Clearance Time (s)		4.0		4.0								4.0
Vehicle Extension (s)		3.0		3.0								3.0
Lane Grp Cap (vph)		337		146	1341			1596				785
v/s Ratio Prot				c0.08	0.18			c0.10				
v/s Ratio Perm		c0.41		0.28				0.18				c0.27
v/c Ratio		1.94		1.32	0.58			0.59				0.92
Uniform Delay, d1		51.4		43.4	38.5			24.7				43.9
Progression Factor		1.00		1.00	1.00			1.00				0.53
Incremental Delay, d2		434.0		181.9	0.6			1.6				16.2
Delay (s)		485.4		225.3	39.1			26.3				39.6
Level of Service		F		F	D			C				D
Approach Delay (s)		485.4			75.8			26.3				39.6
Approach LOS		F			E			C				D

Intersection Summary

HCM Average Control Delay	135.4	HCM Level of Service	F
HCM Volume to Capacity ratio	1.16		
Actuated Cycle Length (s)	130.0	Sum of lost time (s)	32.8
Intersection Capacity Utilization	84.8%	ICU Level of Service	E
Analysis Period (min)	15		
c Critical Lane Group			



Queues

16: Washington St & Brock St

6/3/2008



Lane Group	EBT	WBT	NBT
------------	-----	-----	-----

Queues

18: Commonwealth Ave & South St

6/3/2008

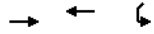

Lane Group	EBT	WBT	SWL
Lane Group Flow (vph)	755	634	208
v/c Ratio	0.45	0.38	0.39
Control Delay	12.7	11.9	8.1
Queue Delay	0.0	0.0	0.0
Total Delay	12.7	11.9	8.1
Queue Length 50th (ft)	82	66	9
Queue Length 95th (ft)	187	164	43
Internal Link Dist (ft)	424	1348	723
Turn Bay Length (ft)			
Base Capacity (vph)	1669	1669	538
Starvation Cap Reductn	0	0	0
Spillback Cap Reductn	0	0	0
Storage Cap Reductn	0	0	0
Reduced v/c Ratio	0.45	0.38	0.39

Intersection Summary

HCM Signalized Intersection Capacity Analysis

18: Commonwealth Ave & South St

6/3/2008

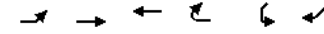

Movement	EBL	EBT	WBT	WBR	SWL	SWR
Lane Configurations		↑↑	↑↑		↑↑	↑↑
Ideal Flow (vphpl)	1900	1900	1900	1900	1900	1900
Total Lost time (s)		4.0	4.0		4.0	
Lane Util. Factor		0.95	0.95		1.00	
Frt		1.00	1.00		0.89	
Flt Protected		1.00	1.00		0.99	
Satd. Flow (prot)		3249	3249		1329	
Flt Permitted		1.00	1.00		0.99	
Satd. Flow (perm)		3249	3249		1329	
Volume (vph)	0	627	552	0	27	153
Peak-hour factor, PHF	0.25	0.83	0.87	0.25	0.75	0.89
Adj. Flow (vph)	0	755	634	0	36	172
RTOR Reduction (vph)	0	0	0	0	120	0
Lane Group Flow (vph)	0	755	634	0	88	0
Heavy Vehicles (%)	0%	0%	0%	0%	0%	1%
Parking (#/hr)					2	2
Turn Type						
Protected Phases		1	1		3	
Permitted Phases						
Actuated Green, G (s)		34.4	34.4		21.3	
Effective Green, g (s)		34.4	34.4		21.3	
Actuated g/C Ratio		0.49	0.49		0.30	
Clearance Time (s)		4.0	4.0		4.0	
Vehicle Extension (s)		3.0	3.0		3.0	
Lane Grp Cap (vph)		1590	1590		403	
v/s Ratio Prot		c0.23	c0.20		c0.07	
v/s Ratio Perm						
v/c Ratio		0.47	0.40		0.22	
Uniform Delay, d1		11.9	11.4		18.3	
Progression Factor		1.00	1.00		1.00	
Incremental Delay, d2		1.0	0.7		1.2	
Delay (s)		13.0	12.1		19.5	
Level of Service		B	B		B	
Approach Delay (s)		13.0	12.1		19.5	
Approach LOS		B	B		B	
Intersection Summary						
HCM Average Control Delay		13.5		HCM Level of Service		B
HCM Volume to Capacity ratio		0.38				
Actuated Cycle Length (s)		70.3		Sum of lost time (s)		14.6
Intersection Capacity Utilization		38.1%		ICU Level of Service		A
Analysis Period (min)		15				
c Critical Lane Group						

HCM Unsignalized Intersection Capacity Analysis

19: Commonwealth Ave & Foster St

6/3/2008



Movement	EBL	EBT	WBT	WBR	SBL	SBR
Lane Configurations		↑↑	↑↑			↑
Sign Control		Free	Free		Stop	
Grade		0%	0%		0%	
Volume (veh/h)	0	618	666	50	0	357
Peak Hour Factor	0.25	0.83	0.94	0.74	0.25	0.89

HCM Signalized Intersection Capacity Analysis

20: Washington St & Foster St

6/3/2008



Movement	EBL	EBT	EBR	WBL	WBT	WBR	NBL	NBT	NBR	SBL	SBT	SBR
Lane Configurations		↔		↔	↕		↔		↕		↔	↕
Ideal Flow (vphpl)	1900	1900	1900	1900	1900	1900	1900	1900	1900	1900	1900	1900
Lane Width	12	12	10	10	12	12	10	10	10	12	10	10
Total Lost time (s)		4.0		4.0	4.0		4.0		4.0		4.0	
Lane Util. Factor		1.00		1.00	1.00		1.00		1.00		1.00	
Frt		0.97		1.00	1.00		1.00		0.85		0.98	
Flt Protected		1.00		0.95	1.00		0.95		1.00		0.99	
Satd. Flow (prot)		1590		1501	1605		1486		1184		1541	
Flt Permitted		1.00		0.23	1.00		0.50		1.00		0.99	
Satd. Flow (perm)		1590		356	1605		785		1184		1541	
Volume (vph)	0	432	142	220	400	0	68	0	130	42	133	37
Peak-hour factor, PHF	0.25	0.86	0.87	0.87	0.94	0.25	0.90	0.25	0.88	0.70	0.88	0.84

HCM Unsignalized Intersection Capacity Analysis

26: Commonwealth Ave & Campus Driveway

6/3/2008

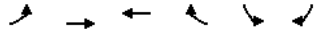

Movement	EBL	EBT	WBT	WBR	SBL	SBR
Lane Configurations		↑↑	↑↑			↑
Sign Control	Free	Free	Free	Free	Stop	Stop
Grade	0%	0%	0%	0%	0%	0%
Volume (veh/h)	0	601	953	3	0	57
Peak Hour Factor	0.25	0.83	0.93	0.75	0.25	0.89
Hourly flow rate (vph)	0	724	1025	4	0	64
Pedestrians		101			101	
Lane Width (ft)		12.0			12.0	
Walking Speed (ft/s)		4.0			4.0	
Percent Blockage		8			8	
Right turn flare (veh)						
Median type					None	
Median storage (veh)						
Upstream signal (ft)		747				
pX, platoon unblocked					0.87	
vC, conflicting volume	1130				1490	716
vC1, stage 1 conf vol						
vC2, stage 2 conf vol						
vCu, unblocked vol	1130				1416	716
tC, single (s)	4.1				6.8	6.9
tC, 2 stage (s)						
tF (s)	2.2				3.5	3.3
p0 queue free %	100				100	80
cM capacity (veh/h)	573				104	316
Direction, Lane #	EB 1	EB 2	WB 1	WB 2	SB 1	
Volume Total	362	362	683	346	64	
Volume Left	0	0	0	0	0	

HCM Unsignalized Intersection Capacity Analysis

33: Beacon St & Reservoir Rd

6/3/2008

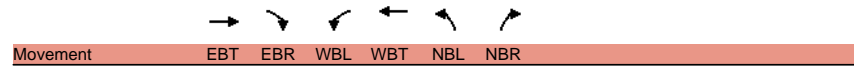

HCM Signalized Intersection Capacity Analysis

35: Beacon St & College Rd

6/3/2008



HCM Unsignalized Intersection Capacity Analysis

38: Commonwealth Ave & Mt Alvernia Road

6/3/2008

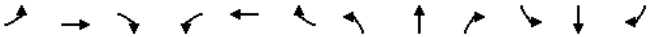

HCM Unsignalized Intersection Capacity Analysis

46: Chestnut Hill Driveway & T. Moore

6/3/2008



Movement	WBL	WBR	NBT	NBR	SBL	SBT
Lane Configurations	↔	↔	↕	↕	↔	↔
Sign Control	Stop		Free			Free
Grade	0%		0%			0%
Volume (veh/h)	50	13	230	83	37	368
Peak Hour Factor	0.69	0.70	0.51	0.88	0.69	0.70
Hourly flow rate (vph)	72	19	451	94	54	526
Pedestrians						
Lane Width (ft)						
Walking Speed (ft/s)						
Percent Blockage						
Right turn flare (veh)						
Median type	None					
Median storage (veh)						
Upstream signal (ft)						
pX, platoon unblocked						
vC, conflicting volume	1131	498			545	
vC1, stage 1 conf vol						
vC2, stage 2 conf vol						
vCu, unblocked vol	1131	498			545	
tC, single (s)	6.9	6.2			4.2	
tC, 2 stage (s)						
tF (s)	3.9	3.3			2.3	
p0 queue free %	58	97			94	
cM capacity (veh/h)	173	574			962	
Direction, Lane #	WB 1	NB 1	SB 1			
Volume Total	91	545	579			
Volume Left	72	0	54			
Volume Right	19	94	0			
cSH	202	1700	962			
Volume to Capacity	0.45	0.32	0.06			
Queue Length 95th (ft)	53	0	4			
Control Delay (s)	36.6	0.0	1.5			
Lane LOS	E		A			
Approach Delay (s)	36.6	0.0	1.5			
Approach LOS	E					
Intersection Summary						
Average Delay	3.5					
Intersection Capacity Utilization	56.8%			ICU Level of Service	B	
Analysis Period (min)	15					

HCM Unsignalized Intersection Capacity Analysis

49: Beacon St Garage &

6/3/2008

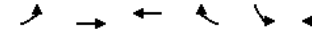

Movement	EBL	EBT	WBT	WBR	SBL	SBR
Lane Configurations	↔	↔	↕	↕	↔	↔
Sign Control	Free	Free	Free		Stop	↔
Grade	0%	0%			0%	
Volume (veh/h)	25	656	927	22	49	96
Peak Hour Factor	0.78	0.88	0.93	0.79	0.64	0.25
Hourly flow rate (vph)	32	745	997	28	77	384
Pedestrians		50	47		42	
Lane Width (ft)	14.0	14.0			12.0	
Walking Speed (ft/s)	4.0	4.0			4.0	
Percent Blockage	5	5			4	
Right turn flare (veh)						
Median type	None					
Median storage (veh)						
Upstream signal (ft)						
pX, platoon unblocked						
vC, conflicting volume	1067				1909	1103
vC1, stage 1 conf vol						
vC2, stage 2 conf vol						
vCu, unblocked vol	1067				1909	1103
tC, single (s)	4.1				6.4	6.2
tC, 2 stage (s)						
tF (s)	2.2				3.5	3.3
p0 queue free %	95				0	0
cM capacity (veh/h)	638				66	238
Direction, Lane #	EB 1	WB 1	SB 1	SB 2		
Volume Total	778	1025	77	384		
Volume Left	32	0	77	0		
Volume Right	0	28	0	384		
cSH	638	1700	66	238		
Volume to Capacity	0.05	0.60	1.15	1.61		
Queue Length 95th (ft)	4	0	151	604		
Control Delay (s)	1.4	0.0	264.6	330.6		
Lane LOS	A		F	F		
Approach Delay (s)	1.4	0.0	319.7			
Approach LOS			F			
Intersection Summary						
Average Delay	65.5					
Intersection Capacity Utilization	79.0%			ICU Level of Service	D	
Analysis Period (min)	15					

HCM Unsignalized Intersection Capacity Analysis

51: Campanella Way & Fr. Herlihy Drive

6/3/2008

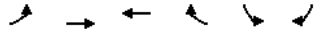

Movement	EBL	EBT	WBT	WBR	SBL	SBR
Lane Configurations		↑	↑		↓	↓
Sign Control		Stop	Yield		Stop	
Volume (vph)	0	45	135	0	56	64
Peak Hour Factor	0.25	0.61	0.70	0.25	0.73	0.82
Hourly flow rate (vph)	0	74	193	0	77	78
Direction, Lane #	EB 1	WB 1	SB 1	SB 2		
Volume Total (vph)	74	193	77	78		
Volume Left (vph)	0	0	77	0		
Volume Right (vph)	0	0	0	78		
Hadj (s)	0.00	0.09	0.77	-0.63		
Departure Headway (s)	4.5	4.5	5.9	4.5		
Degree Utilization, x	0.09	0.24	0.13	0.10		
Capacity (veh/h)	763	772	583	757		
Control Delay (s)	8.0	8.9	8.5	6.8		
Approach Delay (s)	8.0	8.9	7.7			
Approach LOS	A	A	A			
Intersection Summary						
Delay	8.3					
HCM Level of Service	A					
Intersection Capacity Utilization	26.0%		ICU Level of Service	A		
Analysis Period (min)	15					

No-Build 2018

Queues

2: Commonwealth Ave & Lake Street

6/3/2008

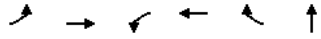

Lane Group	EBL	EBT	WBL	WBT	WBR	NBT
Lane Group Flow (vph)	335	678	302	656	112	402
w/c Ratio	0.71	0.49	1.16	1.17	0.35	1.11
Control Delay	36.2	18.4	140.7	128.9	10.0	110.9
Queue Delay	0.0	0.0	0.0	0.0	0.0	0.0
Total Delay	36.2	18.4	140.7	128.9	10.0	110.9
Queue Length 50th (ft)	159	132	~195	~224	0	~125

HCM Signalized Intersection Capacity Analysis
2: Commonwealth Ave & Lake Street

6/3/2008



Movement	SBR
Lane Configurations	
Ideal Flow (vphpl)	1900
Lane Width	12
Total Lost time (s)	
Lane Util. Factor	
Frpb, ped/bikes	
Fipb, ped/bikes	
Frt	
Flt Protected	
Satd. Flow (prot)	
Flt Permitted	
Satd. Flow (perm)	
Volume (vph)	0
Peak-hour factor, PHF	0.25
Adj. Flow (vph)	0
RTOR Reduction (vph)	0
Lane Group Flow (vph)	0
Confl. Peds. (#/hr)	
Heavy Vehicles (%)	0%
Turn Type	
Protected Phases	
Permitted Phases	
Actuated Green, G (s)	
Effective Green, g (s)	
Actuated g/C Ratio	
Clearance Time (s)	
Vehicle Extension (s)	
Lane Grp Cap (vph)	
v/s Ratio Prot	
v/s Ratio Perm	
v/c Ratio	
Uniform Delay, d1	
Progression Factor	
Incremental Delay, d2	
Delay (s)	
Level of Service	
Approach Delay (s)	
Approach LOS	
Intersection Summary	

Queues
3: Commonwealth Ave & Chestnut Hill

6/3/2008

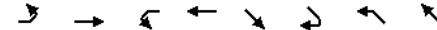

Lane Group	EBL	EBT	WBL	WBT	SET	SER	NWL	NWT
Lane Group Flow (vph)	176	772	223	359	566	58	180	895
v/c Ratio	0.51	1.04	0.84	0.55	1.48	0.16	0.64	1.43
Control Delay	29.4	84.2	42.7	44.5	262.6	25.1	70.0	237.8
Queue Delay	0.0	0.0	0.0	0.0	0.0	0.0	0.0	0.0
Total Delay	29.4	84.2	42.7	44.5	262.6	25.1	70.0	237.8
Queue Length 50th (ft)	92	-316	121	127	-317	21	144	-938
Queue Length 95th (ft)	107	#395	#227	185	#433	40	m105	m498
Internal Link Dist (ft)		1348		1135	4158			919
Turn Bay Length (ft)	200		100			50		
Base Capacity (vph)	386	742	310	649	383	355	280	627
Starvation Cap Reductn	0	0	0	0	0	0	0	0
Spillback Cap Reductn	0	0	0	0	0	0	0	0
Storage Cap Reductn	0	0	0	0	0	0	0	0
Reduced v/c Ratio	0.46	1.04	0.72	0.55	1.48	0.16	0.64	1.43

Intersection Summary
~ Volume exceeds capacity, queue is theoretically infinite. Queue shown is maximum after two cycles.
95th percentile volume exceeds capacity, queue may be longer. Queue shown is maximum after two cycles.
m Volume for 95th percentile queue is metered by upstream signal.

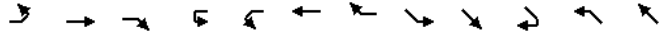

Queues

7: Beacon St & Chestnut Hill Ave

6/3/2008

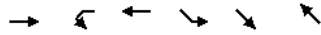

Lane Group	EBT	WBL	WBT	SEL	SET	NWT
Lane Group Flow (vph)	767	176	731	293	810	1000
v/c Ratio	1.92	0.98	0.44	1.31	0.65	1.66
Control Delay	451.2	94.5	29.2	179.1	20.3	323.8
Queue Delay	0.0	0.0	0.0	0.0	0.0	0.0
Total Delay	451.2	94.5	29.2	179.1	20.3	323.8
Queue Length 50th (ft)	~481	95	153	~299	182	~598
Queue Length 95th (ft)	#606	#243	171	m#233	m155	#706
Internal Link Dist (ft)	3431		1419		919	239
Turn Bay Length (ft)		100				
Base Capacity (vph)	399	179	1651	223	1239	602
Starvation Cap Reductn	0	0	0	0	0	0
Spillback Cap Reductn	0	0	0	0	0	0
Storage Cap Reductn	0	0	0	0	0	0
Reduced v/c Ratio	1.92	0.98	0.44	1.31	0.65	1.66

Intersection Summary

- ~ Volume exceeds capacity, queue is theoretically infinite.
Queue shown is maximum after two cycles.
- # 95th percentile volume exceeds capacity, queue may be longer.
Queue shown is maximum after two cycles.
- m Volume for 95th percentile queue is metered by upstream signal.

HCM Signalized Intersection Capacity Analysis

7: Beacon St & Chestnut Hill Ave

6/3/2008

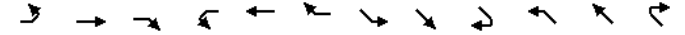

Movement	EBL	EBT	EBR	WBL	WBT	WBR	SEL	SET	SER	NWL	NWT	NWR
Lane Configurations		↕↕		↕	↕↕↕		↕	↕↕			↕↕	
Ideal Flow (vphpl)	1900	1900	1900	1900	1900	1900	1900	1900	1900	1900	1900	1900
Lane Width	11	11	11	11	12	12	10	11	10	14	16	16

HCM Unsignalized Intersection Capacity Analysis

8: Beacon St & Gate House Road

6/3/2008



Movement	EBL	EBT	EBR	WBL	WBT	WBR	NBL	NBT	NBR	SBL	SBT	SBR			
Lane Configurations	↔	↕	↔	↔	↕	↔	↔	↕	↔	↔	↕	↔			
Sign Control	Free			Free			Stop			Stop					
Grade	0%			0%			0%			0%					
Volume (veh/h)	390	700	10	5	625	75	5	5	25	5	225				
Peak Hour Factor	0.99	0.93	0.67	0.50	0.89	0.71	0.42	0.33	0.50	0.84	0.38	0.90			
Hourly flow rate (vph)	394	753	15	10	702	106	12	15	10	30	13	250			
Pedestrians	8			10			5			8					
Lane Width (ft)	12.0			12.0			12.0			12.0					
Walking Speed (ft/s)	4.0			4.0			4.0			4.0					
Percent Blockage	1			1			0			1					
Right turn flare (veh)															
Median type							None			None					
Median storage (veh)															
Upstream signal (ft)															
pX, platoon unblocked															
vC, conflicting volume	816		773			2593		2389		775		2344		771	
vC1, stage 1 conf vol															
vC2, stage 2 conf vol															
vCu, unblocked vol	816		773			2593		2389		775		2344		771	
tC, single (s)	4.1		4.4			7.1		6.5		6.2		7.2		6.5	
tC, 2 stage (s)															
tF (s)	2.2		2.4			3.5		4.0		3.3		3.6		4.0	
p0 queue free %	50		99			0		10		97		0		27	
cM capacity (veh/h)	793		746			2		17		396		4		18	

Direction, Lane #	EB 1	EB 2	WB 1	NB 1	SB 1
Volume Total	394	768	818	37	293
Volume Left	394	0	10	12	30
Volume Right	0	15	106	10	250
cSH	793	1700	746	4	30
Volume to Capacity	0.50	0.45	0.01	8.76	9.85
Queue Length 95th (ft)	70	0	1	Err	Err
Control Delay (s)	13.9	0.0	0.4	Err	Err
Lane LOS	B		A	F	F
Approach Delay (s)	4.7		0.4	Err	Err
Approach LOS				F	F

Intersection Summary				
Average Delay	1431.2			
Intersection Capacity Utilization	112.6%	ICU Level of Service		H
Analysis Period (min)	15			

Queues

13: Washington St & Chestnut Hill

6/3/2008



Lane Group	EBT	WBL	WBT	NBL	NBT	SBL	SBT	SBR
Lane Group Flow (vph)	635	57	553	83	417	119	356	118
v/c Ratio	2.39	0.46	1.20	0.31	0.46	0.89	0.50	0.21
Control Delay	650.0	35.7	138.5	22.8	20.7	81.8	22.4	18.0
Queue Delay	0.0	0.0	0.0	0.0	0.0	0.0	0.0	0.0
Total Delay	650.0	35.7	138.5	22.8	20.7	81.8	22.4	18.0
Queue Length 50th (ft)	~594	24	~386	25	135	52	117	33
Queue Length 95th (ft) m#682	39	#564	76	#367	#139	#348	85	
Internal Link Dist (ft)	985	930	4158	1061				
Turn Bay Length (ft)	50	50	75	50				
Base Capacity (vph)	266	124	460	266	898	134	714	551
Starvation Cap Reductn	0	0	0	0	0	0	0	0
Spillback Cap Reductn	0	0	0	0	0	0	0	0
Storage Cap Reductn	0	0	0	0	0	0	0	0
Reduced v/c Ratio	2.39	0.46	1.20	0.31	0.46	0.89	0.50	0.21

Intersection Summary	
~	Volume exceeds capacity, queue is theoretically infinite. Queue shown is maximum after two cycles.
#	95th percentile volume exceeds capacity, queue may be longer. Queue shown is maximum after two cycles.
m	Volume for 95th percentile queue is metered by upstream signal.

HCM Signalized Intersection Capacity Analysis

13: Washington St & Chestnut Hill

6/3/2008



Movement	EBL	EBT	EBR	WBL	WBT	WBR	NBL	NBT	NBR	SBL	SBT	SBR
Lane Configurations		↕		↕	↕		↕	↕		↕	↕	↕
Ideal Flow (vphpl)	1900	1900	1900	1900	1900	1900	1900	1900	1900	1900	1900	1900
Lane Width	10	11	16	10	11	16	16	16	16	12	12	10
Total Lost time (s)		4.0		4.0	4.0		4.0	4.0		4.0	4.0	4.0
Lane Util. Factor		1.00		1.00	1.00		1.00	1.00		1.00	1.00	1.00
Frt		0.98		1.00	0.95		1.00	0.98		1.00	1.00	0.85
Flt Protected		0.99		0.95	1.00		0.95	1.00		0.95	1.00	1.00
Satd. Flow (prot)		1369		1189	1218		1841	1862		1354	1481	1141
Flt Permitted		0.15		0.16	1.00		0.45	1.00		0.40	1.00	1.00
Satd. Flow (perm)		209		199	1218		879	1862		568	1481	1141
Volume (vph)	60	435	100	35	340	135	65	350	45	80	335	90
Peak-hour factor, PHF	0.86	0.96	0.89	0.61	0.88	0.81	0.78	0.99	0.71	0.67	0.94	0.76
Adj. Flow (vph)	70	453	112	57	386	167	83	354	63	119	356	118
RTOR Reduction (vph)	0	0	0	0	0	0	0	0	0	0	0	0
Lane Group Flow (vph)	0	635	0	57	553	0	83	417	0	119	356	118
Heavy Vehicles (%)	2%	3%	1%	0%	1%	3%	0%	2%	0%	5%	1%	4%
Bus Blockages (#/hr)	0	0	0	26	26	26	0	0	0	0	0	0
Parking (#/hr)	5	5	5	5	5	5				5	5	5
Turn Type	Perm			Perm			Perm			Perm		Perm
Protected Phases		1			1			3			3	
Permitted Phases	1			1			3			3		3

Queues



Queues

18: Commonwealth Ave & South St

6/3/2008



HCM Unsignalized Intersection Capacity Analysis

19: Commonwealth Ave & Foster St

6/3/2008

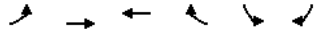

Movement	EBL	EBT	WBT	WBR	SBL	SBR
Lane Configurations		↑↑	↑↑			↑
Sign Control		Free	Free		Stop	
Grade		0%	0%		0%	
Volume (veh/h)	0	660	645	85	0	370
Peak Hour Factor	0.25	0.89	0.96	0.77	0.25	0.90
Hourly flow rate (vph)	0	742	672	110	0	411
Pedestrians		59			59	
Lane Width (ft)		12.0			12.0	
Walking Speed (ft/s)		4.0			4.0	
Percent Blockage		5			5	
Right turn flare (veh)						
Median type					None	
Median storage (veh)						
Upstream signal (ft)			504			
pX, platoon unblocked	0.93				0.93	0.93
vC, conflicting volume	841				1157	509
vC1, stage 1 conf vol						
vC2, stage 2 conf vol						
vCu, unblocked vol	754				1093	396
tC, single (s)	4.1				6.8	6.9
tC, 2 stage (s)						
tF (s)	2.2				3.5	3.3
p0 queue free %	100				100	19
cM capacity (veh/h)	765				187	509
Direction, Lane #	EB 1	EB 2	WB 1	WB 2	SB 1	
Volume Total	371	371	448	334	411	
Volume Left	0	0	0	0	0	
Volume Right	0	0	0	110	411	
cSH	1700	1700	1700	1700	509	
Volume to Capacity	0.22	0.22	0.26	0.20	0.81	
Queue Length 95th (ft)	0	0	0	0	193	
Control Delay (s)	0.0	0.0	0.0	0.0	35.4	
Lane LOS					E	
Approach Delay (s)	0.0		0.0		35.4	
Approach LOS					E	
Intersection Summary						
Average Delay			7.5			





Queues

35: Beacon St & College Rd

6/3/2008

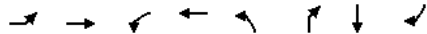

Lane Group	EBL	EBT	WBL	WBT	NBL	NBR	SBT	SBR
Lane Group Flow (vph)	159	866	247	670	146	255	389	28
v/c Ratio	0.63	1.07	1.13	0.65	1.40	9.11	0.64	0.02
Control Delay	33.5	75.1	124.3	15.8	258.2	3724.9	38.0	0.0
Queue Delay	0.0	0.0	0.0	0.0	0.0	0.0	0.0	0.0
Total Delay	33.5	75.1	124.3	15.8	258.2	3724.9	38.0	0.0
Queue Length 50th (ft)	46	363	-80	138	-88	-224	86	0
Queue Length 95th (ft)	#189	#888	#254	337	#211	#407	143	0
Internal Link Dist (ft)		679		1940			600	
Turn Bay Length (ft)	200		200		40			75
Base Capacity (vph)	252	812	218	1037	104	28	608	1264
Starvation Cap Reductn	0	0	0	0	0	0	0	0
Spillback Cap Reductn	0	0	0	0	0	0	0	0
Storage Cap Reductn	0	0	0	0	0	0	0	0
Reduced v/c Ratio	0.63	1.07	1.13	0.65	1.40	9.11	0.64	0.02

Intersection Summary

~ Volume exceeds capacity, queue is theoretically infinite.

Queue shown is maximum after two cycles.

95th percentile volume exceeds capacity, queue may be longer.

Queue shown is maximum after two cycles.

HCM Signalized Intersection Capacity Analysis

35: Beacon St & College Rd

6/3/2008



Movement	EBL	EBT	EBR	WBL	WBT	WBR2	NBL	NBR	NBR2	SBL2	SBL	SBT
Lane Configurations	↔	↔	↔	↔	↔	↔	↔	↔	↔	↔	↔	↔
Ideal Flow (vphpl)	1900	1900	1900	1900	1900	1900	1900	1900	1900	1900	1900	1900
Lane Width	11	12	12	12	12	12	10	12	12	12	12	12
Total Lost time (s)	4.0	4.0		4.0	4.0		4.0	4.0				4.0
Lane Util. Factor	1.00	1.00		1.00	1.00		1.00	1.00				0.95
Frt	1.00	0.98		1.00	0.98		1.00	0.85				1.00
Flt Protected	0.95	1.00		0.95	1.00		0.95	1.00				0.98
Satd. Flow (prot)	1555	1652		1593	1658		1516	1419				3113
Flt Permitted	0.36	1.00		0.10	1.00		0.36	1.00				0.98
Satd. Flow (perm)	589	1652		166	1658		582	1419				3113
Volume (vph)	145	740	80	200	470	35	115	125	75	5	100	200
Peak-hour factor, PHF	0.91	0.96	0.84	0.81	0.78	0.52	0.79	0.84	0.71	0.62	0.80	0.78
Adj. Flow (vph)	159	771	95	247	603	67	146	149	106	8	125	256
RTOR Reduction (vph)	0	5	0	0	4	0	0	28	0	0	0	0
Lane Group Flow (vph)	159	861	0	247	666	0	146	227	0	0	0	389
Heavy Vehicles (%)	1%	2%	0%	2%	1%	7%	0%	2%	3%	0%	2%	3%
Turn Type	Perm			D,P+P			D,Pm	NA				Perm
Protected Phases		3		2	2 3							1
Permitted Phases	3			3			1				1	
Actuated Green, G (s)	39.5	39.5		47.6	50.6		15.2	0.0				15.2
Effective Green, g (s)	40.5	40.5		47.6	51.6		16.2	0.0				16.2
Actuated g/C Ratio	0.47	0.47		0.56	0.60		0.19	0.00				0.19
Clearance Time (s)	5.0	5.0		3.0			5.0					5.0
Vehicle Extension (s)	3.0	3.0		3.0			3.0					3.0
Lane Grp Cap (vph)	279	783		211	1002		110	0				591
v/s Ratio Prot		0.52		c0.10	0.40							
v/s Ratio Perm	0.27			c0.56			c0.25					0.12
v/c Ratio	0.57	1.10		1.17	0.66		1.33	no cap				0.66
Uniform Delay, d1	16.2	22.5		23.2	11.2		34.6	Error				32.0
Progression Factor	1.00	1.00		1.00	1.00		1.00					1.00
Incremental Delay, d2	2.7	63.0		115.6	1.7		196.9	Error				2.7
Delay (s)	18.8	85.5		138.9	12.9		231.5	Error				34.7
Level of Service	B	F		F	B		F	F				C
Approach Delay (s)		75.1			46.8							32.4
Approach LOS		E			D							C

Intersection Summary

HCM Average Control Delay	Error	HCM Level of Service	F
HCM Volume to Capacity ratio	1.05		
Actuated Cycle Length (s)	85.4	Sum of lost time (s)	12.0
Intersection Capacity Utilization	90.9%	ICU Level of Service	E
Analysis Period (min)	15		
c Critical Lane Group			

HCM Signalized Intersection Capacity Analysis



HCM Unsignalized Intersection Capacity Analysis

46: Chestnut Hill Driveway & T. Moore

6/3/2008



Movement	WBL	WBR	NBT	NBR	SBL	SBT
Lane Configurations	↔	↔	↕	↔	↔	↕
Sign Control	Stop		Free			Free
Grade	0%		0%			0%
Volume (veh/h)	60	10	330	155	5	210
Peak Hour Factor	0.69	0.70	0.51	0.88	0.69	0.70
Hourly flow rate (vph)	87	14	647	176	7	300
Pedestrians						
Lane Width (ft)						
Walking Speed (ft/s)						
Percent Blockage						
Right turn flare (veh)						
Median type	None					
Median storage (veh)						
Upstream signal (ft)						
pX, platoon unblocked						
vC, conflicting volume	1050	735			823	
vC1, stage 1 conf vol						
vC2, stage 2 conf vol						
vCu, unblocked vol	1050	735			823	
tC, single (s)	6.9	6.2			4.2	
tC, 2 stage (s)						
tF (s)	3.9	3.3			2.3	
p0 queue free %	58	97			99	
cM capacity (veh/h)	205	421			753	
Direction, Lane #	WB 1	NB 1	SB 1			

HCM Unsignalized Intersection Capacity Analysis

51: Campanella Way & Fr. Herlihy Drive

6/3/2008



Movement	EBL	EBT	WBT	WBR	SBL	SBR
Lane Configurations		↑	↑		↓	↓
Sign Control		Stop	Yield		Stop	Stop
Volume (vph)	0	15	225	0	75	170
Peak Hour Factor	0.25	0.71	0.70	0.25	0.89	0.83
Hourly flow rate (vph)	0	21	321	0	84	205
Direction, Lane #	EB 1	SBR				

Queues

2: Commonwealth Ave & Lake Street

6/3/2008



Lane Group	EBL	EBT	WBL	WBT	WBR	NBT
Lane Group Flow (vph)	195	665	293	791	138	607
v/c Ratio	0.62	0.63	0.67	0.85	0.33	1.46
Control Delay	46.8	30.2	39.3	41.8	7.7	248.5
Queue Delay	0.0	0.0	0.0	0.0	0.0	0.0
Total Delay	46.8	30.2	39.3	41.8	7.7	248.5
Queue Length 50th (ft)	114	190	160	242	2	~276
Queue Length 95th (ft)	196	213	247	#374	45	#384
Internal Link Dist (ft)		1877		667		202
Turn Bay Length (ft)	200		300		200	
Base Capacity (vph)	317	1234	455	968	436	416
Starvation Cap Reductn	0	0	0	0	0	0
Spillback Cap Reductn	0	0	0	0	0	0
Storage Cap Reductn	0	0	0	0	0	0
Reduced v/c Ratio	0.62	0.54	0.64	0.82	0.32	1.46

Intersection Summary

~ Volume exceeds capacity, queue is theoretically infinite.
Queue shown is maximum after two cycles.

95th percentile volume exceeds capacity, queue may be longer.
Queue shown is maximum after two cycles.

HCM Signalized Intersection Capacity Analysis

2: Commonwealth Ave & Lake Street

6/3/2008

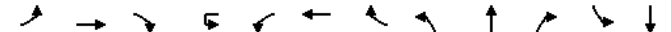

Movement	EBL	EBT	EBR	WBU	WBL	WBT	WBR	NBL	NBT	NBR	SBL	SBT
Lane Configurations	↔	↔↔			↔	↔↔	↔		↔↔		↔	↔
Ideal Flow (vphpl)	1900	1900	1900	1900	1900	1900	1900	1900	1000	1900	1900	1900
Lane Width	11	12	12	12	11	12	12	10	10	10	12	12
Total Lost time (s)	4.0	4.0			4.0	4.0	4.0		4.0			
Lane Util. Factor	1.00	0.95			1.00	0.95	1.00		0.95			
Frpb, ped/bikes	1.00	1.00			1.00	1.00	0.82		1.00			
Flpb, ped/bikes	1.00	1.00			1.00	1.00	1.00		1.00			
Flt	1.00	1.00			1.00	1.00	0.85		0.97			
Flt Protected	0.95	1.00			0.95	1.00	1.00		0.98			
Satd. Flow (prot)	1570	3180			1528	3249	1174		1522			
Flt Permitted	0.95	1.00			0.95	1.00	1.00		0.98			
Satd. Flow (perm)	1570	3180			1528	3249	1174		1522			
Volume (vph)	170	525	5	20	225	720	120	165	255	80	0	0
Peak-hour factor, PHF	0.87	0.80	0.58	0.92	0.83	0.91	0.87	0.84	0.84	0.75	0.25	0.25
Adj. Flow (vph)	195	656	9	22	271	791	138	196	304	107	0	0
RTOR Reduction (vph)	0	1	0	0	0	0	96	0	16	0	0	0
Lane Group Flow (vph)	195	664	0	0	293	791	42	0	591	0	0	0
Confl. Peds. (#/hr)							54					
Heavy Vehicles (%)	0%	2%	0%	0%	3%	0%	1%	1%	0%	1%	0%	0%
Turn Type	Prot			Split	Split		Perm	Split				
Protected Phases	1	1 2		3	3	3		4	4			
Permitted Phases							3					
Actuated Green, G (s)	20.1	32.8			28.3	28.3	28.3		26.1			
Effective Green, g (s)	20.1	32.8			28.3	28.3	28.3		26.1			
Actuated g/C Ratio	0.20	0.33			0.29	0.29	0.29		0.26			
Clearance Time (s)	4.0				4.0	4.0	4.0		4.0			
Vehicle Extension (s)	3.0				3.0	3.0	3.0		3.0			
Lane Grp Cap (vph)	318	1051			436	927	335		400			
v/s Ratio Prot	0.12	c0.21			0.19	c0.24			c0.39			
v/s Ratio Perm							0.04					
v/c Ratio	0.61	0.63			0.67	0.85	0.13		1.48			
Uniform Delay, d1	36.0	28.1			31.3	33.5	26.3		36.6			
Progression Factor	1.00	1.00			1.00	1.00	1.00		1.00			
Incremental Delay, d2	8.6	1.2			4.1	7.7	0.2		227.8			
Delay (s)	44.6	29.3			35.4	41.2	26.5		264.3			
Level of Service	D	C			D	D	C		F			
Approach Delay (s)		32.8				38.1			264.3			0.0
Approach LOS		C				D			F			A

Intersection Summary

HCM Average Control Delay	87.5	HCM Level of Service	F
HCM Volume to Capacity ratio	0.96		
Actuated Cycle Length (s)	99.2	Sum of lost time (s)	12.0
Intersection Capacity Utilization	73.0%	ICU Level of Service	C
Analysis Period (min)	15		

c Critical Lane Group

HCM Signalized Intersection Capacity Analysis
2: Commonwealth Ave & Lake Street

6/3/2008



Movement	SBR
Lane Configurations	
Ideal Flow (vphpl)	1900
Lane Width	12
Total Lost time (s)	
Lane Util. Factor	
Frbp, ped/bikes	
Fipb, ped/bikes	
Frt	
Flt Protected	
Satd. Flow (prot)	
Flt Permitted	
Satd. Flow (perm)	
Volume (vph)	0
Peak-hour factor, PHF	0.25
Adj. Flow (vph)	0
RTOR Reduction (vph)	0
Lane Group Flow (vph)	0
Confl. Peds. (#/hr)	
Heavy Vehicles (%)	0%
Turn Type	
Protected Phases	
Permitted Phases	
Actuated Green, G (s)	
Effective Green, g (s)	
Actuated g/C Ratio	
Clearance Time (s)	
Vehicle Extension (s)	
Lane Grp Cap (vph)	
v/s Ratio Prot	
v/s Ratio Perm	
v/c Ratio	
Uniform Delay, d1	
Progression Factor	
Incremental Delay, d2	
Delay (s)	
Level of Service	
Approach Delay (s)	
Approach LOS	
Intersection Summary	

Queues
3: Commonwealth Ave & Chestnut Hill

6/3/2008

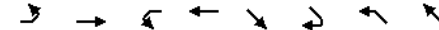

Lane Group	EBL	EBT	WBL	WBT	SET	SER	NWL	NWT
Lane Group Flow (vph)	144	664	247	464	598	42	227	716
v/c Ratio	0.46	0.88	0.85	0.72	1.54	0.12	0.79	1.10
Control Delay	28.1	50.4	41.5	50.9	288.9	25.7	62.4	101.4
Queue Delay	0.0	0.0	0.0	0.0	0.0	0.0	0.0	0.0
Total Delay	28.1	50.4	41.5	50.9	288.9	25.7	62.4	101.4
Queue Length 50th (ft)	74	214	136	174	~342	16	121	~622
Queue Length 95th (ft)	107	#358	#245	#253	#460	34	#213	#797
Internal Link Dist (ft)		1348		1135	4158			919
Turn Bay Length (ft)	200		100			50		
Base Capacity (vph)	366	758	344	642	388	364	286	648
Starvation Cap Reductn	0	0	0	0	0	0	0	0
Spillback Cap Reductn	0	0	0	0	0	0	0	0
Storage Cap Reductn	0	0	0	0	0	0	0	0
Reduced v/c Ratio	0.39	0.88	0.72	0.72	1.54	0.12	0.79	1.10

Intersection Summary
~ Volume exceeds capacity, queue is theoretically infinite. Queue shown is maximum after two cycles.
95th percentile volume exceeds capacity, queue may be longer. Queue shown is maximum after two cycles.

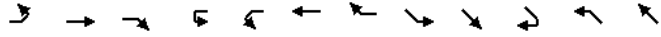

Queues

7: Beacon St & Chestnut Hill Ave

6/3/2008

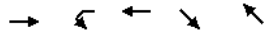

Lane Group	EBT	WBL	WBT	SET	NWT
Lane Group Flow (vph)	692	205	821	989	756
w/c Ratio	1.99	1.40	0.60	0.62	0.98
Control Delay	482.9	248.9	40.4	24.2	51.8
Queue Delay	0.0	0.0	0.0	0.0	0.0
Total Delay	482.9	248.9	40.4	24.2	51.8

HCM Unsignalized Intersection Capacity Analysis

8: Beacon St & Gate House Road

6/3/2008



Movement	EBL	EBT	EBR	WBL	WBT	WBR	NBL	NBT	NBR	SBL	SBT	SBR					
Lane Configurations	↖	↗			↕			↕			↕						
Sign Control	Free			Free			Stop			Stop							
Grade	0%			0%			0%			0%							
Volume (veh/h)	245	505	5	5	680	75	5	5	5	105	5	310					
Peak Hour Factor	0.92	0.85	1.00	0.38	0.90	0.75	0.58	0.38	0.25	0.84	0.50	0.93					
Hourly flow rate (vph)	266	594	5	13	756	100	9	13	20	125	10	333					
Pedestrians	29			26			2			25							
Lane Width (ft)	12.0			12.0			12.0			12.0							
Walking Speed (ft/s)	4.0			4.0			4.0			4.0							
Percent Blockage	2			2			0			2							
Right turn flare (veh)																	
Median type							None			None							
Median storage (veh)																	
Upstream signal (ft)																	
pX, platoon unblocked																	
vC, conflicting volume	881		601			2330		2038		625		2036		1991		860	
vC1, stage 1 conf vol																	
vC2, stage 2 conf vol																	
vCu, unblocked vol	881		601			2330		2038		625		2036		1991		860	
tC, single (s)	4.1		4.1			7.1		6.5		6.2		7.1		6.5		6.3	
tC, 2 stage (s)																	
tF (s)	2.2		2.2			3.5		4.0		3.3		3.5		4.0		3.4	
p0 queue free %	65		99			0		63		96		0		74		0	
cM capacity (veh/h)	756		984			0		36		477		20		38		333	

Direction, Lane #	EB 1	EB 2	WB 1	NB 1	SB 1
Volume Total	266	599	869	42	468
Volume Left	266	0	13	9	125
Volume Right	0	5	100	20	333
cSH	756	1700	984	0	62
Volume to Capacity	0.35	0.35	0.01	Err	7.52
Queue Length 95th (ft)	40	0	1	Err	Err
Control Delay (s)	12.3	0.0	0.4	Err	Err
Lane LOS	B		A	F	F
Approach Delay (s)	3.8		0.4		Err
Approach LOS			F		F

Intersection Summary				
Average Delay	Err			
Intersection Capacity Utilization	120.9%	ICU Level of Service		H
Analysis Period (min)	15			

Queues

13: Washington St & Market Street

6/3/2008



Lane Group	EBT	WBL	WBT	NBL	NBT	SBL	SBT	SBR
Lane Group Flow (vph)	712	36	692	107	343	155	464	119
v/c Ratio	14.83	0.27	1.13	0.60	0.49	0.71	0.82	0.27
Control Delay	6232.5	28.5	106.5	38.2	25.5	42.5	38.1	22.2
Queue Delay	0.0	0.0	0.0	0.0	0.0	0.0	0.0	0.0
Total Delay	6232.5	28.5	106.5	38.2	25.5	42.5	38.1	22.2
Queue Length 50th (ft)	~920	13	~514	50	151	76	242	48
Queue Length 95th (ft) m#837	37	#873	#122	255	#185	#453	70	
Internal Link Dist (ft)	985	930	4158	1061				
Turn Bay Length (ft)	50	50	75	50				
Base Capacity (vph)	48	133	611	188	747	230	598	474
Starvation Cap Reductn	0	0	0	0	0	0	0	0
Spillback Cap Reductn	0	0	0	0	0	0	0	0
Storage Cap Reductn	0	0	0	0	0	0	0	0
Reduced v/c Ratio	14.83	0.27	1.13	0.57	0.46	0.67	0.78	0.25

Intersection Summary	
~	Volume exceeds capacity, queue is theoretically infinite. Queue shown is maximum after two cycles.
#	95th percentile volume exceeds capacity, queue may be longer. Queue shown is maximum after two cycles.
m	Volume for 95th percentile queue is metered by upstream signal.

HCM Signalized Intersection Capacity Analysis

13: Washington St & Market Street

6/3/2008



Movement	EBL	EBT	EBR	WBL	WBT	WBR	NBL	NBT	NBR	SBL	SBT	SBR
Lane Configurations		↕		↕	↕		↕	↕		↕	↕	↕
Ideal Flow (vphpl)	1900	1900	1900	1900	1900	1900	1900	1900	1900	1900	1900	1900
Lane Width	10	11	16	10	11	16	16	16	16	12	12	10
Total Lost time (s)		4.0		4.0	4.0		4.0	4.0		4.0	4.0	4.0
Lane Util. Factor		1.00		1.00	1.00		1.00	1.00		1.00	1.00	1.00
Frt		0.96		1.00	0.96		1.00	0.98		1.00	1.00	0.85
Flt Protected		0.99		0.95	1.00		0.95	1.00		0.95	1.00	1.00
Satd. Flow (prot)		1373		1189	1228		1823	1871		1421	1496	1187
Flt Permitted		0.22		0.27	1.00		0.26	1.00		0.40	1.00	1.00
Satd. Flow (perm)		311		344	1228		505	1871		594	1496	1187
Volume (vph)	85	365	180	25	450	140	90	285	20	135	450	80
Peak-hour factor, PHF	0.74	0.92	0.90	0.69	0.91	0.71	0.84	0.94	0.50	0.87	0.97	0.67
Adj. Flow (vph)	115	397	200	36	495	197	107	303	40	155	464	119

Queues

16: Washington St & Brock St

6/3/2008

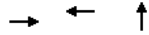

Lane Group	EBT	WBT	NBT
Lane Group Flow (vph)	646	564	538
v/c Ratio	1.74	0.82	0.72
Control Delay	367.9	46.1	30.2
Queue Delay	0.0	0.0	0.0
Total Delay	367.9	46.1	30.2
Queue Length 50th (ft)	~615	262	241
Queue Length 95th (ft)	#837	m#436	#569
Internal Link Dist (ft)	966	802	965
Turn Bay Length (ft)			
Base Capacity (vph)	371	684	744
Starvation Cap Reductn	0	0	0
Spillback Cap Reductn	0	0	0
Storage Cap Reductn	0	0	0
Reduced v/c Ratio	1.74	0.82	0.72

Intersection Summary

~ Volume exceeds capacity, queue is theoretically infinite.
Queue shown is maximum after two cycles.

95th percentile volume exceeds capacity, queue may be longer.
Queue shown is maximum after two cycles.

m Volume for 95th percentile queue is metered by upstream signal.

HCM Signalized Intersection Capacity Analysis

16: Washington St & Brock St

6/3/2008



Movement	EBL	EBT	EBR	WBL	WBT	WBR	NBL	NBT	NBR	SBL	SBT	SBR
Lane Configurations		↑			↑			↑				
Ideal Flow (vphpl)	1900	1900	1900	1900	1900	1900	1900	1900	1900	1900	1900	1900

Queues

18: Commonwealth Ave & South St

6/3/2008

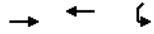

Lane Group	EBT	WBT	SWL
Lane Group Flow (vph)	821	684	220
v/c Ratio	1.11	0.41	0.40
Control Delay	86.4	12.2	8.3
Queue Delay	0.0	0.0	0.0
Total Delay	86.4	12.2	8.3
Queue Length 50th (ft)	~185	72	10
Queue Length 95th (ft)	#371	178	45
Internal Link Dist (ft)	424	1348	723
Turn Bay Length (ft)			
Base Capacity (vph)	742	1669	545
Starvation Cap Reductn	0	0	0
Spillback Cap Reductn	0	0	0
Storage Cap Reductn	0	0	0
Reduced v/c Ratio	1.11	0.41	0.40

Intersection Summary

~ Volume exceeds capacity, queue is theoretically infinite.

Queue shown is maximum after two cycles.

95th percentile volume exceeds capacity, queue may be longer.

Queue shown is maximum after two cycles.

HCM Signalized Intersection Capacity Analysis

18: Commonwealth Ave & South St

6/3/2008

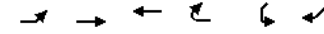

Movement	EBL	EBT	WBT	WBR	SWL	SWR
Lane Configurations		↑↑	↑↑		∩	∩
Ideal Flow (vphpl)	1900	1900	1900	1900	1900	1900
Total Lost time (s)		4.0	4.0		4.0	
Lane Util. Factor		0.95	0.95		1.00	
Frt		1.00	1.00		0.89	
Flt Protected		1.00	1.00		0.99	
Satd. Flow (prot)		3245	3249		1331	
Flt Permitted		0.93	1.00		0.99	
Satd. Flow (perm)		3032	3249		1331	
Volume (vph)	5	665	595	0	30	160
Peak-hour factor, PHF	0.25	0.83	0.87	0.25	0.75	0.89
Adj. Flow (vph)	20	801	684	0	40	180
RTOR Reduction (vph)	0	0	0	0	125	0
Lane Group Flow (vph)	0	821	684	0	95	0
Heavy Vehicles (%)	0%	0%	0%	0%	0%	1%
Parking (#/hr)					2	2
Turn Type						
Protected Phases		1	1		3	
Permitted Phases						
Actuated Green, G (s)		34.4	34.4		21.3	
Effective Green, g (s)		34.4	34.4		21.3	
Actuated g/C Ratio		0.49	0.49		0.30	
Clearance Time (s)		4.0	4.0		4.0	
Vehicle Extension (s)		3.0	3.0		3.0	
Lane Grp Cap (vph)		1484	1590		403	
v/s Ratio Prot			0.21		c0.07	
v/s Ratio Perm		c0.27				
v/c Ratio		0.55	0.43		0.23	
Uniform Delay, d1		12.6	11.6		18.4	
Progression Factor		1.00	1.00		1.00	
Incremental Delay, d2		1.5	0.9		1.4	
Delay (s)		14.1	12.5		19.7	
Level of Service		B	B		B	
Approach Delay (s)		14.1	12.5		19.7	
Approach LOS		B	B		B	

Intersection Summary

HCM Average Control Delay 14.2 HCM Level of Service B

HCM Volume to Capacity ratio 0.43

Actuated Cycle Length (s) 70.3 Sum of lost time (s) 14.6

Intersection Capacity Utilization 43.8% ICU Level of Service A

Analysis Period (min) 15

c Critical Lane Group

HCM Unsignalized Intersection Capacity Analysis

19: Commonwealth Ave & Foster St

6/3/2008

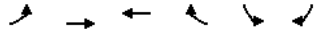

Movement	EBL	EBT	WBT	WBR	SBL	SBR
Lane Configurations		↑↑	↑↑			↑
Sign Control		Free	Free		Stop	
Grade		0%	0%		0%	
Volume (veh/h)	0	660	715	55	0	375
Peak Hour Factor	0.25	0.83	0.94	0.74	0.25	0.89
Hourly flow rate (vph)	0	795	761	74	0	421
Pedestrians					65	
Lane Width (ft)					12.0	
Walking Speed (ft/s)					4.0	
Percent Blockage					5	
Right turn flare (veh)						
Median type					None	
Median storage (veh)						
Upstream signal (ft)			504			
pX, platoon unblocked	0.90				0.90	0.90
vC, conflicting volume	900				1260	482
vC1, stage 1 conf vol						
vC2, stage 2 conf vol						
vCu, unblocked vol	774				1176	309
tC, single (s)	4.1				6.8	6.9
tC, 2 stage (s)						
tF (s)	2.2				3.5	3.3
p0 queue free %	100				100	28
cM capacity (veh/h)	722				159	588
Direction, Lane #	EB 1	EB 2	WB 1	WB 2	SB 1	
Volume Total	398	398	507	328	421	
Volume Left	0	0	0	0	0	
Volume Right	0	0	0	74	421	
cSH	1700	1700	1700	1700	588	
Volume to Capacity	0.23	0.23	0.30	0.19	0.72	
Queue Length 95th (ft)	0	0	0	0	148	
Control Delay (s)	0.0	0.0	0.0	0.0	25.1	
Lane LOS					D	
Approach Delay (s)	0.0		0.0		25.1	
Approach LOS					D	
Intersection Summary						
Average Delay			5.1			

HCM Signalized Intersection Capacity Analysis

20: Washington St & Foster St

6/3/2008



Movement	EBL	EBT	EBR	WBL	WBT	WBR	NBL	NBT	NBR	SBL	SBT	SBR	
Lane Configurations		↔		↔	↔		↔	↔	↔	↔	↔	↔	
Ideal Flow (vphpl)	1900	1900	1900	1900	1900	1900	1900	1900	1900	1900	1900	1900	
Lane Width	12	12	10	10	12	12	10	10	10	12	10	10	
Total Lost time (s)		4.0		4.0	4.0		4.0		4.0		4.0		
Lane Util. Factor		1.00		1.00	1.00		1.00		1.00		1.00		
Frt		0.97		1.00	1.00		1.00		0.85		0.98		
Flt Protected		1.00		0.95	1.00		0.95		1.00		0.99		
Satd. Flow (prot)		1589		1501	1605		1486		1184		1540		
Flt Permitted		1.00		0.11	1.00		0.40		1.00		0.99		
Satd. Flow (perm)		1589		179	1605		630		1184		1540		
Volume (vph)	0	455	150	230	425	0	70	0	135	45	140	40	
Peak-hour factor, PHF	0.25	0.86	0.87	0.87	0.94	0.25	0.90	0.25	0.88	0.70	0.88	0.84	
Adj. Flow (vph)	0	529	172	264	452	0	78	0	153	64	159	48	
RTOR Reduction (vph)	0	12	0	0	0	0	0	0	153	0	0	0	
Lane Group Flow (vph)	0	689	0	264	452	0	78	0	0	0	271	0	
Heavy Vehicles (%)	0%	5%	1%	1%	4%	0%	2%	0%	2%	0%	0%	0%	
Bus Blockages (#/hr)	0	0	6	0	6	0	0	0	0	0	0	0	
Parking (#/hr)									2	2		2	
Turn Type			pm+pt				D.Pm			NA	Perm		
Protected Phases		1		9	1							3	
Permitted Phases				1			3			3			
Actuated Green, G (s)		35.4		67.7	35.4		22.3		0.0		22.3		
Effective Green, g (s)		35.4		65.7	35.4		22.3		0.0		22.3		
Actuated g/C Ratio		0.35		0.66	0.35		0.22		0.00		0.22		
Clearance Time (s)		4.0		2.0	4.0		4.0				4.0		

HCM Unsignalized Intersection Capacity Analysis

26: Commonwealth Ave & Campus Driveway

6/3/2008

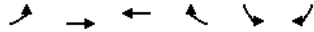

Movement	EBL	EBT	WBT	WBR	SBL	SBR
Lane Configurations		↑↑	↑↑			↑
Sign Control	Free	Free	Free		Stop	
Grade	0%	0%	0%		0%	
Volume (veh/h)	0	635	1020	5	0	55
Peak Hour Factor	0.25	0.83	0.93	0.75	0.25	0.89
Hourly flow rate (vph)	0	765	1097	7	0	62
Pedestrians		101			101	
Lane Width (ft)		12.0			12.0	
Walking Speed (ft/s)		4.0			4.0	
Percent Blockage		8			8	
Right turn flare (veh)						
Median type					None	
Median storage (veh)						
Upstream signal (ft)		747				
pX, platoon unblocked					0.86	
vC, conflicting volume	1204				1584	754
vC1, stage 1 conf vol						
vC2, stage 2 conf vol						
vCu, unblocked vol	1204				1515	754
tC, single (s)	4.1				6.8	6.9
tC, 2 stage (s)						
tF (s)	2.2				3.5	3.3
p0 queue free %	100				100	79
cM capacity (veh/h)	537				88	299
Direction, Lane #	EB 1	EB 2	WB 1	WB 2	SB 1	
Volume Total	383	383	731	372	62	
Volume Left	0	0	0	0	0	
Volume Right	0	0	0	7	62	
cSH	1700	1700	1700	1700	299	
Volume to Capacity	0.23	0.23	0.43	0.22	0.21	
Queue Length 95th (ft)	0	0	0	0	19	
Control Delay (s)	0.0	0.0	0.0	0.0	20.2	
Lane LOS					C	
Approach Delay (s)	0.0		0.0		20.2	
Approach LOS					C	
Intersection Summary						
Average Delay			0.6			

HCM Unsignalized Intersection Capacity Analysis

33: Beacon St & Reservoir Rd

6/3/2008

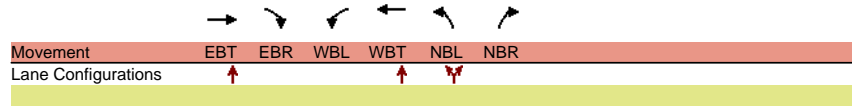

→ → ↘ ↙ ← ↻ ↺ ↻ ↻ ↻ ↻ ↓





HCM Unsignalized Intersection Capacity Analysis

46: Chestnut Hill Driveway & T. Moore

6/3/2008



Movement	WBL	WBR	NBT	NBR	SBL	SBT
Lane Configurations	↔	↔	↔	↔	↔	↔
Sign Control	Stop		Free			Free
Grade	0%		0%			0%
Volume (veh/h)	55	15	240	85	40	385
Peak Hour Factor	0.69	0.70	0.51	0.88	0.69	0.70
Hourly flow rate (vph)	80	21	471	97	58	550
Pedestrians						
Lane Width (ft)						
Walking Speed (ft/s)						
Percent Blockage						
Right turn flare (veh)						
Median type	None					
Median storage (veh)						
Upstream signal (ft)						
pX, platoon unblocked						
vC, conflicting volume	1185	519			567	
vC1, stage 1 conf vol						
vC2, stage 2 conf vol						
vCu, unblocked vol	1185	519			567	
tC, single (s)	6.9	6.2			4.2	
tC, 2 stage (s)						
tF (s)	3.9	3.3			2.3	
p0 queue free %	50	96			94	
cM capacity (veh/h)	159	559			943	

Direction, Lane #	WB 1	NB 1	SB 1
Volume Total	101	567	608
Volume Left	80	0	58
Volume Right	21	97	0
cSH	188	1700	943
Volume to Capacity	0.54	0.33	0.06
Queue Length 95th (ft)	70	0	5
Control Delay (s)	44.6	0.0	1.6
Lane LOS	E		A
Approach Delay (s)	44.6	0.0	1.6
Approach LOS	E		A

Intersection Summary			
Average Delay		4.3	
Intersection Capacity Utilization	59.2%		ICU Level of Service B
Analysis Period (min)	15		

HCM Unsignalized Intersection Capacity Analysis

49: Beacon St Garage &

6/3/2008

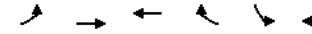

Movement	EBL	EBT	WBT	WBR	SBL	SBR
Lane Configurations	↔	↔	↔	↔	↔	↔
Sign Control	Free	Free			Stop	↔
Grade	0%	0%			0%	
Volume (veh/h)	25	690	975	25	50	100
Peak Hour Factor	0.78	0.88	0.93	0.79	0.64	0.25
Hourly flow rate (vph)	32	784	1048	32	78	400
Pedestrians		50	47		42	
Lane Width (ft)	14.0	14.0			12.0	
Walking Speed (ft/s)	4.0	4.0			4.0	
Percent Blockage	5	5			4	
Right turn flare (veh)						
Median type	None					
Median storage (veh)						
Upstream signal (ft)						
pX, platoon unblocked						
vC, conflicting volume	1122				2001	1156
vC1, stage 1 conf vol						
vC2, stage 2 conf vol						
vCu, unblocked vol	1122				2001	1156
tC, single (s)	4.1				6.4	6.2
tC, 2 stage (s)						
tF (s)	2.2				3.5	3.3
p0 queue free %	95				0	0
cM capacity (veh/h)	608				58	222

Direction, Lane #	EB 1	WB 1	SB 1	SB 2
Volume Total	816	1080	78	400
Volume Left	32	0	78	0
Volume Right	0	32	0	400
cSH	608	1700	58	222
Volume to Capacity	0.05	0.64	1.35	1.80
Queue Length 95th (ft)	4	0	170	692
Control Delay (s)	1.5	0.0	353.8	416.3
Lane LOS	A		F	F
Approach Delay (s)	1.5	0.0	406.0	
Approach LOS			F	

Intersection Summary			
Average Delay		82.3	
Intersection Capacity Utilization	80.9%		ICU Level of Service D
Analysis Period (min)	15		

HCM Unsignalized Intersection Capacity Analysis

51: Campanella Way & Fr. Herlihy Drive

6/3/2008



Movement	EBL	EBT	WBT	WBR	SBL	SBR
Lane Configurations		↑	↑		↓	↓
Sign Control		Stop	Yield		Stop	
Volume (vph)	0	45	135	0	60	65
Peak Hour Factor	0.25	0.61	0.70	0.25	0.73	0.82
Hourly flow rate (vph)	0	74	193	0	82	79
Direction, Lane #	EB 1	WB 1	SB 1	SB 2		
Volume Total (vph)	74	193	82	79		
Volume Left (vph)	0	0	82	0		
Volume Right (vph)	0	0	0	79		
Hadj (s)	0.00	0.09	0.77	-0.63		
Departure Headway (s)	4.5	4.5	5.9	4.5		
Degree Utilization, x	0.09	0.24	0.13	0.10		
Capacity (veh/h)	759	768	583	757		

Build 2018

Queues

2: Commonwealth Ave & Lake Street

6/3/2008

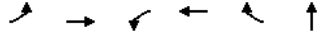

Lane Group	EBL	EBT	WBL	WBT	WBR	NBT
------------	-----	-----	-----	-----	-----	-----

HCM Signalized Intersection Capacity Analysis

2: Commonwealth Ave & Lake Street

6/3/2008



Movement	SBR
Lane Configurations	
Ideal Flow (vphpl)	1900
Lane Width	12
Total Lost time (s)	
Lane Util. Factor	

HCM Signalized Intersection Capacity Analysis

3: Commonwealth Ave & Chestnut Hill

6/3/2008

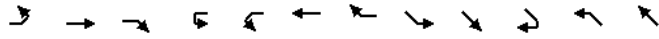

Movement	EBL	EBT	EBR	WBU	WBL	WBT	WBR	SEL	SET	SER	NWL	NWT
Lane Configurations	↔	↕	↔	↔	↕	↕	↔	↔	↕	↕	↔	↔
Ideal Flow (vphpl)	1900	1900	1900	1900	1900	1900	1900	1900	1900	1900	1900	1900
Lane Width	12	12	12	12	12	10	10	12	12	12	12	12
Total Lost time (s)	4.0	4.0			4.0	4.0			4.0	4.0	4.0	4.0
Lane Util. Factor	1.00	0.95			1.00	0.95			0.95	1.00	1.00	1.00
Frt	1.00	0.95			1.00	0.99			1.00	0.85	1.00	0.96
Flt Protected	0.95	1.00			0.95	1.00			0.99	1.00	0.95	1.00
Satd. Flow (prot)	1577	2940			1578	2803			3057	1398	1533	1541
Flt Permitted	0.38	1.00			0.14	1.00			0.52	1.00	0.23	1.00
Satd. Flow (perm)	637	2940			241	2803			1584	1398	366	1541
Volume (vph)	123	399	230	5	205	318	15	35	450	40	142	540
Peak-hour factor, PHF	0.68	0.81	0.81	0.92	0.94	0.92	0.46	0.49	0.91	0.69	0.75	0.82
Adj. Flow (vph)	181	493	284	5	218	346	33	71	495	58	189	659
RTOR Reduction (vph)	0	65	0	0	0	5	0	0	0	17	0	11
Lane Group Flow (vph)	181	712	0	0	223	374	0	0	566	41	189	884
Heavy Vehicles (%)	3%	3%	7%	2%	3%	4%	36%	3%	6%	4%	6%	5%
Turn Type	pm+pt			pm+pt			Perm		Perm	D.P+P		
Protected Phases	9	1			9	1			3		4	3 4
Permitted Phases	1				1		3		3		3	
Actuated Green, G (s)	45.0	27.6			45.0	27.6			29.0	29.0	44.0	48.0
Effective Green, g (s)	43.0	27.6			43.0	27.6			29.0	29.0	44.0	48.0
Actuated g/C Ratio	0.36	0.23			0.36	0.23			0.24	0.24	0.37	0.40
Clearance Time (s)	2.0	4.0			2.0	4.0			4.0	4.0	4.0	4.0
Vehicle Extension (s)	3.0	3.0			3.0	3.0			3.0	3.0	3.0	
Lane Grp Cap (vph)	349	676			258	645			383	338	280	616
v/s Ratio Prot	0.07	c0.24			c0.11	0.13					0.08	c0.57
v/s Ratio Perm	0.12				0.20				0.36	0.03	0.16	
v/c Ratio	0.52	1.05			0.86	0.58			1.48	0.12	0.68	1.44
Uniform Delay, d1	28.2	46.2			31.4	41.0			45.5	35.5	40.9	36.0
Progression Factor	1.00	1.00			1.00	1.00			1.00	1.00	1.75	1.86
Incremental Delay, d2	1.3	49.3			24.6	3.8			228.7	0.7	0.6	196.8
Delay (s)	29.5	95.5			56.0	44.8			274.2	36.3	72.2	263.9
Level of Service	C	F			E	D			F	D	E	F
Approach Delay (s)		83.0				48.9			252.1			230.4
Approach LOS		F				D			F			F

Intersection Summary

HCM Average Control Delay	157.9	HCM Level of Service	F
HCM Volume to Capacity ratio	1.22		
Actuated Cycle Length (s)	120.0	Sum of lost time (s)	29.0
Intersection Capacity Utilization	105.1%	ICU Level of Service	G
Analysis Period (min)	15		
c Critical Lane Group			

HCM Signalized Intersection Capacity Analysis

3: Commonwealth Ave & Chestnut Hill

6/3/2008



Movement	NWR
Lane Configurations	↔
Ideal Flow (vphpl)	1900
Lane Width	12
Total Lost time (s)	
Lane Util. Factor	
Frt	
Flt Protected	
Satd. Flow (prot)	
Flt Permitted	
Satd. Flow (perm)	
Volume (vph)	175
Peak-hour factor, PHF	0.74
Adj. Flow (vph)	236
RTOR Reduction (vph)	0
Lane Group Flow (vph)	0
Heavy Vehicles (%)	11%

Turn Type			
Protected Phases			
Permitted Phases			
Actuated Green, G (s)			
Effective Green, g (s)			
Actuated g/C Ratio			
Clearance Time (s)			
Vehicle Extension (s)			
Lane Grp Cap (vph)			
v/s Ratio Prot			
v/s Ratio Perm			
v/c Ratio			
Uniform Delay, d1			
Progression Factor			
Incremental Delay, d2			
Delay (s)			
Level of Service			
Approach Delay (s)			
Approach LOS			

Intersection Summary

HCM Average Control Delay		HCM Level of Service	
HCM Volume to Capacity ratio			
Actuated Cycle Length (s)		Sum of lost time (s)	
Intersection Capacity Utilization		ICU Level of Service	
Analysis Period (min)			
c Critical Lane Group			

Queues

7: Beacon St & Chestnut Hill Ave

6/3/2008

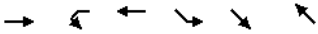

↗ → ↘ ↙ ← ↖



Queues

16: Washington St & Brock St

6/3/2008

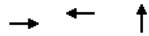

Lane Group	EBT	WBT	NBT
Lane Group Flow (vph)	563	531	557
v/c Ratio	1.07	0.88	0.71
Control Delay	88.4	59.3	26.4
Queue Delay	0.0	0.0	0.0
Total Delay	88.4	59.3	26.4
Queue Length 50th (ft)	~360	292	208
Queue Length 95th (ft)	#571	#504	#546
Internal Link Dist (ft)	966	802	965
Turn Bay Length (ft)			
Base Capacity (vph)	527	604	782
Starvation Cap Reductn	0	0	0
Spillback Cap Reductn	0	0	0
Storage Cap Reductn	0	0	0
Reduced v/c Ratio	1.07	0.88	0.71

Intersection Summary

~ Volume exceeds capacity, queue is theoretically infinite.
Queue shown is maximum after two cycles.

95th percentile volume exceeds capacity, queue may be longer.
Queue shown is maximum after two cycles.

HCM Signalized Intersection Capacity Analysis

16: Washington St & Brock St

6/3/2008



Movement	EBL	EBT	EBR	WBL	WBT	WBR	NBL	NBT	NBR	SBL	SBT	SBR
Lane Configurations		↑			↑			↕				
Ideal Flow (vphpl)	1900	1900	1900	1900	1900	1900	1900	1900	1900	1900	1900	1900
Total Lost time (s)		4.0			4.0			4.0				
Lane Util. Factor		1.00			1.00			1.00				
Frpb, ped/bikes		1.00			0.99			0.99				
Flpb, ped/bikes		1.00			1.00			1.00				
Frt		1.00			0.99			0.97				
Flt Protected		1.00			1.00			0.99				
Satd. Flow (prot)		1625			1565			1603				
Flt Permitted		0.79			1.00			0.99				
Satd. Flow (perm)		1282			1565			1603				
Volume (vph)	15	495	0	0	445	30	67	316	102	0	0	0
Peak-hour factor, PHF	0.80	0.91	0.25	0.25	0.91	0.72	0.90	0.90	0.77	0.25	0.25	0.25
Adj. Flow (vph)	19	544	0	0	489	42	74	351	132	0	0	0
RTOR Reduction (vph)	0	0	0	0	3	0	0	9	0	0	0	0
Lane Group Flow (vph)	0	563	0	0	528	0	0	548	0	0	0	0
Confl. Peds. (#/hr)	23					23			9			
Heavy Vehicles (%)	6%	5%	0%	0%	8%	0%	4%	1%	3%	0%	0%	0%
Turn Type	Perm							Perm				
Protected Phases		1			1				4			
Permitted Phases	1							4				
Actuated Green, G (s)		31.4			31.4			43.4				
Effective Green, g (s)		31.4			31.4			43.4				
Actuated g/C Ratio		0.35			0.35			0.48				
Clearance Time (s)		4.0			4.0			4.0				
Vehicle Extension (s)		3.0			3.0			3.0				
Lane Grp Cap (vph)		447			546			773				
v/s Ratio Prot					0.34							
v/s Ratio Perm		c0.44						0.34				
v/c Ratio		1.26			0.97			0.71				
Uniform Delay, d1		29.3			28.8			18.3				
Progression Factor		1.00			1.77			1.00				
Incremental Delay, d2		133.8			26.3			3.0				
Delay (s)		163.1			77.2			21.3				
Level of Service		F			E			C				
Approach Delay (s)		163.1			77.2			21.3				0.0
Approach LOS		F			E			C				A

Intersection Summary

HCM Average Control Delay	87.7	HCM Level of Service	F
HCM Volume to Capacity ratio	0.94		
Actuated Cycle Length (s)	90.0	Sum of lost time (s)	15.2
Intersection Capacity Utilization	78.7%	ICU Level of Service	D
Analysis Period (min)	15		
c Critical Lane Group			

Queues

18: Commonwealth Ave & South St

6/3/2008



HCM Unsignalized Intersection Capacity Analysis

19: Commonwealth Ave & Foster St

6/3/2008

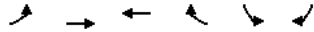

Movement	EBL	EBT	WBT	WBR	SBL	SBR
Lane Configurations		↑↑	↑↑			↗
Sign Control		Free	Free		Stop	
Grade		0%	0%		0%	
Volume (veh/h)	0	664	681	85	0	368
Peak Hour Factor	0.25	0.89	0.96	0.77	0.25	0.90
Hourly flow rate (vph)	0	746	709	110	0	409
Pedestrians		59			59	
Lane Width (ft)		12.0			12.0	
Walking Speed (ft/s)		4.0			4.0	
Percent Blockage		5			5	
Right turn flare (veh)						
Median type					None	
Median storage (veh)						
Upstream signal (ft)			504			
pX, platoon unblocked	0.92				0.92	0.92
vC, conflicting volume	879				1197	528
vC1, stage 1 conf vol						
vC2, stage 2 conf vol						
vCu, unblocked vol	783				1128	402
tC, single (s)	4.1				6.8	6.9
tC, 2 stage (s)						
tF (s)	2.2				3.5	3.3
p0 queue free %	100				100	18
cM capacity (veh/h)	739				176	500

Direction, Lane #	EB 1	EB 2	WB 1	WB 2	SB 1
Volume Total	373	373	473	347	409
Volume Left	0	0	0	0	0
Volume Right	0	0	0	110	409
cSH	1700	1700	1700	1700	500
Volume to Capacity	0.22	0.22	0.28	0.20	0.82
Queue Length 95th (ft)	0	0	0	0	198
Control Delay (s)	0.0	0.0	0.0	0.0	36.9
Lane LOS					E
Approach Delay (s)	0.0		0.0		36.9
Approach LOS					E

Intersection Summary				
Average Delay		7.6		
Intersection Capacity Utilization	60.8%		ICU Level of Service	B
Analysis Period (min)	15			

Queues

20: Washington St & Foster St

6/3/2008

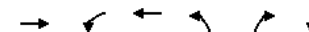

Lane Group	EBT	WBL	WBT	NBL	NBR	SBT
Lane Group Flow (vph)	681	291	378	119	236	174
v/c Ratio	1.19	0.53	0.71	0.70	1.00	0.59
Control Delay	111.3	21.4	30.9	41.0	67.5	35.1
Queue Delay	0.0	0.0	0.0	0.0	0.0	0.0
Total Delay	111.3	21.4	30.9	41.0	67.5	35.1
Queue Length 50th (ft)	~421	126	153	64	0	91
Queue Length 95th (ft) m#452	m101	m161	105	#126	132	
Internal Link Dist (ft)	802		985			367
Turn Bay Length (ft)		75			80	
Base Capacity (vph)	572	551	533	224	236	390
Starvation Cap Reductn	0	0	0	0	0	0
Spillback Cap Reductn	0	0	0	0	0	0
Storage Cap Reductn	0	0	0	0	0	0
Reduced v/c Ratio	1.19	0.53	0.71	0.53	1.00	0.45

Intersection Summary	
~	Volume exceeds capacity, queue is theoretically infinite. Queue shown is maximum after two cycles.
#	95th percentile volume exceeds capacity, queue may be longer. Queue shown is maximum after two cycles.
m	Volume for 95th percentile queue is metered by upstream signal.



↗ → ← ↖ ↘ ↙



HCM Unsignalized Intersection Capacity Analysis

33: Beacon St & Reservoir Rd

6/3/2008



Movement	EBT	EBR	WBL	WBT	NBL	NBR
Lane Configurations	↑			↑	↓	↓
Sign Control	Free		Free		Stop	
Grade	0%		0%		0%	
Volume (veh/h)	825	0	0	695	15	266
Peak Hour Factor	0.96	0.25	0.25	0.83	0.70	0.82
Hourly flow rate (vph)	859	0	0	837	21	324
Pedestrians	6		8			
Lane Width (ft)	12.0		12.0			
Walking Speed (ft/s)	4.0		4.0			
Percent Blockage	0		1			
Right turn flare (veh)						
Median type	None					
Median storage (veh)						
Upstream signal (ft)						
pX, platoon unblocked						
vC, conflicting volume			859		1703	867
vC1, stage 1 conf vol						
vC2, stage 2 conf vol						
vCu, unblocked vol			859		1703	867
tC, single (s)			4.1		6.4	6.2
tC, 2 stage (s)						
tF (s)			2.2		3.5	3.3
p0 queue free %			100		79	8
cM capacity (veh/h)			790		101	353

Direction, Lane #	EB 1	WB 1	NB 1
Volume Total	859	837	346
Volume Left	0	0	21
Volume Right	0	0	324
cSH	1700	1700	306
Volume to Capacity	0.51	0.49	1.13
Queue Length 95th (ft)	0	0	354
Control Delay (s)	0.0	0.0	129.0
Lane LOS	F		
Approach Delay (s)	0.0	0.0	129.0
Approach LOS	F		

Intersection Summary		
Average Delay	21.8	
Intersection Capacity Utilization	74.9%	ICU Level of F
0653		

HCM Signalized Intersection Capacity Analysis

35: Beacon St & College Rd

6/3/2008

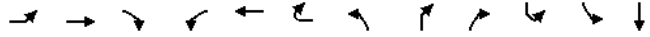

Movement	EBL	EBT	EBR	WBL	WBT	WBR2	NBL	NBR	NBR2	SBL2	SBL	SBT
Lane Configurations	↔	↔		↔	↔		↔	↔		↔	↔	↔
Ideal Flow (vphpl)	1900	1900	1900	1900	1900	1900	1900	1900	1900	1900	1900	1900
Lane Width	11	12	12	12	12	12	10	12	12	12	12	12
Total Lost time (s)	4.0	4.0		4.0	4.0		4.0	4.0				4.0
Lane Util. Factor	1.00	1.00		1.00	1.00		1.00	1.00				0.95
Frt	1.00	0.98		1.00	0.98		1.00	0.85				1.00
Flt Protected	0.95	1.00		0.95	1.00		0.95	1.00				0.98
Satd. Flow (prot)	1555	1652		1593	1656		1516	1420				3113
Flt Permitted	0.36	1.00		0.10	1.00		0.36	1.00				0.98
Satd. Flow (perm)	583	1652		166	1656		582	1420				3113
Volume (vph)	149	740	80	203	471	37	115	140	74	5	100	200
Peak-hour factor, PHF	0.91	0.96	0.84	0.81	0.78	0.52	0.79	0.84	0.71	0.62	0.80	0.78
Adj. Flow (vph)	164	771	95	251	604	71	146	167	104	8	125	256
RTOR Reduction (vph)	0	5	0	0	4	0	0	24	0	0	0	0
Lane Group Flow (vph)	164	861	0	251	671	0	146	247	0	0	0	389
Heavy Vehicles (%)	1%	2%	0%	2%	1%	7%	0%	2%	3%	0%	2%	3%
Turn Type	Perm		D,P+P			D,Pm	NA				Perm	
Protected Phases		3		2	2 3							1
Permitted Phases	3			3			1				1	
Actuated Green, G (s)	39.5	39.5		47.6	50.6		15.2	0.0				15.2
Effective Green, g (s)	40.5	40.5		47.6	51.6		16.2	0.0				16.2
Actuated g/C Ratio	0.47	0.47		0.56	0.60		0.19	0.00				0.19
Clearance Time (s)	5.0	5.0		3.0			5.0					5.0
Vehicle Extension (s)	3.0	3.0		3.0			3.0					3.0
Lane Grp Cap (vph)	276	783		211	1001		110	0				591
v/s Ratio Prot		0.52		c0.10	0.41							
v/s Ratio Perm	0.28			c0.57			c0.25					0.12
v/c Ratio	0.59	1.10		1.19	0.67		1.33	no cap				0.66
Uniform Delay, d1	16.4	22.5		23.2	11.2		34.6	Error				32.0
Progression Factor	1.00	1.00		1.00	1.00		1.00					1.00
Incremental Delay, d2	3.4	63.0		122.6	1.8		196.9	Error				2.7
Delay (s)	19.8	85.5		145.8	13.0		231.5	Error				34.7
Level of Service	B	F		F	B		F	F				C
Approach Delay (s)		75.0			49.0							32.4
Approach LOS		E			D							C

Intersection Summary

HCM Average Control Delay	Error	HCM Level of Service	F
HCM Volume to Capacity ratio	1.07		
Actuated Cycle Length (s)	85.4	Sum of lost time (s)	12.0
Intersection Capacity Utilization	91.1%	ICU Level of Service	F
Analysis Period (min)	15		
c Critical Lane Group			

HCM Signalized Intersection Capacity Analysis

35: Beacon St & College Rd

6/3/2008



Movement	SBR	SBT
Lane Configurations	↔	↔
Ideal Flow (vphpl)	1900	
Lane Width	12	
Total Lost time (s)	4.0	
Lane Util. Factor	1.00	
Frt	0.85	
Flt Protected	1.00	
Satd. Flow (prot)	1264	
Flt Permitted	1.00	
Satd. Flow (perm)	1264	
Volume (vph)	15	
Peak-hour factor, PHF	0.54	
Adj. Flow (vph)	28	
RTOR Reduction (vph)	0	
Lane Group Flow (vph)	28	
Heavy Vehicles (%)	15%	
Turn Type	Free	
Protected Phases		
Permitted Phases	Free	
Actuated Green, G (s)	85.4	
Effective Green, g (s)	85.4	
Actuated g/C Ratio	1.00	
Clearance Time (s)	5.0	
Vehicle Extension (s)		
Lane Grp Cap (vph)	1264	
v/s Ratio Prot		
v/s Ratio Perm	c0.02	
v/c Ratio	0.02	
Uniform Delay, d1	0.0	
Progression Factor	1.00	
Incremental Delay, d2	0.0	
Delay (s)	0.0	
Level of Service	A	
Approach Delay (s)		
Approach LOS		

Intersection Summary

HCM Average Control Delay	Error	HCM Level of Service	F
HCM Volume to Capacity ratio	1.07		
Actuated Cycle Length (s)	85.4	Sum of lost time (s)	12.0
Intersection Capacity Utilization	91.1%	ICU Level of Service	F
Analysis Period (min)	15		
c Critical Lane Group			

HCM Unsignalized Intersection Capacity Analysis

38: Commonwealth Ave & Mt Alvernia Road

6/3/2008



Movement	EBL	EBT	EBR	WBL	WBT	WBR	NBL	NBT	NBR	SBL	SBT	SBR
Lane Configurations	↕			↕			↕			↕		
Sign Control	Free			Free			Stop			Stop		
Grade	0%			0%			0%			0%		
Volume (veh/h)	35	786	5	55	566	10	27	15	264	35	5	20
Peak Hour Factor	0.46	0.83	0.35	0.83	0.91	0.40	0.71	0.69	0.94	0.65	0.25	0.59
Hourly flow rate (vph)	76	947	14	66	622	25	38	22	281	54	20	34
Pedestrians	9			9			10					
Lane Width (ft)	12.0			12.0			14.0					
Walking Speed (ft/s)	4.0			4.0			4.0					
Percent Blockage	1			1			1					
Right turn flare (veh)												
Median type							None					None
Median storage (veh)												
Upstream signal (ft)												
pX, platoon unblocked												
vC, conflicting volume	647			971			1936 1896			973 2174 1890		643
vC1, stage 1 conf vol												
vC2, stage 2 conf vol												
vCu, unblocked vol	647			971			1936 1896			973 2174 1890		643
tC, single (s)	4.1			4.1			7.2 6.5			6.2 7.1 6.5		6.2
tC, 2 stage (s)												
tF (s)	2.2			2.2			3.6 4.0			3.3 3.5 4.0		3.3
p0 queue free %	92			90			0 63			7 0 66		93
cM capacity (veh/h)	948			695			27 58			301 1 58		464

Direction, Lane #	EB 1	WB 1	NB 1	SB 1
Volume Total	1037	713	341	108
Volume Left	76	66	38	54
Volume Right	14	25	281	34
cSH	948	695	126	3
Volume to Capacity	0.08	0.10	2.71	40.47
Queue Length 95th (ft)	7	8	774	Err
Control Delay (s)	2.2	2.5	845.2	Err
Lane LOS	A	A	F	F
Approach Delay (s)	2.2	2.5	845.2	Err
Approach LOS			F	F

Intersection Summary			
Average Delay	622.7		
Intersection Capacity Utilization	85.3%	ICU Level of Service	E
Analysis Period (min)	15		

HCM Unsignalized Intersection Capacity Analysis

41: Rogers Park & Foster St

6/3/2008



Movement	EBL	EBR	NBL	NBT	SBT	SBR
Lane Configurations	↕			↕	↕	
Sign Control	Stop			Free	Free	
Grade	0%			0%	0%	
Volume (veh/h)	120	85	0	148	589	0
Peak Hour Factor	0.83	0.94	0.25	0.80	0.96	0.25
Pedestrians				29	30	
Lane Width (ft)				12.0	12.0	
Walking Speed (ft/s)				4.0	4.0	
Percent Blockage				2	2	
Right turn flare (veh)						
Median type				None		
Median storage (veh)						
Upstream signal (ft)						946
pX, platoon unblocked	0.92	0.92	0.92			
vC, conflicting volume	829	643	614			
vC1, stage 1 conf vol						
vC2, stage 2 conf vol						
vCu, unblocked vol	813	611	579			
tC, single (s)	6.4	6.2	4.1			
tC, 2 stage (s)						
tF (s)	3.5	3.3	2.2			
p0 queue free %	54	80	100			
cM capacity (veh/h)	313	443	922			

Direction, Lane #	EB 1	NB 1	SB 1
Volume Total	235	185	614
Volume Left	145	0	0
Volume Right	90	0	0
cSH	352	1700	1700
Volume to Capacity	0.67	0.11	0.36
Queue Length 95th (ft)	114	0	0
Control Delay (s)	33.5	0.0	0.0
Lane LOS	D		
Approach Delay (s)	33.5	0.0	0.0
Approach LOS	D		

Intersection Summary		
Average Delay	7.6	

HCM Unsignalized Intersection Capacity Analysis

46: Chestnut Hill Driveway & T. Moore

6/3/2008



Movement	WBL	WBR	NBT	NBR	SBL	SBT
Lane Configurations	↔	↔	↔	↔	↔	↔
Sign Control	Stop		Free			Free
Grade	0%		0%			0%
Volume (veh/h)	60	10	319	156	7	300
Peak Hour Factor	0.69	0.70	0.51	0.88	0.69	0.70
Hourly flow rate (vph)	87	14	625	177	10	429
Pedestrians						
Lane Width (ft)						
Walking Speed (ft/s)						
Percent Blockage						
Right turn flare (veh)						
Median type	None					
Median storage (veh)						
Upstream signal (ft)						
pX, platoon unblocked						
vC,545588 317.471 refBT0 -6.3116 6.3116 0 361T.i scNone						

HCM Unsignalized Intersection Capacity Analysis

51: Campanella Way & Fr. Herlihy Drive

6/3/2008



Movement	EBL	EBT	WBT	WBR	SBL	SBR
Lane Configurations		↑	↑		↓	↓
Sign Control		Stop	Yield		Stop	
Volume (vph)	0	1	181	0	107	138
Peak Hour Factor	0.25	0.71	0.70	0.25	0.89	0.83
Hourly flow rate (vph)	0	1	259	0	120	166
Direction, Lane #	EB 1	WB 1	SB 1	SB 2		
Volume Total (vph)	1	259	120	166		
Volume Left (vph)	0	0	120	0		
Volume Right (vph)	0	0	0	166		
Hadj (s)	0.00	0.05	0.72	-0.65		
Departure Headway (s)	4.9	4.6	5.9	4.5		
Degree Utilization, x	0.00	0.33	0.20	0.21		
Capacity (veh/h)	676	741	591	766		
Control Delay (s)	7.9	9.9	9.1	7.5		
Approach Delay (s)	7.9	9.9	8.1			
Approach LOS	A	A	A			
Intersection Summary						
Delay	9.0					
HCM Level of Service	A					
Intersection Capacity Utilization	28.4%		ICU Level of Service	A		
Analysis Period (min)	15					

Queues

2: Commonwealth Ave & Lake Street

6/3/2008



↓



HCM Signalized Intersection Capacity Analysis

3: Commonwealth Ave & Chestnut Hill

6/3/2008

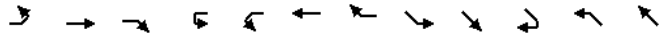

Movement	EBL	EBT	EBR	WBU	WBL	WBT	WBR	SEL	SET	SER	NWL	NWT
Lane Configurations	↔	↕	↔	↔	↕	↕	↔	↔	↕	↕	↔	↔
Ideal Flow (vphpl)	1900	1900	1900	1900	1900	1900	1900	1900	1900	1900	1900	1900
Lane Width	12	12	12	12	12	10	10	12	12	12	12	12
Total Lost time (s)	4.0	4.0			4.0	4.0			4.0	4.0	4.0	4.0
Lane Util. Factor	1.00	0.95			1.00	0.95			0.95	1.00	1.00	1.00
Frt	1.00	0.94			1.00	0.98			1.00	0.85	1.00	0.95
Flt Protected	0.95	1.00			0.95	1.00			1.00	1.00	0.95	1.00
Satd. Flow (prot)	1624	2987			1609	2909			3148	1454	1624	1585
Flt Permitted	0.27	1.00			0.15	1.00			0.51	1.00	0.20	1.00
Satd. Flow (perm)	459	2987			259	2909			1605	1454	345	1585
Volume (vph)	117	363	250	5	220	377	25	45	490	30	205	415
Peak-hour factor, PHF	0.80	0.90	0.89	0.92	0.91	0.87	0.50	0.75	0.91	0.72	0.88	0.86
Adj. Flow (vph)	146	403	281	5	242	433	50	60	538	42	233	483
RTOR Reduction (vph)	0	101	0	0	0	7	0	0	0	12	0	14
Lane Group Flow (vph)	146	583	0	0	247	476	0	0	598	30	233	702
Heavy Vehicles (%)	0%	0%	5%	0%	1%	2%	8%	0%	3%	0%	0%	2%
Turn Type	pm+pt			pm+pt			Perm		Perm	D.P+P		
Protected Phases	9	1			9	1			3		4	3 4
Permitted Phases	1				1		3		3		3	
Actuated Green, G (s)	45.0	26.2			45.0	26.2			29.0	29.0	44.0	48.0
Effective Green, g (s)	43.0	26.2			43.0	26.2			29.0	29.0	44.0	48.0
Actuated g/C Ratio	0.36	0.22			0.36	0.22			0.24	0.24	0.37	0.40
Clearance Time (s)	2.0	4.0			2.0	4.0			4.0	4.0	4.0	4.0
Vehicle Extension (s)	3.0	3.0			3.0	3.0			3.0	3.0	3.0	3.0
Lane Grp Cap (vph)	328	652			282	635			388	351	286	634
v/s Ratio Prot	0.06	c0.20			c0.12	0.16					0.10	c0.44
v/s Ratio Perm	0.10				0.19				c0.37	0.02	0.20	
v/c Ratio	0.45	0.89			0.88	0.75			1.54	0.09	0.81	1.11
Uniform Delay, d1	27.8	45.6			31.3	43.8			45.5	35.2	42.7	36.0
Progression Factor	1.00	1.00			1.00	1.00			1.00	1.00	1.00	1.00
Incremental Delay, d2	1.0	17.2			24.7	7.9			256.1	0.5	16.1	68.6
Delay (s)	28.8	62.7			56.0	51.8			301.6	35.7	58.8	104.6
Level of Service	C	E			E	D			F	D	E	F
Approach Delay (s)		56.8				53.2			284.2			93.4
Approach LOS		E				D			F			F

Intersection Summary

HCM Average Control Delay	113.2	HCM Level of Service	F
HCM Volume to Capacity ratio	1.12		
Actuated Cycle Length (s)	120.0	Sum of lost time (s)	29.0
Intersection Capacity Utilization	101.9%	ICU Level of Service	G
Analysis Period (min)	15		
c Critical Lane Group			

HCM Signalized Intersection Capacity Analysis

3: Commonwealth Ave & Chestnut Hill

6/3/2008



Movement	NWR
Lane Configurations	↔
Ideal Flow (vphpl)	1900
Lane Width	12
Total Lost time (s)	
Lane Util. Factor	
Frt	
Flt Protected	
Satd. Flow (prot)	
Flt Permitted	
Satd. Flow (perm)	
Volume (vph)	205
Peak-hour factor, PHF	0.88
Adj. Flow (vph)	233
RTOR Reduction (vph)	0
Lane Group Flow (vph)	0
Heavy Vehicles (%)	4%
Turn Type	
Protected Phases	
Permitted Phases	
Actuated Green, G (s)	
Effective Green, g (s)	
Actuated g/C Ratio	
Clearance Time (s)	
Vehicle Extension (s)	
Lane Grp Cap (vph)	
v/s Ratio Prot	
v/s Ratio Perm	
v/c Ratio	
Uniform Delay, d1	
Progression Factor	
Incremental Delay, d2	
Delay (s)	
Level of Service	
Approach Delay (s)	
Approach LOS	

Intersection Summary

HCM Average Control Delay		HCM Level of Service	
HCM Volume to Capacity ratio			
Actuated Cycle Length (s)		Sum of lost time (s)	
Intersection Capacity Utilization		ICU Level of Service	
Analysis Period (min)			
c Critical Lane Group			



HCM Unsignalized Intersection Capacity Analysis

8: Beacon St & Gate House Road

6/3/2008



HCM Signalized Intersection Capacity Analysis

13: Washington St & Market Street

6/3/2008



Movement	EBL	EBT	EBR	WBL	WBT	WBR	NBL	NBT	NBR	SBL	SBT	SBR
Lane Configurations		↔		↔	↔		↔	↔		↔	↔	↔
Ideal Flow (vphpl)	1900	1900	1900	1900	1900	1900	1900	1900	1900	1900	1900	1900
Lane Width	10	11	16	10	11	16	16	16	16	12	12	10
Total Lost time (s)		4.0		4.0	4.0		4.0	4.0		4.0	4.0	4.0
Lane Util. Factor		1.00		1.00	1.00		1.00	1.00		1.00	1.00	1.00
Frt		0.97		1.00	0.96		1.00	0.98		1.00	1.00	0.85
Flt Protected		0.99		0.95	1.00		0.95	1.00		0.95	1.00	1.00
Satd. Flow (prot)		1375		1189	1230		1823	1871		1421	1496	1187
Flt Permitted		0.11		0.27	1.00		0.27	1.00		0.41	1.00	1.00

Queues
16: Washington St & Brock St

6/3/2008

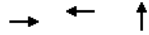

Lane Group	EBT	WBT	NBT
Lane Group Flow (vph)	683	564	599
v/c Ratio	1.89	0.85	0.78
Control Delay	434.9	50.9	32.4
Queue Delay	0.0	0.0	0.0
Total Delay	434.9	50.9	32.4
Queue Length 50th (ft)	~670	302	278
Queue Length 95th (ft)	#889 m#402	#402	#659
Internal Link Dist (ft)	966	802	965
Turn Bay Length (ft)			
Base Capacity (vph)	361	662	767
Starvation Cap Reductn	0	0	0
Spillback Cap Reductn	0	0	0
Storage Cap Reductn	0	0	0
Reduced v/c Ratio	1.89	0.85	0.78

Intersection Summary

- ~ Volume exceeds capacity, queue is theoretically infinite.
Queue shown is maximum after two cycles.
- # 95th percentile volume exceeds capacity, queue may be longer.
Queue shown is maximum after two cycles.
- m Volume for 95th percentile queue is metered by upstream signal.

HCM Signalized Intersection Capacity Analysis
16: Washington St & Brock St

6/3/2008



Movement	EBL	EBT	EBR	WBL	WBT	WBR	NBL	NBT	NBR	SBL	SBT	SBR
Ideal Flow (vphpl)	1900	1900	1900	1900	1900	1900	1900	1900	1900	1900	1900	1900
Total Lost time (s)		4.0			4.0			4.0				

Queues

18: Commonwealth Ave & South St

6/3/2008



Lane Group	EBT	WBT	SWL
Lane Group Flow (vph)	862	709	233
w/c Ratio	1.16	0.42	0.42
Control Delay	107.5	12.4	8.2

HCM Unsignalized Intersection Capacity Analysis

19: Commonwealth Ave & Foster St

6/3/2008

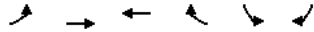

Movement	EBL	EBT	WBT	WBR	SBL	SBR
Lane Configurations		↑↑	↑↑			↗
Sign Control		Free	Free		Stop	
Grade		0%	0%		0%	
Volume (veh/h)	0	694	749	55	0	386
Peak Hour Factor	0.25	0.83	0.94	0.74	0.25	0.89
Hourly flow rate (vph)	0	836	797	74	0	434
Pedestrians					65	
Lane Width (ft)					12.0	
Walking Speed (ft/s)					4.0	
Percent Blockage					5	
Right turn flare (veh)						
Median type					None	
Median storage (veh)						
Upstream signal (ft)			504			
pX, platoon unblocked	0.89				0.89	0.89
vC, conflicting volume	936				1317	501
vC1, stage 1 conf vol						
vC2, stage 2 conf vol						
vCu, unblocked vol	804				1232	315
tC, single (s)	4.1				6.8	6.9
tC, 2 stage (s)						
tF (s)	2.2				3.5	3.3
p0 queue free %	100				100	25
cM capacity (veh/h)	697				145	578

Direction, Lane #	EB 1	EB 2	WB 1	WB 2	SB 1
Volume Total	418	418	531	340	434
Volume Left	0	0	0	0	0
Volume Right	0	0	0	74	434
cSH	1700	1700	1700	1700	578
Volume to Capacity	0.25	0.25	0.31	0.20	0.75
Queue Length 95th (ft)	0	0	0	0	165
Control Delay (s)	0.0	0.0	0.0	0.0	27.6
Lane LOS					D
Approach Delay (s)	0.0		0.0		27.6
Approach LOS					D

Intersection Summary			
Average Delay		5.6	
Intersection Capacity Utilization	58.5%	ICU Level of Service	B
Analysis Period (min)	15		

Queues

20: Washington St & Foster St

6/3/2008

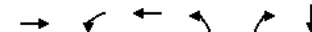

Lane Group	EBT	WBL	WBT	NBL	NBR	SBT
Lane Group Flow (vph)	737	315	452	78	218	274
v/c Ratio	1.34	0.59	0.83	0.48	1.00	0.79
Control Delay	177.5	29.9	33.2	37.3	69.8	41.9
Queue Delay	0.0	0.0	0.0	0.0	0.0	0.0
Total Delay	177.5	29.9	33.2	37.3	69.8	41.9
Queue Length 50th (ft)	~588	123	258	44	0	166
Queue Length 95th (ft)	m137	m168	m220	82	#136	222
Internal Link Dist (ft)	802		985			367
Turn Bay Length (ft)		75			80	
Base Capacity (vph)	552	536	546	206	218	442
Starvation Cap Reductn	0	0	0	0	0	0
Spillback Cap Reductn	0	0	0	0	0	0
Storage Cap Reductn	0	0	0	0	0	0
Reduced v/c Ratio	1.34	0.59	0.83	0.38	1.00	0.62

Intersection Summary	
~	Volume exceeds capacity, queue is theoretically infinite. Queue shown is maximum after two cycles.
#	95th percentile volume exceeds capacity, queue may be longer. Queue shown is maximum after two cycles.
m	Volume for 95th percentile queue is metered by upstream signal.

HCM Signalized Intersection Capacity Analysis

20: Washington St & Foster St

6/3/2008



Movement	EBL	EBT	EBR	WBL	WBT	WBR	NBL	NBT	NBR	SBL	SBT	SBR
Lane Configurations		↕		↕	↕		↕		↕		↕	↕
Ideal Flow (vphpl)	1900	1900	1900	1900	1900	1900	1900	1900	1900	1900	1900	1900
Lane Width	12	12	10	10	12	12	10	10	10	12	10	10
Total Lost time (s)		4.0		4.0	4.0		4.0		4.0		4.0	
Lane Util. Factor		1.00		1.00	1.00		1.00		1.00		1.00	
Fr _t		0.96		1.00	1.00		1.00		0.85		0.98	
Fl _t Protected		1.00		0.95	1.00		0.95		1.00		0.99	

HCM Unsignalized Intersection Capacity Analysis
26: Commonwealth Ave & Campus Driveway

6/3/2008

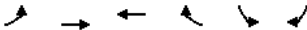

HCM Unsignalized Intersection Capacity Analysis

33: Beacon St & Reservoir Rd

6/3/2008















Movement	EBT	EBR	WBL	WBT	NBL	NBR
Lane Configurations	↑			↑	↘	↘
Sign Control	Free		Free		Stop	
Grade	0%		0%		0%	
Volume (veh/h)	515	0	0	1121	10	198
Peak Hour Factor	0.88	0.25	0.25	0.93	0.39	0.89
Hourly flow rate (vph)	585	0	0	1205	26	222
Pedestrians	10		7			
Lane Width (ft)	12.0		12.0			
Walking Speed (ft/s)	4.0		4.0			
Percent Blockage	1		1			
Right turn flare (veh)						
Median type	None					
Median storage (veh)						
Upstream signal (ft)						
pX, platoon unblocked						
vC, conflicting volume			585		1801	592
vC1, stage 1 conf vol						
vC2, stage 2 conf vol						
vCu, unblocked vol			585		1801	592
tC, single (s)			4.1		6.4	6.2
tC, 2 stage (s)						
tF (s)			2.2		3.5	3.3
p0 queue free %			100		71	56

HCM Signalized Intersection Capacity Analysis

35: Beacon St & College Rd

6/3/2008

													
Movement	EBL	EBT	EBR	WBL	WBT	WBR2	NBL	NBR	NBR2	SBL2	SBL	SBT	

HCM Unsignalized Intersection Capacity Analysis

38: Commonwealth Ave & Mt Alvernia Road

6/3/2008



Movement	EBL	EBT	EBR	WBL	WBT	WBR	NBL	NBT	NBR	SBL	SBT	SBR
Lane Configurations	↕			↕			↕			↕		
Sign Control	Free			Free			Stop			Stop		
Grade	0%			0%			0%			0%		
Volume (veh/h)	5	579	5	95	700	5	89	15	244	10	5	20
Peak Hour Factor	0.47	0.89	0.40	0.84	0.86	0.62	0.79	0.83	0.92	0.45	0.67	0.62
Hourly flow rate (vph)	11	651	12	113	814	8	113	18	265	22	7	32
Pedestrians	63			51			46			4		
Lane Width (ft)	12.0			12.0			14.0			12.0		
Walking Speed (ft/s)	4.0			4.0			4.0			4.0		
Percent Blockage	5			4			4			0		
Right turn flare (veh)												
Median type	None						None					
Median storage (veh)												
Upstream signal (ft)												
pX, platoon unblocked												
vC, conflicting volume	826		709		1867		1776		754		2052	
vC1, stage 1 conf vol												
vC2, stage 2 conf vol												
vCu, unblocked vol	826		709		1867		1776		754		2052	
tC, single (s)	4.1		4.1		7.1		6.5		6.3		7.1	
tC, 2 stage (s)												
tF (s)	2.2		2.2		3.5		4.0		3.4		3.5	
p0 queue free %	99		87		0		73		28		0	
cM capacity (veh/h)	811		850		36		68		367		8	

Direction, Lane #	EB 1	WB 1	NB 1	SB 1
Volume Total	674	935	396	62
Volume Left	11	113	113	22
Volume Right	12	8	265	32
cSH	811	850	96	20
Volume to Capacity	0.01	0.13	4.11	3.15
Queue Length 95th (ft)	1	11	Err	Err
Control Delay (s)	0.4	3.4	Err	Err
Lane LOS	A	A	F	F
Approach Delay (s)	0.4	3.4	Err	Err
Approach LOS			F	F

Intersection Summary			
Average Delay	2217.0		
Intersection Capacity Utilization	123.9%	ICU Level of Service	H
Analysis Period (min)	15		

HCM Unsignalized Intersection Capacity Analysis

41: Rogers Park & Foster St

6/3/2008



Movement	EBL	EBR	NBL	NBT	SBT	SBR
Lane Configurations	↕			↕	↕	
Sign Control	Stop			Free	Free	
Grade	0%			0%		0%
Volume (veh/h)	70	85	0	162	628	0
Peak Hour Factor	0.76	0.94	0.25	0.90	0.90	0.25
Hourly flow rate (vph)	92	90	0	180	698	0
Pedestrians				38		46
Lane Width (ft)				12.0		12.0
Walking Speed (ft/s)				4.0		4.0
Percent Blockage				3		4
Right turn flare (veh)						
Median type	None					
Median storage (veh)						
Upstream signal (ft)	946					
pX, platoon unblocked	0.88	0.88	0.88			
vC, conflicting volume	924	736	698			
vC1, stage 1 conf vol						
vC2, stage 2 conf vol						
vCu, unblocked vol	914	700	657			
tC, single (s)	6.4	6.2	4.1			
tC, 2 stage (s)						
tF (s)	3.5	3.3	2.2			
p0 queue free %	64	76	100			
cM capacity (veh/h)	256	376	829			

Direction, Lane #	EB 1	NB 1	SB 1
Volume Total	183	180	698
Volume Left	92	0	0
Volume Right	90	0	0
cSH	304	1700	1700
Volume to Capacity	0.60	0.11	0.41
Queue Length 95th (ft)	91	0	0
Control Delay (s)	33.1	0.0	0.0
Lane LOS	D		
Approach Delay (s)	33.1	0.0	0.0
Approach LOS	D		

Intersection Summary			
Average Delay	5.7		
Intersection Capacity Utilization	56.3%	ICU Level of Service	B
Analysis Period (min)	15		

HCM Unsignalized Intersection Capacity Analysis

46: Chestnut Hill Driveway & T. Moore

6/3/2008



Movement	WBL	WBR	NBT	NBR	SBL	SBT
Lane Configurations	W	R	T	R	L	R
Sign Control	Stop		Free		Free	
Grade	0%		0%		0%	
Volume (veh/h)	55	15	279	92	19	422
Peak Hour Factor	0.69	0.70	0.51	0.88	0.69	0.70
Hourly flow rate (vph)	80	21	547	105	28	603
Pedestrians						
Lane Width (ft)						
Walking Speed (ft/s)						
Percent Blockage						
Right turn flare (veh)						
Median type	None					
Median storage (veh)						
Upstream signal (ft)						
pX, platoon unblocked						
vC, conflicting volume	1257	599			652	
vC1, stage 1 conf vol						
vC2, stage 2 conf vol						
vCu, unblocked vol	1257	599			652	
tC, single (s)	6.9	6.2			4.2	
tC, 2 stage (s)						
tF (s)	3.9	3.3			2.3	
p0 queue free %	46	96			97	
cM capacity (veh/h)	148	503			876	
Direction, Lane #	WB 1	NB 1	SB 1			
Volume Total	101	652	630			
Volume Left	80	0	28			
Volume Right	21	105	0			
cSH	174	1700	876			
Volume to Capacity	0.58	0.38	0.03			
Queue Length 95th (ft)	78	0	2			

HCM Unsignalized Intersection Capacity Analysis

51: Campanella Way & Fr. Herlihy Drive

6/3/2008

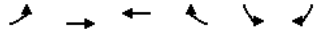

Movement	EBL	EBT	WBT	WBR	SBL	SBR
Lane Configurations		↑	↑		↓	↓
Sign Control		Stop	Yield		Stop	
Volume (vph)	0	45	178	0	66	73
Peak Hour Factor	0.25	0.61	0.70	0.25	0.73	0.82
Hourly flow rate (vph)	0	74	254	0	90	89
Direction, Lane #	EB 1	WB 1	SB 1	SB 2		
Volume Total (vph)	74	254	90	89		
Volume Left (vph)	0	0	90	0		
Volume Right (vph)	0	0	0	89		
Hadj (s)	0.00	0.09	0.77	-0.63		
Departure Headway (s)	4.7	4.5	6.1	4.6		
Degree Utilization, x	0.10	0.32	0.15	0.11		
Capacity (veh/h)	734	760	566	728		
Control Delay (s)	8p152.5115		0.11			

Queues
2: Commonwealth Ave & Lake Street

6/3/2008

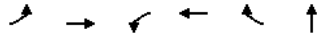

Lane Group	EBL	EBT	WBL	WBT	WBR	NBT
Lane Group Flow (vph)	290	1021	382	622	120	473
v/c Ratio	1.07	0.90	1.08	0.82	0.31	1.07
Control Delay	118.8	42.5	111.8	49.8	8.5	96.7
Queue Delay	0.0	0.0	0.0	0.0	0.0	0.0
Total Delay	118.8	42.5	111.8	49.8	8.5	96.7
Queue Length 50th (ft)	~229	340	~305	220	0	~177
Queue Length 95th (ft)	#399	#411	#459	#305	40	#221
Internal Link Dist (ft)		1877		667		286
Turn Bay Length (ft)	200		300		200	
Base Capacity (vph)	271	1149	353	758	391	441
Starvation Cap Reductn	0	0	0	0	0	0
Spillback Cap Reductn	0	0	0	0	0	0
Storage Cap Reductn	0	0	0	0	0	0
Reduced v/c Ratio	1.07	0.89	1.08	0.82	0.31	1.07

Intersection Summary

~ Volume exceeds capacity, queue is theoretically infinite.
Queue shown is maximum after two cycles.

95th percentile volume exceeds capacity, queue may be longer.
Queue shown is maximum after two cycles.

HCM Signalized Intersection Capacity Analysis
2: Commonwealth Ave & Lake Street

6/3/2008

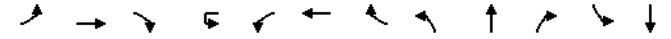

Movement	EBL	EBT	EBR	WBU	WBL	WBT	WBR	NBL	NBT	NBR	SBL	SBT
Lane Configurations	↖	↗	↘	↙	↖	↗	↘	↙	↖	↗	↘	↙
Ideal Flow (vphpl)	1900	1900	1900	1900	1900	1900	1900	1900	1000	1900	1900	1900
Lane Width	11	12	12	12	11	12	12	10	10	10	12	12
Total Lost time (s)	4.0	4.0			4.0	4.0	4.0		4.0			
Lane Util. Factor	1.00	0.95			1.00	0.95	1.00		0.95			
Frbp, ped/bikes	1.00	1.00			1.00	1.00	0.91		1.00			

HCM Signalized Intersection Capacity Analysis
2: Commonwealth Ave & Lake Street

6/3/2008



↙



Queues
2: Commonwealth Ave & Lake Street

6/3/2008



Lane Group	EBL	EBT	WBL	WBT	WBR	NBT
Lane Group Flow (vph)	290	1021	375	622	120	473
v/c Ratio	1.02	0.93	1.04	0.81	0.31	1.03
Control Delay	106.2	50.5	104.4	52.1	8.6	86.4
Queue Delay	0.0	0.0	0.0	0.0	0.0	0.0
Total Delay	106.2	50.5	104.4	52.1	8.6	86.4
Queue Length 50th (ft)	~233	385	~316	240	0	~187
Queue Length 95th (ft)	#413	#486	#472	311	41	#229
Internal Link Dist (ft)		1877		667		286
Turn Bay Length (ft)	200		300		200	
Base Capacity (vph)	285	1105	359	771	393	458
Starvation Cap Reductn	0	0	0	0	0	0
Spillback Cap Reductn	0	0	0	0	0	0
Storage Cap Reductn	0	0	0	0	0	0
Reduced v/c Ratio	1.02	0.92	1.04	0.81	0.31	1.03

Intersection Summary

~ Volume exceeds capacity, queue is theoretically infinite.
Queue shown is maximum after two cycles.

95th percentile volume exceeds capacity, queue may be longer.
Queue shown is maximum after two cycles.

HCM Signalized Intersection Capacity Analysis
2: Commonwealth Ave & Lake Street

6/3/2008

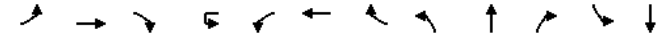

Movement	EBL	EBT	EBR	WBU	WBL	WBT	WBR	NBL	NBT	NBR	SBL	SBT
Lane Configurations	↔	↔↔			↔	↔↔	↔		↔↔			
Ideal Flow (vphpl)	1900	1900	1900	1900	1900	1900	1900	1900	1000	1900	1900	1900
Lane Width	11	12	12	12	11	12	12	10	10	10	12	12
Total Lost time (s)	4.0	4.0			4.0	4.0	4.0		4.0			
Lane Util. Factor	1.00	0.95			1.00	0.95	1.00		0.95			
Frpb, ped/bikes	1.00	1.00			1.00	1.00	0.90		1.00			
Flpb, ped/bikes	1.00	1.00			1.00	1.00	1.00		1.00			
Flt	1.00	0.96			1.00	1.00	0.85		0.95			
Flt Protected	0.95	1.00			0.95	1.00	1.00		0.99			
Satd. Flow (prot)	1555	3083			1482	3185	1250		1333			
Flt Permitted	0.95	1.00			0.95	1.00	1.00		0.99			
Satd. Flow (perm)	1555	3083			1482	3185	1250		1333			
Volume (vph)	264	671	215	1	322	578	102	63	181	95	0	0
Peak-hour factor, PHF	0.91	0.87	0.86	0.92	0.86	0.93	0.85	0.70	0.78	0.63	0.25	0.25
Adj. Flow (vph)	290	771	250	1	374	622	120	90	232	151	0	0
RTOR Reduction (vph)	0	26	0	0	0	0	91	0	46	0	0	0
Lane Group Flow (vph)	290	995	0	0	375	622	29	0	427	0	0	0

HCM Signalized Intersection Capacity Analysis
2: Commonwealth Ave & Lake Street

6/3/2008



Movement	SBR
Lane Configurations	
Ideal Flow (vphpl)	1900
Lane Width	12
Total Lost time (s)	
Lane Util. Factor	
Frbp, ped/bikes	
Fipb, ped/bikes	
Frt	
Flt Protected	
Satd. Flow (prot)	
Flt Permitted	
Satd. Flow (perm)	
Volume (vph)	0
Peak-hour factor, PHF	0.25
Adj. Flow (vph)	0
RTOR Reduction (vph)	0
Lane Group Flow (vph)	0
Confl. Peds. (#/hr)	
Heavy Vehicles (%)	0%
Turn Type	
Protected Phases	
Permitted Phases	
Actuated Green, G (s)	
Effective Green, g (s)	
Actuated g/C Ratio	
Clearance Time (s)	
Vehicle Extension (s)	
Lane Grp Cap (vph)	
v/s Ratio Prot	
v/s Ratio Perm	
v/c Ratio	
Uniform Delay, d1	
Progression Factor	
Incremental Delay, d2	
Delay (s)	
Level of Service	
Approach Delay (s)	
Approach LOS	
Intersection Summary	

Queues
26: Commonwealth Ave & Campus Driveway

6/3/2008



Lane Group	EBL	EBT	WBT	SBL
Lane Group Flow (vph)	104	746	1085	76
v/c Ratio	0.34	0.37	0.71	0.42
Control Delay	9.7	6.4	17.8	12.5
Queue Delay	0.0	0.0	0.0	0.0
Total Delay	9.7	6.4	17.8	12.5
Queue Length 50th (ft)	6	29	127	2
Queue Length 95th (ft)	61	170	#427	40
Internal Link Dist (ft)		667	961	372
Turn Bay Length (ft)	75			
Base Capacity (vph)	310	2021	1545	294
Starvation Cap Reductn	0	0	0	0
Spillback Cap Reductn	0	0	0	0
Storage Cap Reductn	0	0	0	0
Reduced v/c Ratio	0.34	0.37	0.70	0.26

Intersection Summary

95th percentile volume exceeds capacity, queue may be longer.
Queue shown is maximum after two cycles.

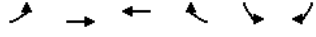

Movement	EBL	EBT	WBT	WBR	SBL	SBR
----------	-----	-----	-----	-----	-----	-----

Queues
2: Commonwealth Ave & Lake Street

6/3/2008



Lane Group	EBL	EBT	WBL	WBT	WBR	NBT
Lane Group Flow (vph)	190	854	401	798	192	653
v/c Ratio	0.98	0.95	1.10	1.03	0.51	1.07
Control Delay	117.6	64.8	123.2	88.4	16.3	93.9
Queue Delay	0.0	0.0	0.0	0.0	0.0	0.0
Total Delay	117.6	64.8	123.2	88.4	16.3	93.9
Queue Length 50th (ft)	162	365	~384	~378	28	~308
Queue Length 95th (ft)	#302	384	#515	#508	96	#384
Internal Link Dist (ft)		1877		667		202
Turn Bay Length (ft)	200		300		200	
Base Capacity (vph)	193	899	364	775	377	608
Starvation Cap Reductn	0	0	0	0	0	0
Spillback Cap Reductn	0	0	0	0	0	0
Storage Cap Reductn	0	0	0	0	0	0
Reduced v/c Ratio	0.98	0.95	1.10	1.03	0.51	1.07

Intersection Summary

~ Volume exceeds capacity, queue is theoretically infinite.
Queue shown is maximum after two cycles.

95th percentile volume exceeds capacity, queue may be longer.
Queue shown is maximum after two cycles.

HCM Signalized Intersection Capacity Analysis
2: Commonwealth Ave & Lake Street

6/3/2008

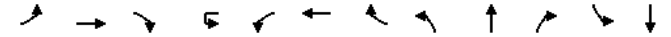

Movement	EBL	EBT	EBR	WBU	WBL	WBT	WBR	NBL	NBT	NBR	SBL	SBT
Lane Configurations												
Ideal Flow (vphpl)	1900	1900	1900	1900	1900	1900	1900	1900	1000	1900	1900	1900
Lane Width	11	12	12	12	11	12	12	10	10	10	12	12
Total Lost time (s)	4.0	4.0			4.0	4.0	4.0		4.0			
Lane Util. Factor	1.00	0.95			1.00	0.95	1.00		0.95			

HCM Signalized Intersection Capacity Analysis

2: Commonwealth Ave & Lake Street

6/3/2008



Movement	SBR
Lane Configurations	
Ideal Flow (vphpl)	1900
Lane Width	12
Total Lost time (s)	
Lane Util. Factor	
Frbp, ped/bikes	
Fipb, ped/bikes	
Frt	
Flt Protected	

HCM Signalized Intersection Capacity Analysis

26: Commonwealth Ave & Campus Driveway

6/3/2008

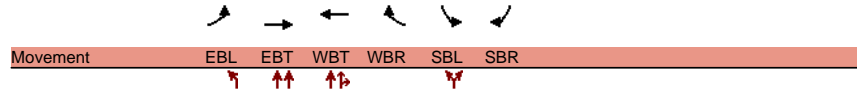

Queues

2: Commonwealth Ave & Lake Street

6/3/2008

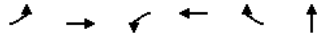

Lane Group	EBL	EBT	WBL	WBT	WBR	NBT
Lane Group Flow (vph)	290	1021	153	622	120	419
w/c Ratio	1.03	0.83	0.54	1.01	0.35	1.01
Control Delay	100.4	28.8	40.7	77.4	9.4	77.1
Queue Delay	0.0	0.0	0.0	0.0	0.0	0.0
Total Delay	100.4	28.8	40.7	77.4	9.4	77.1
Queue Length 50th (ft)	~181	251	79	~202	0	~120
Queue Length 95th (ft)	#337	316	135	#309	39	#172

Queues

26: Commonwealth Ave & Campus Driveway

6/3/2008

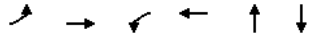

Lane Group	EBL	EBT	WBL	WBT	NBT	SBT
Lane Group Flow (vph)	157	708	180	912	42	76
w/c Ratio	0.58	0.28	0.48	0.39	0.23	0.41
Control Delay	21.6	5.4	14.5	6.1	25.4	17.6
Queue Delay	0.0	0.0	0.0	0.0	0.0	0.0
Total Delay	21.6	5.4	14.5	6.1	25.4	17.6
Queue Length 50th (ft)	20	34	20	48	15	14
Queue Length 95th (ft)	88	156	#186	223	46	54
Internal Link Dist (ft)		667		961	983	372
Turn Bay Length (ft)	75		75			
Base Capacity (vph)	272	2489	376	2322	305	284
Starvation Cap Reductn	0	0	0	0	0	0
Spillback Cap Reductn	0	0	0	0	0	0
Storage Cap Reductn	0	0	0	0	0	0

HCM Signalized Intersection Capacity Analysis

26: Commonwealth Ave & Campus Driveway

6/3/2008



Movement	SBR
Lane Configurations	
Ideal Flow (vphpl)	1900
Lane Width	12
Total Lost time (s)	
Lane Util. Factor	
Frt	
Flt Protected	

Queues

2: Commonwealth Ave & Lake Street

6/3/2008

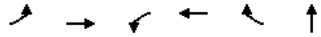

Lane Group	EBL	EBT	WBL	WBT	WBR	NBT
Lane Group Flow (vph)	190	854	163	798	192	621
v/c Ratio	0.91	0.90	0.46	1.05	0.50	1.07
Control Delay	93.8	52.8	44.3	91.4	13.9	93.3
Queue Delay	0.0	0.0	0.0	0.0	0.0	0.0
Total Delay	93.8	52.8	44.3	91.4	13.9	93.3
Queue Length 50th (ft)	147	326	109	-355	19	-271
Queue Length 95th (ft)	#271	347	163	#482	82	#349
Internal Link Dist (ft)		1877		667		202
Turn Bay Length (ft)	200		300		200	
Base Capacity (vph)	209	949	357	759	386	579
Starvation Cap Reductn	0	0	0	0	0	0
Spillback Cap Reductn	0	0	0	0	0	0
Storage Cap Reductn	0	0	0	0	0	0
Reduced v/c Ratio	0.91	0.90	0.46	1.05	0.50	1.07

Queues

26: Commonwealth Ave & Campus Driveway

6/3/2008



HCM Signalized Intersection Capacity Analysis

26: Commonwealth Ave & Campus Driveway

6/3/2008



Movement	SBR
Lane Configurations	
Ideal Flow (vphpl)	1900
Lane Width	12
Total Lost time (s)	
Lane Util. Factor	
Prot	
Flt Protected	
Satd. Flow (prot)	
Flt Permitted	
Satd. Flow (perm)	
Volume (vph)	117
Peak Hour Factor	1.25

Queues

2: Commonwealth Ave & Lake Street

6/3/2008

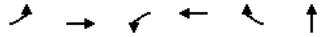

Lane Group	EBL	EBT	WBL	WBT	WBR	NBT
Lane Group Flow (vph)	290	1020	152	622	120	419
v/c Ratio	1.03	0.83	0.53	1.02	0.35	1.01
Control Delay	101.2	29.8	40.6	78.1	9.4	77.8
Queue Delay	0.0	0.0	0.0	0.0	0.0	0.0
Total Delay	101.2	29.8	40.6	78.1	9.4	77.8
Queue Length 50th (ft)	~181	259	79	~202	0	~120
Queue Length 95th (ft)	#337	324	134	#309	39	#172
Internal Link Dist (ft)		1877		667		286
Turn Bay Length (ft)	200		300		200	
Base Capacity (vph)	281	1265	285	612	342	415
Starvation Cap Reductn	0	0	0	0	0	0
Spillback Cap Reductn	0	0	0	0	0	0
Storage Cap Reductn	0	0	0	0	0	0
Reduced v/c Ratio	1.03	0.81	0.53	1.02	0.35	1.01

Intersection Summary

~ Volume exceeds capacity, queue is theoretically infinite.
Queue shown is maximum after two cycles.

95th percentile volume exceeds capacity, queue may be longer.
Queue shown is maximum after two cycles.



Queues

26: Commonwealth Ave & Campus Driveway

6/3/2008



Lane Group	EBL	EBT	WBL	WBT	NBT	SBT
Lane Group Flow (vph)	157	825	165	926	42	76
v/c Ratio	0.69	0.52	0.48	0.40	0.18	0.34
Control Delay	37.3	13.5	14.7	6.7	21.5	18.8
Queue Delay	0.0	0.0	0.0	0.0	0.0	0.0
Total Delay	37.3	13.5	14.7	6.7	21.5	18.8
Queue Length 50th (ft)	34	78	12	43	10	14
Queue Length 95th (ft)	#108	242	#124	224	42	56
Internal Link Dist (ft)		667		961	381	372
Turn Bay Length (ft)	75		75			
Base Capacity (vph)	228	1597	347	2328	418	393
Starvation Cap Reductn	0	0	0	0	0	0
Spillback Cap Reductn	0	0	0	0	0	0
Storage Cap Reductn	0	0	0	0	0	0
Reduced v/c Ratio	0.69	0.52	0.48	0.40	0.10	0.19

Intersection Summary

95th percentile volume exceeds capacity, queue may be longer.
Queue shown is maximum after two cycles.

HCM Signalized Intersection Capacity Analysis

26: Commonwealth Ave & Campus Driveway

6/3/2008

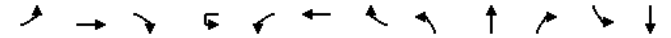

Movement	EBL	EBT	EBR	WBU	WBL	WBT	WBR	NBL	NBT	NBR	SBL	SBT
Lane Configurations	↔	↕	↔	↔	↕	↕	↔	↔	↕	↕	↔	↔
Ideal Flow (vphpl)	1900	1900	1900	1900	1900	1900	1900	1900	1900	1900	1900	1900
Lane Width	10	12	12	10	10	12	12	12	12	12	12	12
Total Lost time (s)	4.0	4.0			4.0	4.0			4.0	4.0		4.0
Lane Util. Factor	1.00	0.95			1.00	0.95			1.00	0.95		1.00
Frt	1.00	0.98			1.00	0.98			0.98	0.98		0.96
Flt Protected	0.95	1.00			0.95	1.00			0.99	0.99		1.00
Satd. Flow (prot)	1516	3168			1486	3022			1640	1477		1477
Flt Permitted	0.31	1.00			0.27	1.00			0.97	0.97		0.96
Satd. Flow (perm)	492	3168			415	3022			1600	1426		1426
Volume (vph)	96	626	112	1	151	800	57	5	29	5	6	40
Peak-hour factor, PHF	0.61	0.89	0.92	0.92	0.92	0.96	0.61	0.92	0.92	0.92	0.88	0.88
Adj. Flow (vph)	157	703	122	1	164	833	93	5	32	5	7	45
RTOR Reduction (vph)	0	14	0	0	0	6	0	0	5	0	0	22
Lane Group Flow (vph)	157	811	0	0	165	920	0	0	37	0	0	54
Heavy Vehicles (%)	0%	0%	2%	2%	2%	5%	14%	2%	2%	2%	0%	2%
Turn Type	Perm			pm+pt	pm+pt		Perm			Perm		Perm
Protected Phases		2		1	1	2 1			3			3
Permitted Phases	2			1 2	1 2			3			3	
Actuated Green, G (s)	24.4	24.4			31.7	35.7			4.8			4.8
Effective Green, g (s)	25.4	25.4			32.7	36.7			4.8			4.8
Actuated g/C Ratio	0.46	0.46			0.59	0.66			0.09			0.09
Clearance Time (s)	5.0	5.0			4.0				4.0			4.0
Vehicle Extension (s)	3.0	3.0			3.0				3.0			3.0
Lane Grp Cap (vph)	224	1445			384	1991			138			123
v/s Ratio Prot		0.26			0.06	c0.30						
v/s Ratio Perm	c0.32				0.20				0.02			c0.04
v/c Ratio	0.70	0.56			0.43	0.46			0.27			0.44
Uniform Delay, d1	12.1	11.1			5.8	4.7			23.8			24.2
Progression Factor	1.00	1.00			1.00	1.00			1.00			1.00
Incremental Delay, d2	9.5	0.5			0.8	0.2			1.1			2.5
Delay (s)	21.6	11.6			6.5	4.8			24.9			26.7
Level of Service	C	B			A	A			C			C

HCM Signalized Intersection Capacity Analysis

26: Commonwealth Ave & Campus Driveway

6/3/2008



Movement	SBR
Lane Configurations	
Ideal Flow (vphpl)	1900
Lane Width	12
Total Lost time (s)	
Lane Util. Factor	
Frt	
Flt Protected	

Queues

2: Commonwealth Ave & Lake Street

6/3/2008



Lane Group	EBL	EBT	WBL	WBT	WBR	NBT
Lane Group Flow (vph)	190	858	163	798	192	621
v/c Ratio	0.91	0.90	0.46	1.05	0.50	1.07
Control Delay	94.0	53.8	44.4	91.6	13.9	93.5
Queue Delay	0.0	0.0	0.0	0.0	0.0	0.0
Total Delay	94.0	53.8	44.4	91.6	13.9	93.5
Queue Length 50th (ft)	147	333	109	~355	19	~271
Queue Length 95th (ft)	#271	354	163	#482	82	#349
Internal Link Dist (ft)		1877		667		202
Turn Bay Length (ft)	200		300		200	
Base Capacity (vph)	209	951	356	759	386	579
Starvation Cap Reductn	0	0	0	0	0	0
Spillback Cap Reductn	0	0	0	0	0	0
Storage Cap Reductn	0	0	0	0	0	0
Reduced v/c Ratio	0.91	0.90	0.46	1.05	0.50	1.07

Intersection Summary

~ Volume exceeds capacity, queue is theoretically infinite.
Queue shown is maximum after two cycles.

95th percentile volume exceeds capacity, queue may be longer.
Queue shown is maximum after two cycles.

HCM Signalized Intersection Capacity Analysis

2: Commonwealth Ave & Lake Street/VHB, Inc.



Frpb, ped/bikes	1.00	1.00	1.00	1.00	0.78	1.00						
Frt	1.00	0.99	1.00	1.00	0.85	0.96						
Satd. Flow (prot)	1570	3151	1525	3249	1125	1511						
Satd. Flow (perm)	1570	3151	1525	3249	1125	1511						
Volume (vph)	165	630	58	135	726	167	144	256	109	0	0	0
Peak-hour factor, PHF	0.87	0.80	0.83	0.83	0.91	0.87	0.84	0.84	0.75	0.25	0.25	0.25

RTOR Reduction (vph)	0	6	0	0	0	123	0	24	0	0	0	0
Lane Group Flow (vph)	190	852	0	163	798	69	0	597	0	0	0	0
Confl. Peds. (#/hr)								54				
Heavy Vehicles (%)	0%	2%	0%	3%	0%	1%	1%	0%	1%	0%	0%	0%
Turn Type	Prot			Split		Perm		Split				
Protected Phases	1	1 2		3	3			4	4			
Permitted Phases						3						
Actuated Green, G (s)	16.0	35.9		28.0	28.0	28.0		44.0				
Effective Green, g (s)	16.0	35.9		28.0	28.0	28.0		44.0				
Actuated g/C Ratio	0.13	0.30		0.23	0.23	0.23		0.37				
Clearance Time (s)	4.0			4.0	4.0	4.0		4.0				
Vehicle Extension (s)	3.0			3.0	3.0	3.0		3.0				
Lane Grp Cap (vph)	210	943		356	759	263		554				
v/s Ratio Prot	0.12	c0.27		0.11	c0.25			c0.39				
v/s Ratio Perm						0.06						
v/c Ratio	0.90	0.90		0.46	1.05	0.26		1.08				
Uniform Delay, d1	51.2	40.3		39.4	45.9	37.5		38.0				
Progression Factor	1.00	1.00		1.00	1.00	1.00		1.00				
Incremental Delay, d2	41.4	11.8		0.9	47.0	0.5		60.8				
Delay (s)	92.6	52.2		40.4	92.9	38.0		98.7				
Level of Service	F	D		D	F	D		F				
Approach Delay (s)		59.5			76.4			98.7				0.0
Approach LOS		E			E			F				A

Intersection Summary

HCM Average Control Delay	75.0	HCM Level of Service	E
HCM Volume to Capacity ratio	1.01		
Actuated Cycle Length (s)	119.9	Sum of lost time (s)	12.0
Intersection Capacity Utilization	73.6%	ICU Level of Service	D
Analysis Period (min)	15		

c Critical Lane Group

Queues

26: Commonwealth Ave & Campus Driveway

6/3/2008



Lane Group	EBL	EBT	WBL	WBT	NBT	SBT
Lane Group Flow (vph)	65	835	134	1022	31	225
v/c Ratio	0.42	0.42	0.59	0.52	0.10	0.64
Control Delay	23.4	9.0	27.5	10.2	20.3	21.5
Queue Delay	0.0	0.0	0.0	0.0	0.0	0.0
Total Delay	23.4	9.0	27.5	10.2	20.3	21.5
Queue Length 50th (ft)	9	57	21	78	7	48
Queue Length 95th (ft)	#64	191	#164	286	34	#151
Internal Link Dist (ft)		667		961	528	372
Turn Bay Length (ft)	75		75			
Base Capacity (vph)	156	1971	226	1969	403	428
Starvation Cap Reductn	0	0	0	0	0	0
Spillback Cap Reductn	0	0	0	0	0	0
Storage Cap Reductn	0	0	0	0	0	0
Reduced v/c Ratio	0.42	0.42	0.59	0.52	0.08	0.53

Intersection Summary

95th percentile volume exceeds capacity, queue may be longer.
Queue shown is maximum after two cycles.

HCM Signalized Intersection Capacity Analysis

26: Commonwealth Ave & Campus Driveway

6/3/2008

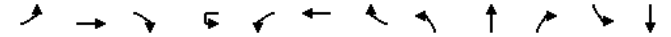

Movement	EBL	EBT	EBR	WBU	WBL	WBT	WBR	NBL	NBT	NBR	SBL	SBT
Lane Configurations	↔	↔	↔	↔	↔	↔	↔	↔	↔	↔	↔	↔
Ideal Flow (vphpl)	1900	1900	1900	1900	1900	1900	1900	1900	1900	1900	1900	1900
Lane Width	10	12	12	10	10	12	12	12	12	12	12	12
Total Lost time (s)	4.0	4.0			4.0	4.0			4.0	4.0		4.0
Lane Util. Factor	1.00	0.95			1.00	0.95			1.00	0.95		1.00
Frt	1.00	0.99			1.00	0.99			0.99	0.99		0.93
Flt Protected	0.95	1.00			0.95	1.00			0.99	0.99		0.99
Satd. Flow (prot)	1516	3198			1486	3201			1641	1571		1571
Flt Permitted	0.22	1.00			0.29	1.00			0.95	0.95		0.96
Satd. Flow (perm)	355	3198			459	3201			1579	1519		1519
Volume (vph)	49	629	71	12	111	916	28	5	21	3	25	76
Peak-hour factor, PHF	0.75	0.83	0.92	0.92	0.92	0.93	0.75	0.92	0.92	0.92	0.92	0.92
Adj. Flow (vph)	65	758	77	13	121	985	37	5	23	3	27	83
RTOR Reduction (vph)	0	7	0	0	0	3	0	0	2	0	0	48
Lane Group Flow (vph)	65	828	0	0	134	1019	0	0	29	0	0	177
Heavy Vehicles (%)	0%	0%	2%	2%	2%	1%	0%	2%	2%	2%	0%	2%
Turn Type	Perm		Perm	Perm			Perm		Perm		Perm	
Protected Phases		1				1			2			2
Permitted Phases	1		1	1			2				2	
Actuated Green, G (s)	36.1	36.1			36.1	36.1			11.0			11.0
Effective Green, g (s)	37.1	37.1			37.1	37.1			12.0			12.0
Actuated g/C Ratio	0.58	0.58			0.58	0.58			0.19			0.19
Clearance Time (s)	5.0	5.0			5.0	5.0			5.0			5.0
Vehicle Extension (s)	3.0	3.0			3.0	3.0			3.0			3.0
Lane Grp Cap (vph)	204	1839			264	1841			294			283
v/s Ratio Prot		0.26				c0.32						
v/s Ratio Perm	0.18				0.29				0.02			c0.12
v/c Ratio	0.32	0.45			0.51	0.55			0.10			0.63
Uniform Delay, d1	7.1	7.9			8.2	8.5			21.8			24.2
Progression Factor	1.00	1.00			1.00	1.00			1.00			1.00
Incremental Delay, d2	0.9	0.2			1.5	0.4			0.1			4.3
Delay (s)	8.0	8.0			9.8	8.9			21.9			28.4
Level of Service	A	A			A	A			C			C
Approach Delay (s)		8.0				9.0			21.9			28.4
Approach LOS		A				A			C			C

Intersection Summary

HCM Average Control Delay	10.7	HCM Level of Service	B
HCM Volume to Capacity ratio	0.57		
Actuated Cycle Length (s)	64.5	Sum of lost time (s)	15.4
Intersection Capacity Utilization	58.3%	ICU Level of Service	B
Analysis Period (min)	15		
c Critical Lane Group			

↙

Movement	SBR
Lane Configurations	
Ideal Flow (vphpl)	1900
Lane Width	12
Total Lost time (s)	
Lane Util. Factor	
Frt	
Flt Protected	

Queues

2: Commonwealth Ave & Lake Street

6/3/2008

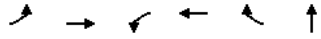

Lane Group	EBL	EBT	WBL	WBT	WBR	NBT
Lane Group Flow (vph)	290	1020	152	644	279	158
v/c Ratio	0.83	0.72	0.46	0.90	0.55	0.67
Control Delay	51.8	19.0	31.8	47.7	8.6	29.6
Queue Delay	0.0	0.0	0.0	0.0	0.0	0.0
Total Delay	51.8	19.0	31.8	47.7	8.6	29.6
Queue Length 50th (ft)	129	184	61	153	0	27
Queue Length 95th (ft)	#290	261	120	#285	51	50
Internal Link Dist (ft)		1877		667		256
Turn Bay Length (ft)	200		300		200	
Base Capacity (vph)	349	1507	332	714	504	301
Starvation Cap Reductn	0	0	0	0	0	0
Spillback Cap Reductn	0	0	0	0	0	0
Storage Cap Reductn	0	0	0	0	0	0
Reduced v/c Ratio	0.83	0.68	0.46	0.90	0.55	0.52

Intersection Summary

95th percentile volume exceeds capacity, queue may be longer.
 Queue shown is maximum after two cycles.

HCM Signalized Intersection Capacity Analysis



Queues

26: Commonwealth Ave & Campus Driveway

6/3/2008

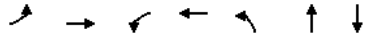

Lane Group	EBL	EBT	WBL	WBT	NBL	NBT	SBT
Lane Group Flow (vph)	133	797	165	926	108	144	76
v/c Ratio	0.78	0.52	0.67	0.48	0.36	0.30	0.43
Control Delay	59.5	19.5	31.0	13.8	24.9	21.6	31.8
Queue Delay	0.0	0.0	0.0	0.0	0.0	0.0	0.0
Total Delay	59.5	19.5	31.0	13.8	24.9	21.6	31.8
Queue Length 50th (ft)	52	132	32	119	40	48	26
Queue Length 95th (ft)	#131	322	#193	349	104	125	81
Internal Link Dist (ft)		667		961		381	372
Turn Bay Length (ft)	75		75				
Base Capacity (vph)	170	1545	246	1938	375	628	290
Starvation Cap Reductn	0	0	0	0	0	0	0
Spillback Cap Reductn	0	0	0	0	0	0	0
Storage Cap Reductn	0	0	0	0	0	0	0
Reduced v/c Ratio	0.78	0.52	0.67	0.48	0.29	0.23	0.26

Intersection Summary

95th percentile volume exceeds capacity, queue may be longer.
Queue shown is maximum after two cycles.

HCM Signalized Intersection Capacity Analysis

26: Commonwealth Ave & Campus Driveway

6/3/2008

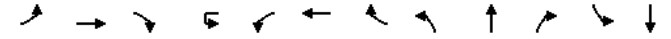

Movement	EBL	EBT	EBR	WBU	WBL	WBT	WBR	NBL	NBT	NBR	SBL	SBT
Lane Configurations	↔	↔↔			↔	↔↔		↔	↔↔			↔↔
Ideal Flow (vphpl)	1900	1900	1900	1900	1900	1900	1900	1900	1900	1900	1900	1900
Lane Width	10	12	12	10	10	12	12	12	12	12	12	12
Total Lost time (s)	4.0	4.0			4.0	4.0		4.0	4.0			4.0
Lane Util. Factor	1.00	0.95			1.00	0.95		0.95	0.95			1.00
Frt	1.00	0.98			1.00	0.98		1.00	0.96			0.96
Flt Protected	0.95	1.00			0.95	1.00		0.95	0.98			1.00
Satd. Flow (prot)	1516	3165			1486	3022		1513	1504			1477
Flt Permitted	0.31	1.00			0.26	1.00		0.72	0.92			0.96
Satd. Flow (perm)	492	3165			408	3022		1141	1417			1421
Volume (vph)	81	601	112	1	151	800	57	156	44	31	6	40

HCM Signalized Intersection Capacity Analysis

26: Commonwealth Ave & Campus Driveway

6/3/2008



Movement	SBR
Lane Configurations	
Ideal Flow (vphpl)	1900
Lane Width	12
Total Lost time (s)	
Lane Util. Factor	
Frt	
Flt Protected	

Queues

2: Commonwealth Ave & Lake Street

6/3/2008

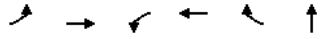

Lane Group	EBL	EBT	WBL	WBT	WBR	NBT
Lane Group Flow (vph)	190	858	163	851	364	337
v/c Ratio	0.65	0.71	0.40	0.97	0.62	0.98
Control Delay	44.9	24.9	30.2	58.1	8.4	78.6
Queue Delay	0.0	0.0	0.0	0.0	0.0	0.0
Total Delay	44.9	24.9	30.2	58.1	8.4	78.6
Queue Length 50th (ft)	97	199	73	241	0	88
Queue Length 95th (ft)	#180	223	124	#393	64	#170
Internal Link Dist (ft)		1877		667		202
Turn Bay Length (ft)	200		300		200	
Base Capacity (vph)	294	1303	410	873	588	343
Starvation Cap Reductn	0	0	0	0	0	0
Spillback Cap Reductn	0	0	0	0	0	0
Storage Cap Reductn	0	0	0	0	0	0
Reduced v/c Ratio	0.65	0.66	0.40	0.97	0.62	0.98

Intersection Summary

95th percentile volume exceeds capacity, queue may be longer.
 Queue shown is maximum after two cycles.

HCM Signalized Intersection Capacity Analysis



Queues

26: Commonwealth Ave & Campus Driveway

6/3/2008

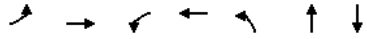

Lane Group	EBL	EBT	WBL	WBT	NBL	NBT	SBT
Lane Group Flow (vph)	45	783	134	1022	215	96	225
w/c Ratio	0.52	0.48	0.79	0.63	0.56	0.17	0.51
Control Delay	45.1	15.8	55.6	18.6	25.1	10.1	18.8
Queue Delay	0.0	0.0	0.0	0.0	0.0	0.0	0.0
Total Delay	45.1	15.8	55.6	18.6	25.1	10.1	18.8
Queue Length 50th (ft)	12	108	46	160	71	11	24
Queue Length 95th (ft)	#69	247	#216	398	171	53	71
Internal Link Dist (ft)		667		961		528	372
Turn Bay Length (ft)	75		75				
Base Capacity (vph)	87	1633	170	1633	419	680	639
Starvation Cap Reductn	0	0	0	0	0	0	0
Spillback Cap Reductn	0	0	0	0	0	0	0

HCM Signalized Intersection Capacity Analysis
26: Commonwealth Ave & Campus Driveway

6/3/2008

Movement	SBR
Lane Configurations	
Ideal Flow (vphpl)	1900
Lane Width	12
Total Lost time (s)	
Lane Util. Factor	
Fr	
Flt Protected	
Satd. Flow (prot)	
Flt Permitted	
Satd. Flow (perm)	
Volume (vph)	102
Peak-hour factor, PHF	0.89
Adj. Flow (vph)	115
RTOR Reduction (vph)	0
Lane Group Flow (vph)	0
Heavy Vehicles (%)	0%
Turn Type	
Protected Phases	
Permitted Phases	
Actuated Green, G (s)	
Effective Green, g (s)	
Actuated g/C Ratio	
Clearance Time (s)	
Vehicle Extension (s)	
Lane Grp Cap (vph)	
v/s Ratio Prot	
v/s Ratio Perm	
v/c Ratio	
Uniform Delay, d1	
Progression Factor	
Incremental Delay, d2	
Delay (s)	
Level of Service	
Approach Delay (s)	
Approach LOS	
Intersection Summary	

Boston College Parking Supply Inventory

BOSTON COLLEGE PARKING SUPPLY

Facility	Number of Spaces							
	Existing Utilization			Lost				
	Existing	Number of Vehicles Parked	Percent	# of Spaces	IMP Project	Added	Net Changes	Future
Brighton Campus								
St. Clement's Across Foster	74	58	78%	74	Grad Housing (1)	34	40	34
St. Clement's Front	27	19	70%	0		0	0	27
St. Clement's Upper	31	27	87%	0		0	0	31
St. Clement's Lower	29	26	90%	0		0	0	29
			81%					
Garage Front	23	10	43%	23	Garage (5)	500	477	500
Tennis Lower	38	0	0%	38	Athletics Center (2)	0	38	0
Tennis Middle	42	20	48%	42	Athletics Center (2)	0	42	0
Tennis Upper	42	33	79%	42	Athletics Center (2)	0	42	0
Bishop Peterson (Front)	61	31	51%	0		0	0	61
Bishop Peterson (Rear Lower)	6	6	100%	0		0	0	6
Bishop Peterson (Rear Upper)	17	7	41%	0		0	0	17
Bishop Peterson (Across from Garage)	4	4	100%	0		0	0	4
Bishop Peterson (Lake St. Side)	25	22	88%	0		0	0	25
			52%					
3 Lake Street	17	16	94%	0		0	0	17
Library Lot	163	20	12%	163	Internal Housing (7)	0	163	0
Facing Library row parallel Lake	21	8	38%	21	Internal Housing (7)	0	21	0
St. William's	31	11	35%	0		0	0	31
St. William's (Rear)	4	0	0%	4	Internal Housing (7)	0	4	0
St. William's (Rear Row Behind Bldg.)	22	9	41%	22	Internal Housing (7)	0	22	0
Chancery (Rear close to Library Lot)	36	33	92%	36	Internal Housing (7)	0	36	0
Chancery Arc	16	12	75%	0		0	0	16
Chancery (Perpendicular to Comm)	32	16	50%	14	Internal Housing (7)	0	14	18
Gymnasium Lot	22	10	45%	22	Fine Arts District (10)	0	22	0
Cardinal's Residence (along road)	26	0	0%	0		0	0	26
Cardinal's Residence Lot East	4	0	0%	0		0	0	4
Cardinal's Residence Lot West	6	0	0%	6	Fine Arts District (10)	0	6	0
			34%					
Brighton Campus Total	819	398	49%	507		534	27	846

Chestnut Hill Campus

More Hall Rear	85	72	85%	85	Housing (12)	100	15	100
More Hall arc (2 + 9 unlined)	2	4	200%	2	Housing (12)	0	2	0
					Recreation Center			
110/Walsh	25	23	92%	25	(13)	0	25	0
St. Ignatius	18	10	56%	0		0	0	18
Vanderslice	22	18	82%	0		0	0	22
Southwell	4	4	100%	0		0	0	4
66 Comm Ave	9	2	22%	0		0	0	9
Rubenstein/66	10	7	70%	0		0	0	10
Rubenstein Rear/Gabelli	7	3	43%	0		0	0	7
Rubenstein Wall	14	12	86%	0		0	0	14
Rubenstein								



Remainder Triangle and Beacon St.

75



0

0

0

75

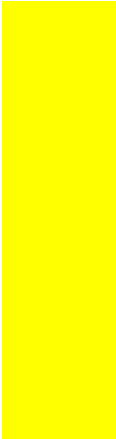

Added	Utilization	Brighton Campus Supply
	398	819
0	398	745
0	398	623
500	398	1100
34	398	1134
0	398	1080
0	398	1052
0	398	846
534	398	846

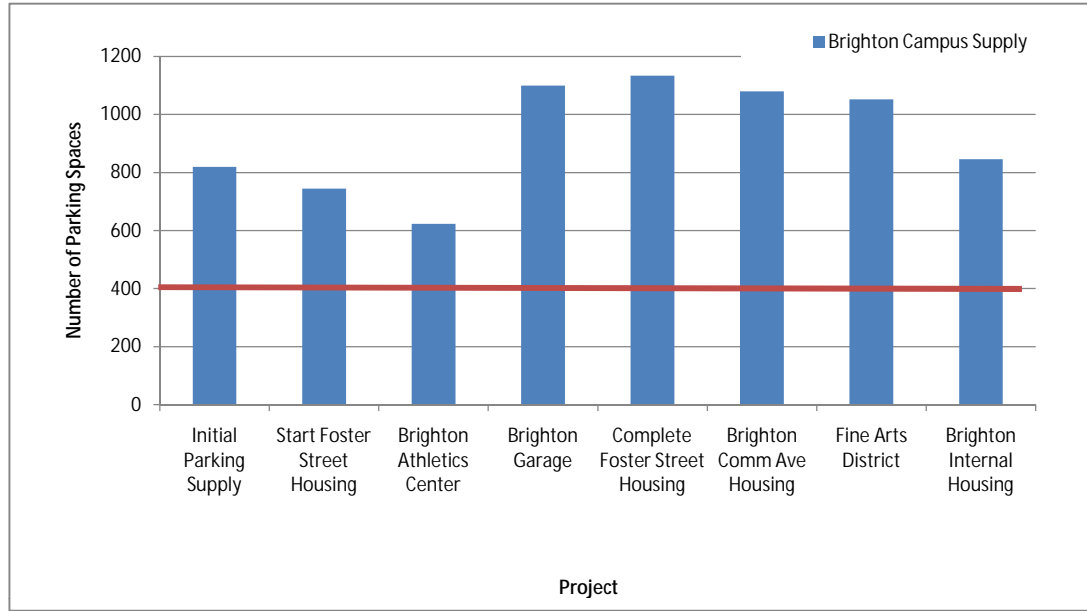

Added	Utilization	Chestnut Hill Campus Supply
	2091	3011
0	2091	2902
0	2091	2815
200	2091	3015
100	2091	3115
90	2091	3205
0	2091	3061
350	2091	3382
0	2091	3332
0	2091	3038
740	2091	3038

